



SHOCKER XLS

OWNER'S MANUAL



SP

QUICK START

WARNING

Velocity must be measured and adjusted to below 300 feet per second (91.4 meters per second) before each session of use.

01 INSTALL BATTERY



Use a 5/64-inch hex key to remove the three screws from the left side of the wrap-around grip and lift the left side open.

Attach the battery clip to a new brand-name 9-volt alkaline battery and place it in the grip frame. Carefully tuck the battery wires out of the way of the grip.

Close the grip and reinstall the grip screws.

02 BARREL

Assemble and install the included barrel. Make sure The Freak® insert is installed inside the barrel back.

Install the assembled barrel in the front of the Shocker® XLS body.

Take care not to cross-thread any barrel components during assembly or installation, as permanent damage may result.

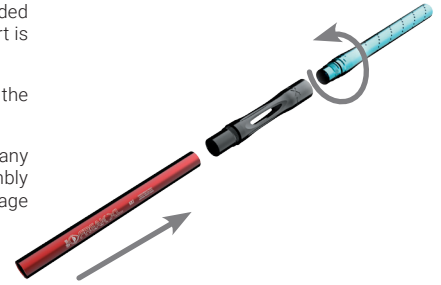

03 BARREL BLOCKER & LOADER

Install a high-performance paintball loader in the locking feedneck. In order to perform its at its best, the Shocker® XLS must be consistently fed unbroken paintballs rapidly.

Slide the included barrel blocker over the end of the Shocker® XLS barrel. Sling the blocker's cords over the back of the marker and snug them tight.

The barrel blocker is a critical piece of safety equipment and must always be used when the Shocker® XLS is handled outside of an active paintball field.

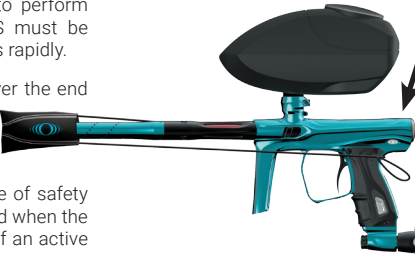

04 TURN ON AIR

Carefully screw a professionally filled paintball High Pressure Air (HPA) system into the Air Source Adapter (ASA).

Slowly turn the ASA knob clockwise to gently charge the Shocker® XLS with air.

WARNING

Turn knob slowly!
A quick pressure surge
may cause damage.

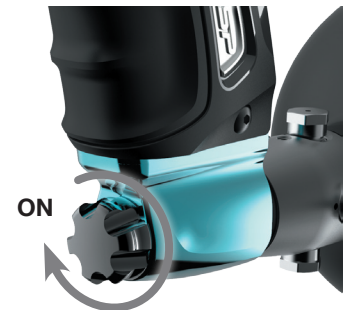

05 POWER



Turn on the Shocker® XLS by pressing and holding the power button until it glows green and the XLS data display animates.

The Shocker® XLS may be turned off by pressing and holding the power button until it goes dark.

Turning off the Shocker® XLS serves the same function as a mechanical trigger safety, but should not be relied on in place of a barrel blocker.

06 ADJUST VELOCITY



Velocity must be tested and adjusted at the start of each paintball session. Fill the loader with paintballs and turn it on. While wearing ASTM compliant paintball goggles in an area where all bystanders are protected, remove the barrel blocker and fire over a chronograph to measure the velocity. Using a 5/32-inch hex key, turn velocity up (clockwise) or down (counter-clockwise) as needed to meet the field's standard. After each adjustment take 2 or three shots to allow pressure to stabilize, then fire over a chronograph to check velocity. For safety and to avoid internal damage, never adjust the Shocker® XLS to fire at greater than 300 feet per second.

TABLE OF CONTENTS

CONTENTS

QUICK START - VELOCITY ADJUSTMENT	02
TABLE OF CONTENTS	03
DIGITAL CONTROLS	04
GASSES	05
ADJUSTMENT/TUNING	
PROGRAMMING	06
ELECTRONIC SETTINGS	07
FIRING MODES	08
TRIGGER ADJUSTMENT	09
QEV FORCE ADJUSTMENT	10
FEEDNECK ADJUSTMENT	10
ROUTINE MAINTENANCE	
BOLT / VALVE	11
VISION™ / DETENTS	12
ASA	13
ADVANCED MAINTENANCE	
REGULATOR	14
GRIP FRAME	16
BOLT CONTROL / SOLENOID VALVE / QEV	18
TROUBLESHOOTING	19
PARTS GUIDE	21
WARRANTY / TECH SUPPORT	39

XLS SPECS

OPERATING PRESSURE	145 psi
POWER SOURCE	9v Alkaline Battery
PROPELLANT	High Pressure Air
OPERATION	Electropneumatic
MODES OF FIRE	10
ANTI-CHOP SYSTEM	Break Beam Vision
BARREL THREAD	Autococker
LUBRICANT	GR33SE™

WARNING

- THE SHOCKER® XLS IS NOT A TOY.
- MISUSE OF THE SHOCKER® XLS MAY RESULT IN SERIOUS INJURY OR DEATH.
- EYE PROTECTION DESIGNED FOR PAINTBALL USE MUST BE WORN BY THE USER AND ANY PERSON WITHIN RANGE OF THE SHOCKER® XLS.
- SP RECOMMENDS THAT THE SHOCKER® XLS ONLY BE SOLD TO PERSONS 18 AND OLDER.
- THOROUGHLY READ THE SHOCKER® XLS OPERATION AND INSTRUCTION MANUAL BEFORE OPERATING.

DIGITAL CONTROLS

PLEASE READ CAREFULLY

POWER The Shocker® XLS is turned on by pressing and holding the power button for a full second, or until the power button glows green and the data display activates [See FIG 07]. As soon as the Shocker® XLS is on, it is live and ready to fire. When the Shocker® XLS is in use, the power button may illuminate in different colors, or stop glowing to indicate various conditions. The Shocker® XLS is turned off by pressing and holding the power button for approximately five seconds. Turning the Shocker® XLS off is the equivalent to using a trigger “safety” switch on a mechanical paintball marker - while an important feature, it does not replace proper use of the barrel blocker.

MODE The currently selected firing mode and its Rate of Fire Cap (ROF Cap) are shown near the top of the data display.

VISION™ The status of the Vision™ anti-chop system is shown as a paintball in the middle of the display. A hollow paintball and blinking green power button indicates that the breech is empty. A solid paintball and solidly lit green power button indicates that the breech is full and ready to fire. If a problem is detected “EYE FAULT” will be displayed and the power button will blink red. Vision™ may be manually turned on or off by a quick double-tap of the power button. It may be turned back on the same way. The power button will glow red and the display will read “EYEOFF” with an X in place of the paintball when Vision™ is off. When Vision™ is off or faulted, the Shocker® XLS will pause between shots to allow more time for the next paintball to settle in place.

BATTERY Estimated battery charge level is indicated in the lower right of the display. Accuracy may vary between battery brands, especially when using rechargeable batteries.

MAX ROF The highest rate of fire achieved during the last few seconds is shown below the middle of the display.

FIRMWARE VERSION When the game timer is off, the firmware version is shown in the lower left corner of the display. Shocker® XLS firmware updates may be needed to comply with laws restricting firing modes in different countries, changes in league modes or to change languages used in the data display.

07 RSX DATA DISPLAY

POWER BUTTON

MODE & ROF CAP

PROGRAMMING
LOCK
VISION STATUS

MAX ROF

FIRMWARE
VERSION

BATTERY
LEVEL



Firmware installation instructions and software are available at www.ShockerPaintball.com.

GAME TIMER When enabled, the game timer is displayed in the bottom left of the display. The timer starts counting down when the first shot is fired. Turning the Shocker® XLS off and back on again will reset the timer.

WARNING

Never put oil or other petroleum products in a compressed air regulator or tank—only use manufacturer specified lubricants or cleaners.

GASES

LOOSEN ASA KNOB 08



GASSING The Shocker® XLS is equipped with a bottom-line style air source adapter (ASA). Before screwing an HPA system into the ASA, make sure the ASA is turned off by loosening the ASA knob on its front [FIG 8]. Take care not to turn the ASA knob too far.

After screwing the HPA system into the ASA, air is released into the marker by tightening the ASA knob [FIG 4]. It is important to turn the knob slowly. Once air can be heard entering the marker, wait until the hissing stops before turning the ASA knob further to fully open the HPA regulator. This will protect the internal components from a sharp rise in pressure, ensuring longer life.

REMOVE HPA SYSTEM 09



WARNING
Do not to unscrew HPA tank from its regulator!

DEGASSING AND UNLOADING After use the Shocker® XLS should be unloaded and degassed. In some jurisdictions, paintball markers are legally required be unloaded and degassed before they are transported on public roads.

The ASA is turned off by rotating the ASA knob counter-clockwise (loosening). When the knob is twisted far enough to turn the ASA off, a small amount of air will vent from the ASA with a brief hissing sound. This is normal. Do not turn the knob any further.

Turning off the ASA does not completely depressurize the Shocker® XLS and may leave enough gas inside the marker to fire 2 or more shots.

In a safe area (all persons protected by paintball goggles and or netting, such as a paintball field's chronograph area) remove the loader from the Shocker® XLS.

The Shocker® XLS is designed to be powered by a high-pressure compressed air (HPA) system only. Use of carbon dioxide (CO₂) to power the Shocker® XLS is likely to cause damage to sensitive internal seals and will result in a voided warranty. HPA systems with a 3000psi or 4500psi capacity can be utilized on the Shocker® XLS. HPA systems with output pressures between 450psi and 850psi can be used with the Shocker® XLS. An output pressure of 800-850psi is recommended for maximum consistency at high rates of fire (15bps+). HPA systems are shipped empty, and must only be filled by properly trained personnel.

Tip the Shocker® XLS to dump any paintballs from the breech. Remove the barrel blocker. Turn the Shocker® XLS on, turn off the Vision™ anti-chop system by pressing the power button for a full second, then dry-fire in a safe direction until the bolt no longer cycles with each trigger pull. Turn the Shocker® XLS off, put the barrel blocker back on and unscrew the HPA system from the grip ASA.

Take care to ensure that the HPA tank does not unscrew from its regulator when unscrewing the regulator from the ASA.

PROGRAMMING

PLEASE READ CAREFULLY

PROGRAMMING LOCK A padlock icon in the display indicates the status of the programming lock. When the Shocker® XLS is locked, velocity, rate of fire and firing modes cannot be changed without the use of tools, as required by paintball tournament and field rules. The Shocker® XLS may be easily locked for use or unlocked for maintenance and tuning by opening the left side of the grip as when installing a battery [FIG. 1]. Turn the Shocker® XLS on and press the programming lock button on the XLS Circuit Board [FIG. 10] to change the programming lock status. Turn the Shocker® XLS off and secure the grip with its screws when finished.

SETTINGS MENU Electronic adjustments to the Shocker® XLS are made through the settings menu when the marker is unlocked, unloaded and de-gassed. To access the settings menu, turn the Shocker® XLS on while holding the trigger down. Release the trigger when the Shocker® XLS has booted into its settings menu [FIG. 11].

The settings menu is indicated by the text “MAIN MENU” near the top of the XLS data display.

Separate settings are recorded for each firing mode. For example, the Rate of Fire Cap (ROFCap) in a league requiring Capped Semi-Automatic mode may be different from the ROFCap in a league using PSP mode. When the Firing Mode of the Shocker® XLS is changed, the ROFCap changes with it. Only the settings used with the currently selected firing mode are displayed in the Settings Menu.

10 PROGRAMMING LOCK



11 MENU

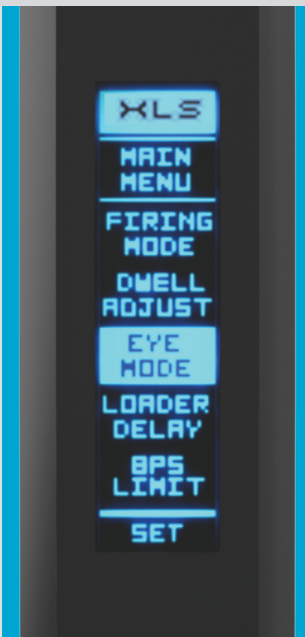

In the settings menu, tapping the trigger scrolls through the available settings. To scroll through the available settings, holding the trigger down for two seconds selects the highlighted setting for adjustment. Tap the trigger to scroll through the values available for the setting, then hold the trigger down for a second to select. After adjusting settings, press and hold the power button to save the changes and turn off the Shocker® XLS.

Because of the wide variety of adjustments that can be made in the settings menu while seeking maximum performance, it is possible to de-tune the Shocker® XLS into a state of unreliable operation. It is easy to recover from this condition with a factory reset. Enter the settings menu and continue to hold the trigger back for five additional seconds to reset the Shocker® XLS to its factory default settings for most reliable operation. The screen will flash four times to indicate that a factory reset has been performed.

FIRING MODE The Shocker® XLS is capable of operating in various firing modes for compliance with different tournament rules and playing styles. Due to import restrictions, not all firing modes are available in every country where the Shocker® XLS is sold. For a list of all available firing modes see the Firing Modes section of this manual.

DWELL ADJUST This setting adjusts the length of time the solenoid valve is activated to fire each shot.

CAUTION – Dwell changes can affect velocity. Always measure and re-adjust velocity (see Quick Start of this manual) after changing the Dwell setting.

EYE MODE This setting selects the Vision™ anti-chop method to be used. There are two options available. Block only allows the Shocker® XLS to fire if there is a paintball blocking the Vision™ beam. Forced mode also does not fire if the breech is empty when the trigger is pulled, but if the trigger is held down for a full second, the marker will fire regardless of Vision™ beam status.

LOADER DELAY This delay is the amount of time the Shocker® XLS waits after detecting a paintball before it fires. Loader Delay allows time for the paintball to settle all the way into the breech before the bolt closes.

BPS LIMIT This setting is used in combination with BPS Fine to limit how many times per second the Shocker® XLS may fire by setting the Rate Of Fire Cap (ROFCap) in whole Balls Per Second(BPS).

BPS FINE This setting adjusts the ROFCap in 0.1 bps increments. A BPS LIMIT of 12 with a BPS FINE setting of 5 creates a ROFCap of 12.5 balls per second. For some firing modes such as Automatic, the ROFCap defines how many shots per second the Shocker® XLS will fire. For others, such as Capped Semi-automatic where the rate of fire is determined by how fast the player pulls the trigger, the ROFCap defines the limit of how fast the Shocker® XLS will be allowed to fire.

BYPASS BPS When the Vision™ anti-chop system has detected a fault or is turned off, the Bypass BPS setting will be used as the

ROFCap instead of the BPS Limit and BPS Fine settings. In this condition, the slower maximum rate of fire can reduce the risk of chopping a paintball that has not had enough time to fully seat in the breech before the Shocker® XLS fires.

BURST COUNT The number of shots fired per trigger pull in BURST Firing Mode.

RAMP START How quickly RAMP mode increases the rate of fire compared to the rate of trigger pulls.

RAMP PRCNT • RAMP PERCENTAGE – How much faster the RAMP mode should make the rate of fire compared to the rate of trigger pulls when it is fully engaged.

TRGGR DBNCE • TRIGGER DEBOUNCE – Adjusts the length of time the XLS processor must see a signal from the trigger switch to determine that the trigger has been pulled. Setting Trigger Debounce too low may result in more than one shot per player's pull of the trigger in semi-automatic modes.

MECH DBNCE • MECHANICAL DEBOUNCE – Adjusts how the XLS processor filters out trigger signals caused by mechanical vibration. Setting Mechanical Debounce too low may result in more than one shot per player's pull of the trigger in semi-automatic modes.

FSDO ADJUST • FIRST SHOT DROP-OFF ADJUST – When the Shocker® XLS sits for several seconds between shots, the bolt may require a higher dwell time to break friction and fire at the full velocity. FSDO Adjust sets this increased dwell in milliseconds.

FSDO TIMER • FIRST SHOT DROP-OFF TIMER – The amount of time in seconds the Shocker® XLS must sit idle before a shot is considered the “first shot” in need of higher dwell time to break friction.

AUTO OFF The amount of time in minutes that the Shocker® XLS must be unused before it turns itself off to conserve battery charge.

TIMER ENABLE Turns the game timer on or off.

TIMER ADJUST Sets the length of the game timer in minutes.

FIRING MODES

PLEASE READ CAREFULLY

The Shocker® XLS is equipped with 11 firing modes, selectable from the Firing Mode setting in the Settings Menu.

SEMI • SEMI-AUTOMATIC – This mode provides one shot per pull of the trigger. Note that low debounce settings may generate additional shots. Proper de-bounce adjustment is required to provide a true semi-automatic mode. This is the only mode not limited by the ROFCap.

C SEMI • CAPPED SEMI-AUTOMATIC – This mode operates the same as semi-automatic, but will not fire faster than the ROFCap.

NXL • NATIONAL X-BALL LEAGUE – This is an enhanced mode to comply with NXL rules. This mode begins by firing one shot per trigger pull. When the trigger is pulled at a rate faster than 5 times per second, the Shocker XLS will fire additional shots with each trigger pull, up to the ROFCap rate.

PSP • PAINTBALL SPORTS PROMOTIONS – Built to comply with PSP rules this mode fires one shot per trigger pull until three trigger pulls are made quickly in a row. The Shocker® XLS then begins firing more than one shot per trigger pull up to the ROFCap rate, to increase the effective rate of fire. If one second goes by without a trigger pull or release, the marker reverts to firing one shot per trigger pull.

MILL • MILLENNIUM SERIES – Designed for use in the Millennium Series, this mode fires one shot per trigger pull by default. When the trigger is pulled at a rate faster than 5 times per second, additional shots are fired with each trigger pull, up to the ROFCap rate.

RESP • RESPONSE – Electronically simulating a physical trigger modification from the 1990s, this mode effectively doubles the player's rate of fire (up to the ROFCap) by firing when the trigger is pulled and then again when it is released.

BURST • MULTI-SHOT BURST

This mode fires a burst of shots each time the trigger is pulled. Whether the trigger is held down or released before the burst is

complete, the Shocker® XLS will fire the number of shots specified by the Burst Count setting at the ROFCap rate.

AUTO • SAFETY FULL AUTOMATIC – In this mode, the Shocker® XLS will fire repeatedly at the ROFCap rate for as long as the trigger is held down (full-auto), on the second of two rapid trigger pulls. The first single shot and trigger pull used to initiate full-automatic operation serves as a safety feature to prevent accidental full-automatic firing if the Shocker® XLS is set down against an object which presses on its trigger.

SELECT • SELECT FIRE – This mode is actually three modes in one. Designed for use in scenario games and big games where full-automatic operation is allowed, Select Fire allows the player to switch between SEMI, PSP, and NXL while the programming lock is engaged, to comply with the event's velocity locking rules. In Select Fire mode, the player may switch between the three available firing modes by quickly tapping the power button. When Select Fire is in use, the data display reads SELECT SEMI, SELECT PSP, or SELECT NXL, depending on which mode is in use.

RAMP • RAMPING – This mode begins firing one shot per trigger pull, and then fires progressively at a pace faster than the trigger pull up to the ROFCap, as the rate of trigger pulls is increased.

12 FIRING MODES



ADJUSTMENT POINTS 13

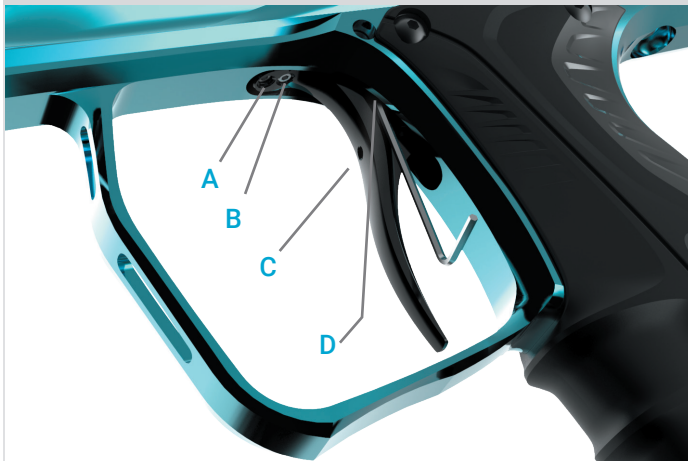

WARNING

Turning the trigger activation point screw in too far may cause **PERMANENT TRIGGER SWITCH DAMAGE** and create a safety hazard. After trigger adjustments have been made, the trigger should stop with the solid feel of the post-travel screw making contact with the grip frame. If the trigger activation point screw is adjusted too far in, the trigger will come to a soft stop against the XLS trigger switch, which may then become damaged by hard or rapid trigger pulls.

The Shocker® XLS has four main points of trigger adjustment which may be set with a 1/16" allen key. This provides the ability to fine-tune the perfect trigger for any style of play. Every paintball player is unique with individual tastes. The Shocker® XLS trigger is easy to tailor for an ideal fit. Adjustment should only be performed with the marker unloaded and degassed.

MAGNETIC TENSION The primary force providing trigger resistance and returning the trigger to its forward position after a trigger pull is supplied by a compact rare-earth magnet in the Shocker® XLS's air manifold.

The magnet pulls against the magnetic tension screw located at the front of the trigger [FIG 13A]. This arrangement provides trigger resistance that is strongest when the trigger is forward in its rest position and diminishes through the trigger stroke towards the rear.

Adjusting the magnetic tension screw outward (counter-clockwise) increases the distance between the magnet and adjustment screw, and results in a lighter trigger pull. Turning the screw in provides a stronger magnetic pull allowing for a more responsive trigger return. The strongest trigger resistance is achieved when the magnetic tension screw is able to make contact with the trigger return magnet when the trigger is at rest.

PRE-TRAVEL The length of the trigger pull is determined by where the trigger stops in its forward position and how far back it can be pulled. The forward limit of the trigger swing is adjusted with the pre-travel adjustment screw located at the top front of the trigger, just behind the magnetic tension screw [FIG 13B]. Turning the pre-travel adjustment screw inward pushes against the air manifold forcing the trigger back, shortening the trigger pull. Turning the screw outward has the opposite effect.

POST-TRAVEL The post-travel screw limits how far back the trigger can be pulled, by impacting against the air manifold at the rear of the trigger swing. This screw is placed at an angle which allows it to be adjusted from the left side of the Shocker® XLS [FIG 13D]. Turning the post-travel screw inward extends it further out the top of the trigger, shortening the overall trigger pull. Turning the screw out allows the trigger to be pulled further back. It is important that the post-travel and activation point screws be set so that the post-travel screw makes solid contact when the trigger is pulled all the way back.

POST-TRAVEL This screw [FIG 13C] determines how far the trigger must be pulled before the trigger switch is activated. Turning it inward fires the Shocker® XLS earlier in the trigger pull, while turning it outward requires a further pull before firing.

It is a simple matter to adjust the Shocker® XLS to the shortest, lightest trigger pull possible, but that will often not provide optimum performance. A slightly longer pull with enough resistance that the trigger resets more positively allows the trigger to be walked to higher rates of fire.

QEV ADJUSTMENT Bolt closing force has a significant impact on how a paintball marker fires, both in terms of the marker's ability to handle brittle paintballs and the amount of recoil felt with each shot. The quick exhaust valve (QEV) in the Shocker® XLS air manifold includes an adjustment screw that can be used to restrict air flow from in front of the bolt's sail, providing a wide adjustment range over bolt closing force.

The bolt force adjustment screw [FIG.. 14] is set with a 1/16" hex wrench through a small hole in the top of the grip frame, just behind the front of the trigger guard. As with trigger adjustment, a ball-end hex wrench will allow easier access to this adjustment screw. When the screw is backed out all the way out (counter-clockwise) the exhaust air-flow path is wide open, providing minimal air resistance against the closing bolt for the fastest possible firing rates.

Turning the bolt-force adjustment screw in (clockwise) creates a smaller path for air to escape. As a result, a pocket of air acts as a cushion to balance against the air pushing the bolt to its forward position. With a decreased net force pushing it forward, the bolt closes more slowly.

A fast moving bolt has the obvious advantage of being able to fire at a faster rate, while a slower bolt reduces recoil for improved accuracy and reduced breakage of thin-shelled brittle tournament grade paintballs.

FEEDNECK ADJUSTMENT Although the size of loader feednecks is standardized within the paintball industry, there are typically small variances in diameter between manufacturers, and even between different loaders of the same model type.

The Shocker® RSX is equipped with an adjustable feedneck ensuring that it can securely grip loaders with a wide range of feedneck sizes. The feedneck's clamping mechanism is best adjusted with the clamp lever open.

Simply turning the clamp lever will close down or open up the clamp mechanism. Finer adjustments can be made by twisting the thumbwheel [Fig 15]. Test fit after adjustment. The feedneck should have a firm grip on the loader, but the lever should not be difficult to close or open.

14 BOLT FORCE ADJUSTMENT SCREW

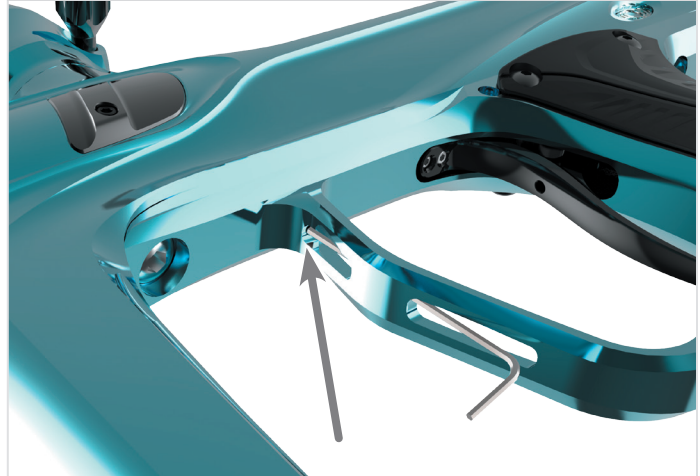

15 FEEDNECK CLAMP ADJUSTER SCREW

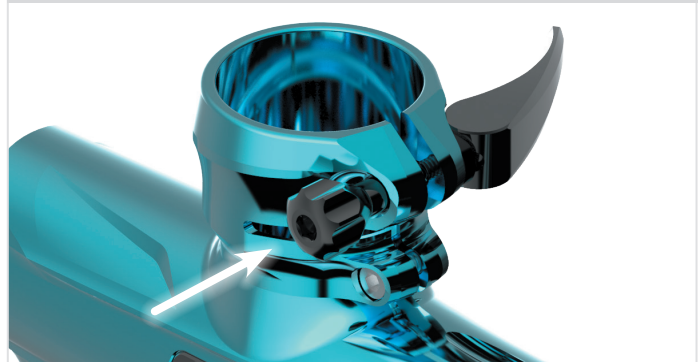

PLEASE READ CAREFULLY

BOLT CLEANING

RELEASE LATCH 16

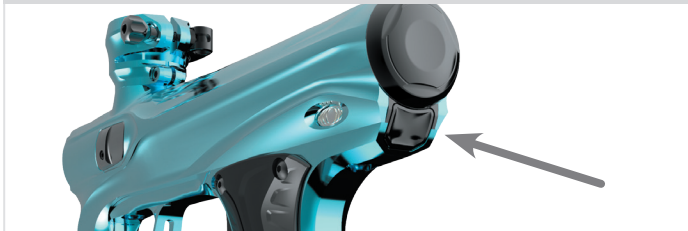

The Shocker® XLS utilizes a spool valve design which combines its bolt with its main exhaust valve for a system that uses few parts for efficient performance with few possible failure points. Occasionally the bolt system may need to be cleaned. It also should be lubricated after each day's use as regular maintenance. No tools are required for this procedure.

BOLT ASSEMBLY REMOVAL 17



REMOVAL With the Shocker® XLS unloaded and degassed, pressing on the bolt release latch [FIG. 16] will cause the end-cap to pop out. In its extended position, the end-cap serves as a handle to pull the entire bolt assembly from the marker body as a single unit [FIG. 17].

INSTALLING BOLT ASSEMBLY 18

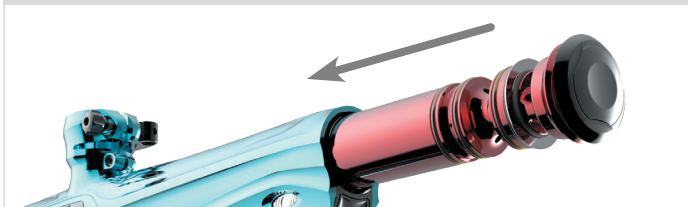

CLEANING Unscrewing the firing can [FIG. 19A] from the main chamber [FIG. 19D] provides access to the bolt [FIG. 19B] for cleaning and inspection. All parts of the bolt assembly should be wiped free from paint or other debris with a soft cloth. All o-rings should be inspected for tears, flat spots or other visible damage and replaced if necessary. Before re-assembly all o-rings should be greased lightly with GR33SE™. The outer surface of the bolt's mid-section should also receive a very light coat of GR33SE™. Oil or other lubricants may cause damage and should not be used.

REASSEMBLY Care should be taken when re-assembling the valve assembly. The greased parts should not be set on a dirty surface where they will pick up dust or sand particles that can prevent o-rings from obtaining a good seal. With the bolt placed in the chamber guide [FIG. 19C] and the chamber guide seated in the main chamber, the firing can should be screwed gently into place. The complete bolt assembly can then be pushed into the body of the Shocker® XLS until the latch mechanism makes an audible click, locking everything in place with the rear cap flush against the body.

BOLT ASSEMBLY COMPONENTS 19

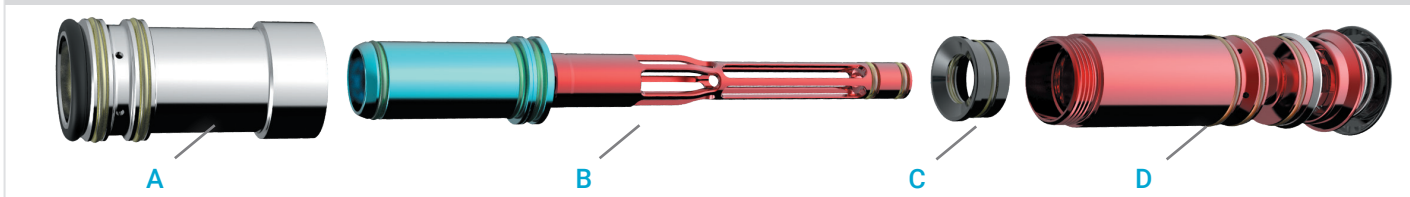

DETENTS The ball detents in the Shocker® XLS prevent double-feeding and subsequent chopping of paintballs by preventing them from rolling forward until they are pushed into the barrel by the bolt. Optional low-profile detents [FIG... 21D] may be installed for better reliability with extremely large or out of round paint.

Each detent extends into the breech under spring pressure until it is pushed out of the way by the paintball and bolt during the firing cycle. If a paintball is broken in the marker, or dirt is able to get in through the feedneck, the ball detents can become stuck, either not extending into the breech to do their job, or stuck in the breech, blocking proper bolt movement. In either case, cleaning the detent system is a simple process.

DETENT CLEANING With the marker unloaded and degassed, a 1/16-inch hex key can be used to unscrew the Vision™ cover screws [FIG. 20]. Finger pressure against the detent from inside the breech is enough to unseat the Vision™ covers so they can be removed from either side of the Shocker® XLS. This will allow access to the detents [FIG. 21A] for inspection and cleaning. Cotton or foam swabs are ideal for cleaning the small nooks in and around the detent. In severe cases, the detent may need to be removed from the Vision™ cover by pulling the hooked top of the detent hinge pin with an o-ring pick [FIG. 21B] while taking care not to lose the detent or spring [FIG. 21C] when they are released and lifted away. Cleaning the detent assembly is all that is needed for routine maintenance. Do not lubricate the detent or the Vision™ cover screw o-ring. The o-ring must provide friction to lock the screw in place, and grease will gum up the detent. Care should be taken not to cross-thread or over-tighten the Vision™ cover screw as this may cause permanent damage to the Shocker® XLS body.

VISION™ SENSORS The Vision™ sensors, or “eyes” consist of an infra-red LED on one side of the breech and a sensor on the other. When a paintball blocks the beam of invisible infrared light, the XLS processor determines that a paintball has moved into place. Paint or shell from a broken paintball, dirt from the field or other debris can block the breech openings used by the Vision™ system resulting in a Vision fault.

VISION™ CLEANING The Vision™ sensors and their openings in the body are easily cleaned with a cotton or foam swab when

20 VISION™ COVER SCREW

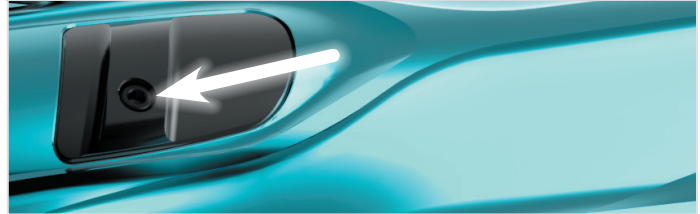

21 DETENT REMOVAL

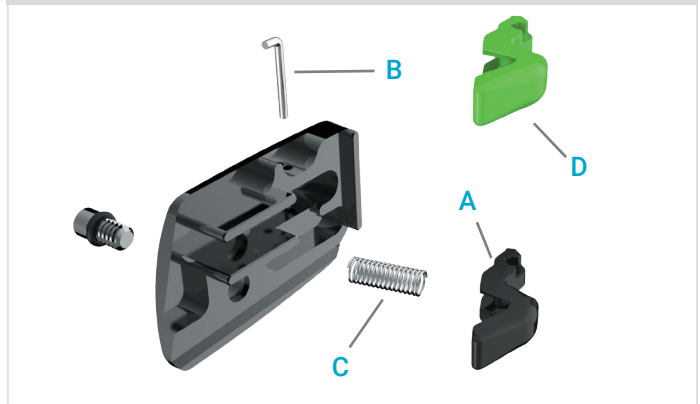

22 VISION™ SENSOR

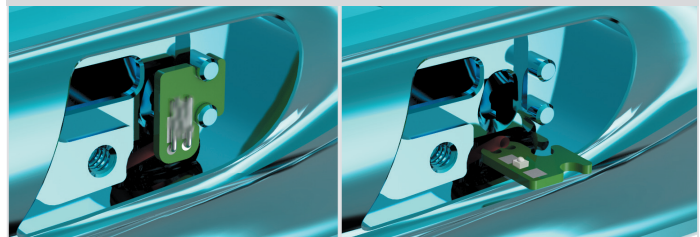

the Vision™ covers are removed. The sensors must be properly seated between their pins [FIG. 22] before the Vision™ covers are reinstalled.

ASA KNOB 23



ASA KNOB The ASA Knob may occasionally need to be removed for cleaning or lubrication, especially if the Shocker® XLS has taken a hard dive into a muddy or sandy bunker, driving debris into the ASA around its knob. As with all maintenance, this must be done only with the Shocker™ XLS unloaded and degassed.

Unscrew the ASA Knob, as if turning the air supply off, but continue unscrewing until the knob comes free of the ASA.

The screw threads of the ASA may be lubricated with GR33SE™, but only place an extremely thin layer of GREASE™ on the pin. Excess grease can clog the ASA's filter. Take care when reinstalling the ASA knob, to be sure it is not cross-threaded.

ASA REMOVAL 24



REMOVAL Further removal or disassembly should only be performed on an as-needed basis, not as a part of routine maintenance. After removing the ASA Knob, use a 5/32-inch hex key through the two holes in the bottom of the ASA to unscrew the ASA mount screws. Unscrew the front screw first, followed by the rear screw. They must be unscrewed in order, as the back screw does not have room to unscrew while the ASA is in place against the grip frame. These screws will not come out the bottom of the ASA, the screw heads remain trapped in a slot in the top of the ASA body. Once both screws are completely out of the grip frame, the ASA may be lifted away from the grip frame. The ASA screws may be removed, if needed by sliding them one at a time to the opening in the center of the top slot in the ASA.

ASA DISASSEMBLY 25

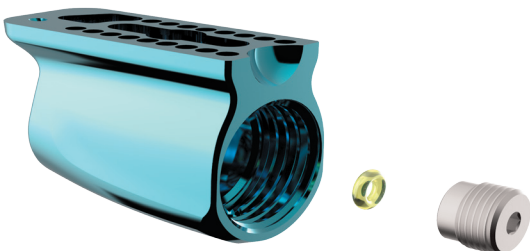

The ASA filter o-ring should remain in their hole in the front left corner of the bottom of the grip frame. They may be removed and inspected, replacing if necessary. The filter o-ring should be very lightly lubricated with GREASE™. When re-installing the ASA, take care not to cross-thread the ASA screws into the grip frame, as permanent damage may result.

DISASSEMBLY Full disassembly is only necessary to replace a leaking pin o-ring. This is accomplished by using a 7/64-inch hex wrench to unscrew the stainless nut from the back of the ASA. Seated in the front of the stainless nut is the ASA pin o-ring. This should be inspected and replaced if it shows any signs of wear or damage.

REGULATOR

Removal of the regulator's internal components is an advanced maintenance procedure that should only be performed when needed to repair a leak or lubricate seals if velocity becomes inconsistent with fresh, good quality paint and a clean bolt assembly.

SPRING PLATFORM REMOVAL With the Shocker® XLS unloaded and degassed, use a 5/16-inch hex key to unscrew the spring platform base [FIG. 27F] from the vertical regulator portion of the marker's body. If the hex key cannot fit far enough into the spring platform to get a good grip, use a 5/32-inch hex key to turn the velocity adjuster inward (counter-clockwise, it is reverse threaded) to expose more of the hexagonal flats in the spring platform. The adjuster spring is now attached to the back of the reg piston (VRG205) and will not drop freely.

SPRING PLATFORM ASSEMBLY Additional parts will come out, stacked inside the spring platform. These include the spring guide [FIG. 27A], regulator washer [FIG. 27B], relief valve [FIG. 27C], relief valve spring [FIG. 27D] and velocity adjuster [FIG. 27E]. The spring guide acts as a positioning seat for the regulator spring. The velocity adjuster is the base on which the spring guide sits. Turning the velocity adjuster changes the elevation of the spring platform to put more or less pressure on the regulator spring, ultimately determining the gas pressure inside the Shocker® XLS. The relief valve is a miniature, non-adjustable regulator that vents air out through the middle of the velocity adjuster if the Shocker® XLS is in danger of becoming over-pressurized.

REGULATOR PISTON Reach inside with an o-ring pick or needle nose pliers and pull the piston out by its spring to pull the regulator piston out [FIG. 28]. This is a difficult step. Patience and a gentle hand are required to achieve success. Take care not to slip and scratch the inner walls of the regulator body, as this may cause non-repairable leaks that will prevent the regulator from working correctly.

PLEASE READ CAREFULLY

26 SPRING PLATFORM

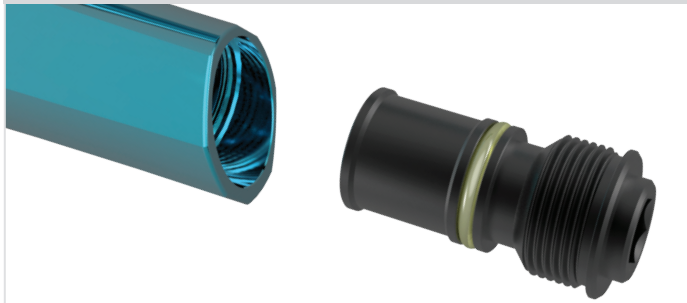

27 SPRING PLATFORM ASSEMBLY

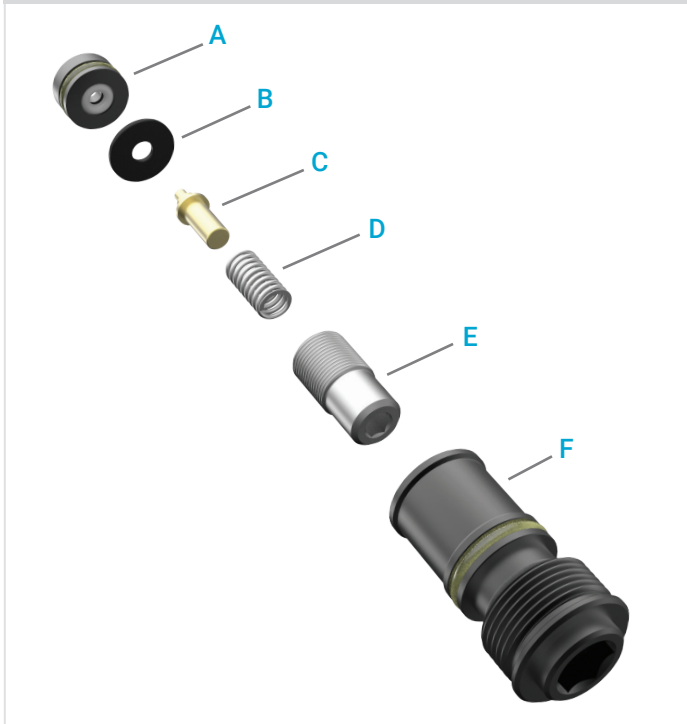

PISTON REMOVAL 28

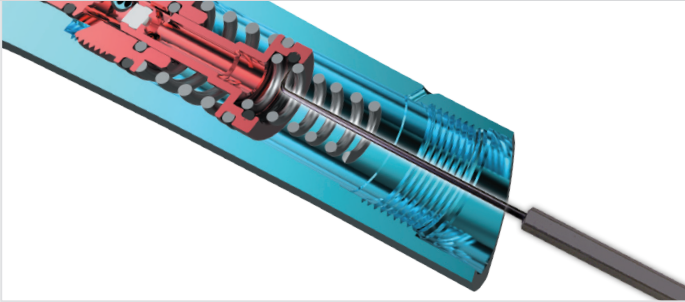

REGULATOR BASE 29

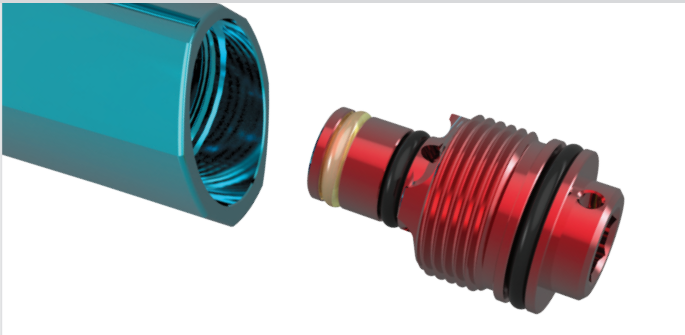

REGULATOR SEAT 30

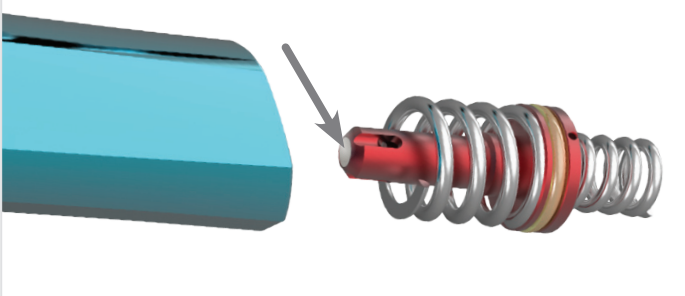

REGULATOR BASE Unscrew the regulator base from inside the regulator body with a 1/4-inch hex key. Once it is completely unscrewed, the regulator base [FIG 29] will need to be pulled from the regulator body with an o-ring pick, as was done with the regulator piston. Take great care not to scratch the regulator face, the flat surface surrounding the small opening in the center of the regulator base.

INSPECTION Carefully inspect and clean all removed components. Any seals or o-rings which show signs of wear or have dents or tears must be replaced. Pay special attention to the regulator seat, the small seal pressed into the tip of the regulator piston [FIG 30]. This seal, like many of the o-rings is a wear item and will eventually need to be replaced. A small, light circular depression in the regulator seat from where it presses up against the face in the regulator base is normal and not a problem. A deep circular depression, or chips or tears which are not a part of that circular imprint will lead to leaks and are a sign that the seal must be replaced. When replacing the regulator seat, take care not to misplace the regulator tip filter which sits below the regulator seat.

LUBRICATION Use GR33SE™ to lightly lubricate all o-rings except the o-ring inside the spring platform. This o-ring must provide friction to keep the velocity adjuster locked in to its setting. Do not lubricate the regulator seat in the tip of the piston.

REASSEMBLY The regulator components are reinstalled in the reverse order of disassembly. Both the regulator base and spring platform must be screwed in all the way for proper regulator operation. When testing the Shocker XLS after performing regulator maintenance, always wear paintball eye and face protection, even if only dry firing with no paintballs.

GRIP FRAME

Removal of the grip frame is an advanced maintenance procedure that should only be performed when needed to repair a leak or replace a damaged component.

GRIP AND BATTERY Using a 5/64-inch hex key remove the 6 grip screws and the wrap-around rubber grip. Gently slide the 9v alkaline battery out of the grip frame and unplug it from the battery clip. Take care not to pull on or strain the battery clip wires.

SOLENOID AND VISION™ WIRES Unplug the Vision™ wiring harness and the solenoid valve from the Shocker® XLS circuit board. This is best done with an o-ring pick pulling on the top edge of each plug, as pulling on the wires may tear them free of the plug.

CIRCUIT BOARD It is possible to remove the grip frame from the body of the Shocker® XLS with the circuit board still in place, however removing it first makes it much easier to properly place the Vision™ wiring harness. Using a 1/16-inch hex key remove the two circuit board screws from the right hand side of the grip frame [FIG. 32]. Carefully lift the circuit board out of the right hand side of the grip frame. Note that the circuit board is connected to the XLS data display by a 12-pin header connector. This connector must be aligned and seated properly when the circuit board is reinstalled.

XLS DATA DISPLAY The XLS data display may be left in place too when removing the grip frame. If it must be removed to be replaced, simply use a 1/16-inch hex key to remove the two XLS data display screws from the left side of the grip frame and slide the data display out the back [FIG. 33]. The data display circuit board slides out of its bezel. Note the difference in length between the data display and XLS circuit board screws to select the appropriate screws during reassembly.

GRIP FRAME Use a 1/8-inch hex key to remove the front and rear grip frame screws. Gently slide the grip frame away from the receiver, making sure the Vision™ wiring harness and solenoid valve plugs do not catch on the grip frame.

PLEASE READ CAREFULLY

31 VISION™ AND SOLENOID PLUGS



32 CIRCUIT BOARD



33 RSX DATA DISPLAY



34 GRIP FRAME



GAS-THROUGH SEAL 35

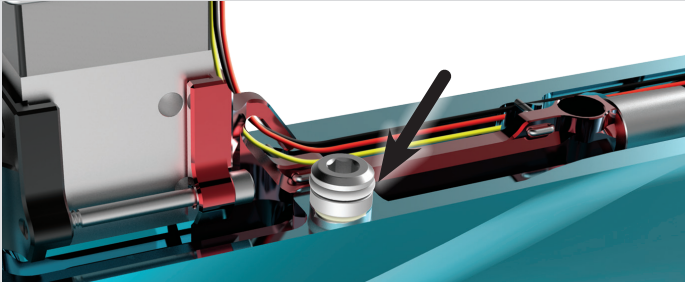

REASSEMBLY Reassemble the grip frame to the receiver in the opposite order of removal. Clean and inspect the gas-through seal [FIG. 35], and lightly lubricate it with GR33SE™. Make sure Vision™ wires are not pinched and the rear wire securing pin is folded out of the way.

TRIGGER 36



TRIGGER The Shocker® XLS pivots on a pair of bearing sets nested onto a low friction pin. Using a 1/16-inch hex wrench, unscrew and remove the trigger pivot pin [FIG. 36] and the trigger may be removed from the top of the grip frame when it is separate from the Shocker® XLS body. Be sure to tighten the trigger pivot screws evenly when reinstalling so that the trigger is centered in the frame. Do not over-tighten these screws or the bearing sets will be damaged and the trigger will not pivot smoothly. The screws may be left slightly loose for players who prefer a looser trigger feel with some side to side play.

VISION™ WIRING HARNESS 37

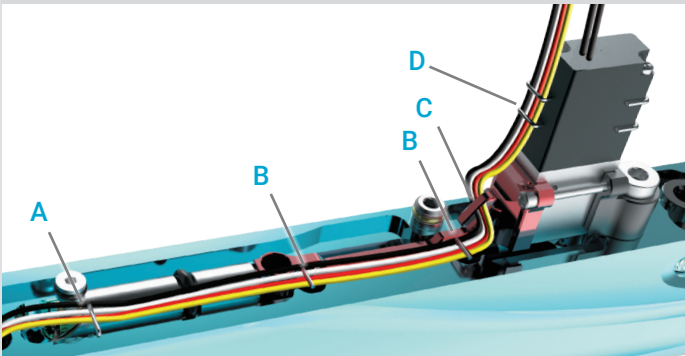

VISION™ WIRING HARNESS The Vision™ wiring harness is secured in place by two wire clips wrapping around the solenoid valve [FIG. 37D], two pins on the bolt control manifold [FIG. 37B] and QEV lock pin [FIG. 37A]. To remove the Vision™ wiring harness, remove the clips securing it to the solenoid valve. Work the wires one at a time out of the hook at the base of the manifold [FIG. 37C]. Remove the bolt control manifold, following the instructions in this manual. The Vision™ covers may be removed and the sensor circuit boards lifted from their pockets, then passed through and out of the bottom of the body for complete removal of the Vision™ wiring harness.

REASSEMBLY When reinstalling, or installing a replacement Vision™ wiring harness, all wires must be completely within wire channel in the right side of the body and secured in place by the bolt control manifold and clips to ensure that they do not become pinched between the body and grip frame, which may cause permanent damage.

BOLT CONTROL MANIFOLD The bolt control manifold [FIG. 39B] connects the supply of regulated compressed air to the solenoid valve and the forward control section of the bolt assembly. At the front of the bolt control manifold is the rebuildable quick exhaust valve (QEV) [FIG. 39C] that vents air from the control section when the bolt closes to fire the Shocker® XLS.

Before removing the bolt control manifold, unclip the Vision wiring harness from the solenoid and unhook it from the rear of the manifold. The Vision™ sensors do not need to be removed from the body, only the wires must be released from the manifold.

38 REMOVE VISION™ WIRES

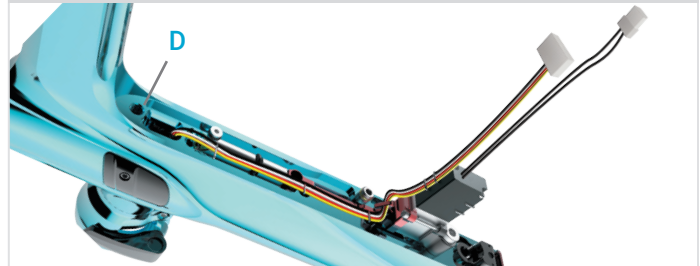

39 MANIFOLD ASSEMBLY

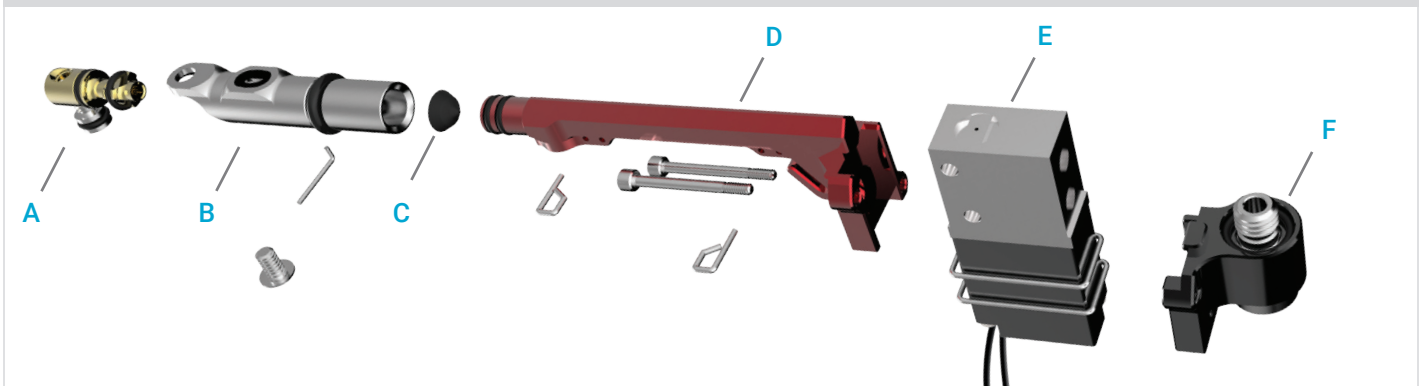

Using a 1/16-inch hex key, remove the QEV mount screw [FIG. 38D] from the front of the bolt control manifold. Using a 1/8-inch hex key unscrew the gas-through bolt [FIG. 39E] from the manifold inlet at the rear.

Once removed, the bolt control manifold may be further disassembled as needed for repair. The QEV slides off of the manifold. The QEV may be disassembled by removing its pin, sliding out the QEV core [FIG. 39A] and pushing the QEV diaphragm [FIG. 39C] out with a 1/16-inch hex key. The same hex key may be used to release the manifold inlet and solenoid valve.

The trigger return magnet is secured in the bolt control manifold by dimpling the aluminum manifold body with a

punch. It is non-removable. The black socket head cap screw in the rear of the manifold plugs the rear of the manifold after it is machined and does not need to be removed.

REASSEMBLY Before reassembly, lubricate o-rings *very sparingly* with GR33SE™. Excess lubricant can clog small gas paths in the solenoid valve or QEV, preventing proper operation. Do not lubricate the QEV diaphragm.

Reassemble in reverse order of removal and disassembly. When reassembling, be sure the cone in the center of the QEV diaphragm is pointed back, toward the solenoid valve.

SHOCKER® XLS IS BREAKING PAINT IN THE BREECH OR BARREL.

- Paint is too large for barrel - Check paint to barrel fit and if necessary switch to a larger bore Freak™ insert or smaller paint.
- Paint is inconsistent in size or shape - Old paint or paint that is lumpy and out of round will not shoot well. Switch to fresh, good quality paintballs.
- Ball detents are damaged or dirty - Inspect and clean the ball detents as described in the Ball Detent section of this manual.
- Paint is brittle - Decreasing the bolt closing force will adapt the Shocker® XLS to be extra gentle with brittle paintballs. See the QEV Adjustment section of this manual.
- Battery is too weak - A weak battery will be incapable of holding the solenoid valve open for the full dwell time resulting in short-strokes of the valve system. Replace the battery with a new name brand alkaline battery.
- Loader is too slow - The loader may not be keeping pace with the Shocker® XLS. Test with another loader. Make sure Vision™ is enabled.

WHEN GASSED UP AIR LEAKS FROM BETWEEN THE GRIP FRAME AND BODY.

- Manifold assembly o-rings may be damaged or worn - Inspect, clean and if necessary replace o-rings in the manifold assembly following the instructions in the Bolt Control section of this manual.
- Gas through seal is damaged or worn - Inspect, clean and if necessary replace the gas-through seal following the instructions in the Grip Frame section of this manual.
- Grip frame is not fully seated into body - Check to make sure the grip frame is fully seated in the body. An improperly positioned QEV pin or Vision wiring harness may prevent the grip frame from fully seating.

WHEN GASSED UP AIR LEAKS FROM THE BOTTOM OF THE GRIP FRAME.

- ASA gas-through o-ring is damaged or missing - Inspect, clean and if necessary replace the ASA gas-through o-ring following the instructions in the ASA section of this manual.

BOLT ASSEMBLY WILL NOT SLIDE SMOOTHLY INTO BODY OR LOCK IN PLACE.

- O-rings are damaged or un-seated - Follow the bolt cleaning procedure and make sure all o-rings are in good condition and properly seated. Also make sure there is no debris inside the body. Pressing the bolt release button before the Shocker® XLS has been de-gassed is a common cause of un-seated o-rings and should be avoided.

AIR LEAKS DOWN THE BARREL WHEN GASSING UP.

- One or more o-rings in the bolt system are damaged or worn
- Clean and inspect, following the instructions in the Bolt Cleaning section of this manual. Pay special attention to the inner o-ring of the chamber guide [FIG. 18C].

SHOCKER® XLS WILL NOT TURN ON OR TURNS OFF ON ITS OWN, ESPECIALLY DURING RAPID FIRING.

- Battery may be low or dead - Replace with a brand new, name-brand alkaline battery. Some rechargeable batteries may not work well with the Shocker® XLS.
- The battery wiring harness may have become damaged
- Inspect the battery wiring harness and replace if necessary

WHEN GASSED UP, LITTLE OR NO AIR SEEMS TO BE GETTING TO THE SHOCKER®.

- Bolt cannot move - Follow the Bolt Cleaning section of this manual to clean and inspect the o-rings of the bolt system.
- ASA air filter is clogged - Inspect and if necessary replace the ASA filter following the instructions in the ASA section of this manual.
- Solenoid valve air filter is clogged - Inspect and if necessary replace the solenoid valve filter following the instructions in the Bolt Control section of this manual.

TRIGGER FRAME AND BODY WON'T ALIGN.

- If trigger frame will not install onto body make sure PIN012 is aligned properly.

AIR LEAKS OUT THROUGH THE VELOCITY ADJUSTER.

- Damaged or worn seal in spring platform assembly causing continuous leak - Inspect clean and if necessary replace o-rings and relief valve seal from spring platform assembly following the instructions in the Regulator section of this manual.
- Damaged or worn regulator piston or regulator base o-rings or regulator seat causing intermittent leak - Damaged components causing the regulator to “run hot” will result in the relief valve repeatedly venting excess pressure through the velocity adjuster. Inspect, clean and if necessary replace all regulator o-rings and seals.
- Visit shockerpaintball.com for leak point images to identify cause of leak.

AIR LEAKS OUT THROUGH THE LOWER REGULATOR VENT HOLE.

- Damaged or worn outer spring platform o-ring - Clean, inspect and if necessary replace the outer spring platform o-ring following the instructions in the Regulator section of this manual.
- Visit shockerpaintball.com for leak point images to identify cause of leak.

AIR LEAKS OUT THROUGH THE MIDDLE REGULATOR VENT HOLE.

- One of the following o-rings is damaged or worn: regulator piston o-ring, inner or lower outer regulator base o-ring - Clean inspect and if necessary replace bad o-rings following the instructions in the Regulator section of this manual.
- Visit shockerpaintball.com for leak point images to identify cause of leak.

AIR LEAKS OUT THROUGH THE TOP REGULATOR VENT HOLE.

- One of the upper two regulator base o-rings is damaged or worn - Clean inspect and if necessary replace bad o-rings following the instructions in the Regulator section of this manual.
- visit shockerpaintball.com for leak point images to identify cause of leak.

THE SHOCKER® XLS IS UNLOCKED AND ALWAYS ENTERS PROGRAMMING MODE WHEN TURNED ON.

- Trigger is out of adjustment and depressing the trigger switch.
- Adjust the trigger following the instructions in the Trigger Adjustment section of this manual.

THE TRIGGER DOES NOT MOVE WHEN PULLED OR THE CLICK OF THE TRIGGER SWITCH CANNOT BE HEARD ON BOTH THE PULL AND RELEASE OF THE TRIGGER.

- Trigger is out of adjustment - Adjust the trigger following the instructions in the Trigger Adjustment section of this manual.
- Loosen trigger pivot pin slightly.
- The trigger switch is damaged - Remove the circuit board, following the instructions in the Grip Frame section of this manual. If the trigger switch does not make a clicking sound when pressed and released, the trigger switch has been damaged, possibly by incorrect trigger adjustment. Replace the circuit board and follow the trigger adjustment instructions in this manual.

THE SHOCKER® XLS SUFFERS FROM FIRST SHOT DROP OFF.

- Shocker® XLS fires at a low velocity or will not fire on the first trigger pull after sitting still for a few minutes, but fires at proper velocity on all subsequent shots, this first shot drop off may be caused by dirt or under-lubrication. Degas, disassemble, clean and inspect the bolt assembly following the instructions in the Bolt Cleaning section of this manual.
- If first shot drop off continues after cleaning and lubrication, progressively increase the FSDO Adjust and decrease the FSDO timer values until the first shot fires at the same velocity as the shots which follow it. For further instruction on changing these values, see the Settings section of this manual.

THE SHOCKER® XLS FIRES FASTER THAN ALLOWED AT MY PAINTBALL FIELD.

- The extremely high rates of fire that can be achieved by the Shocker® XLS can be intimidating to newer players. Using a capped firing mode with lower BPS Limit and BPS Fine values can restrict the Shocker® XLS maximum rate of fire to acceptable levels for the field where you play. For further instruction on changing these values, see the Settings section of this manual.

FIRING CAN

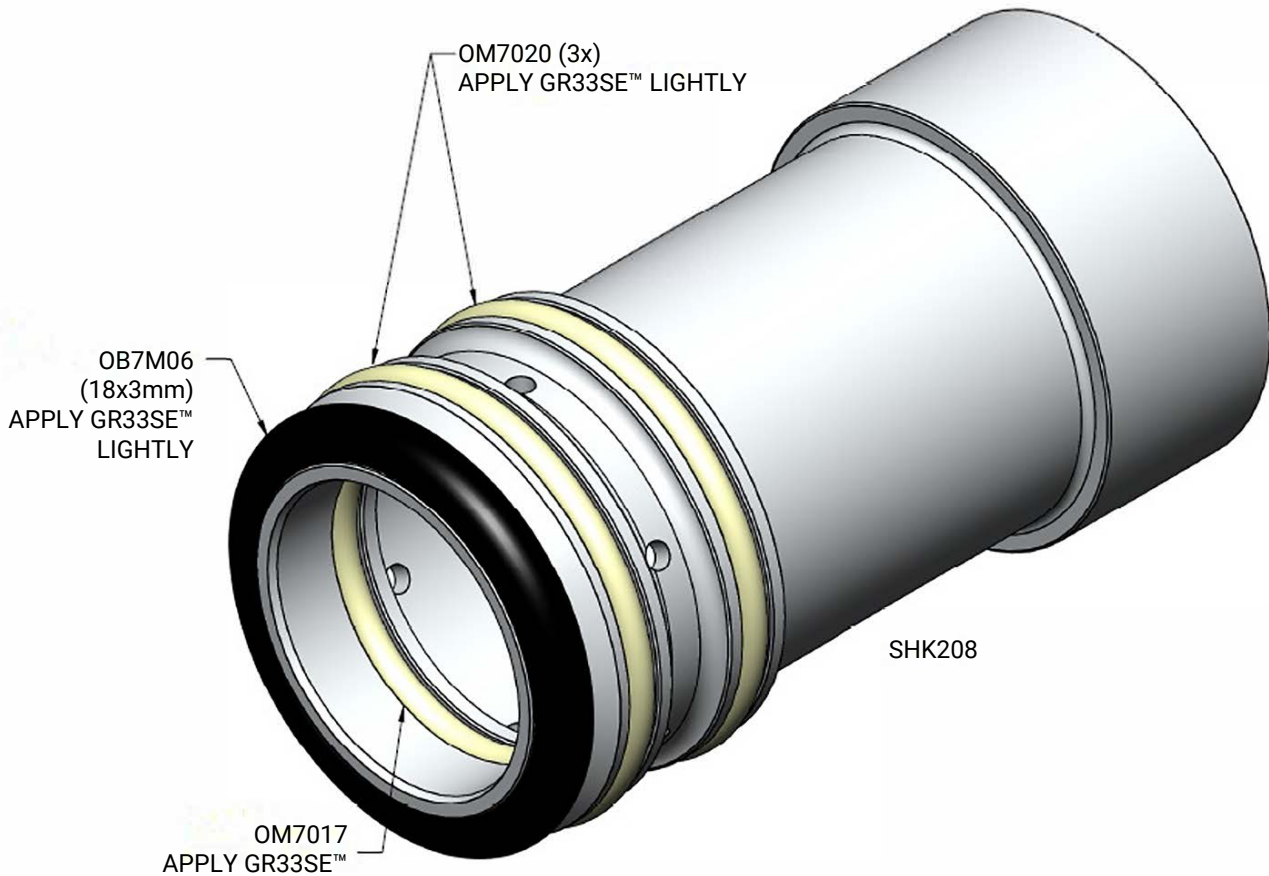

CHAMBER GUIDE

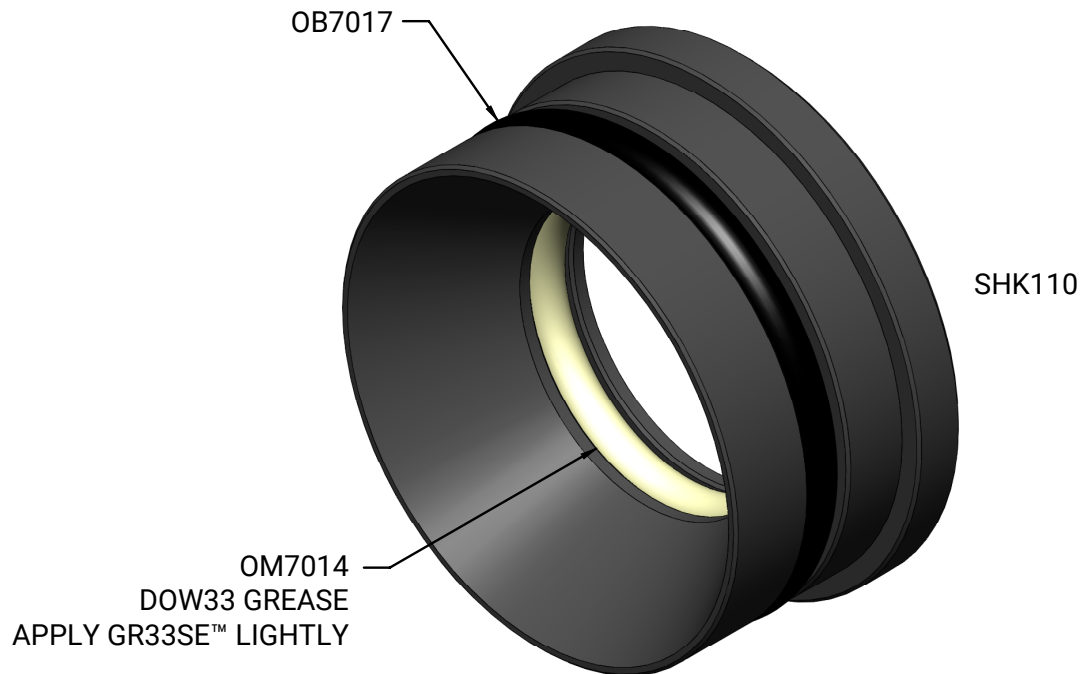

MAIN CHAMBER

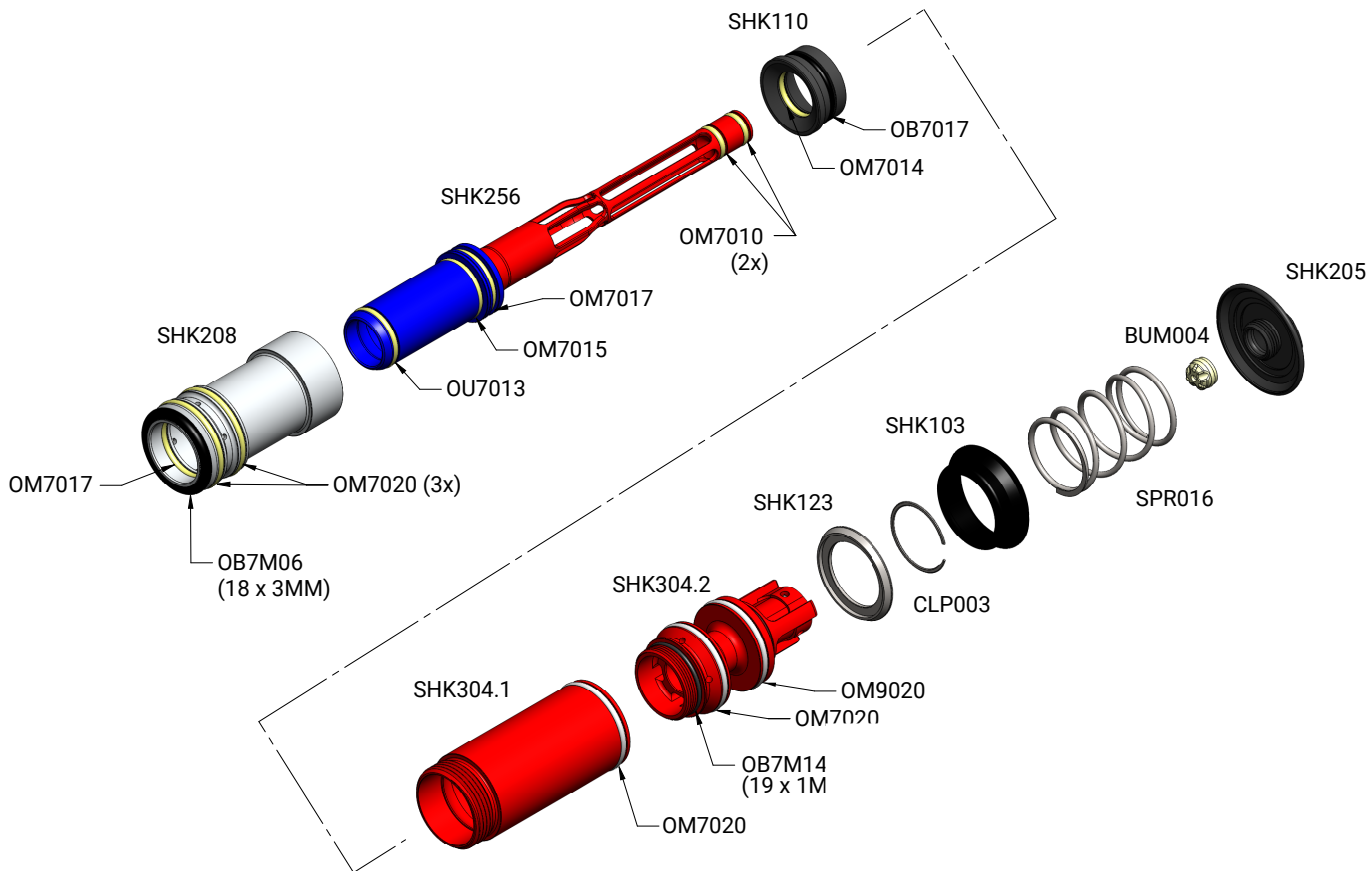

BOLT

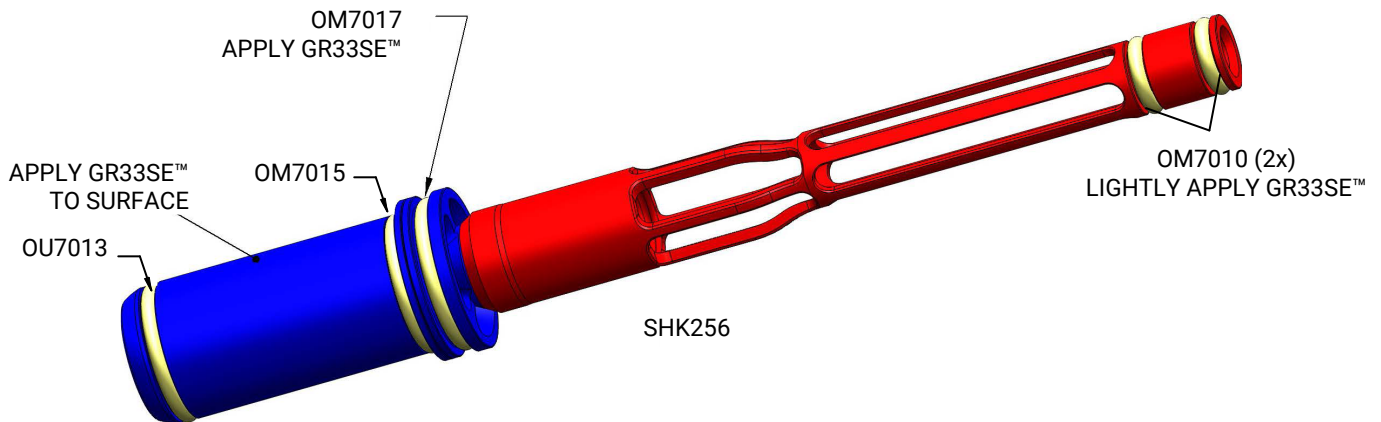

SOLENOID VALVE MANIFOLD

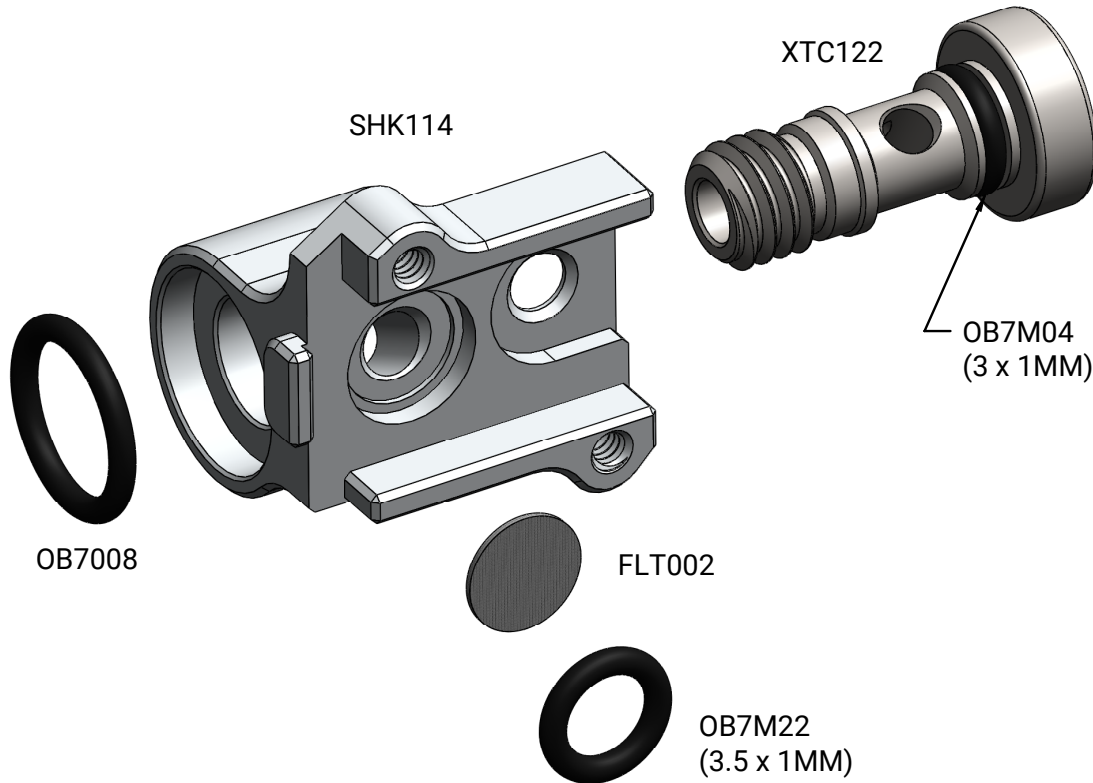

BOLT CONTROL MANIFOLD

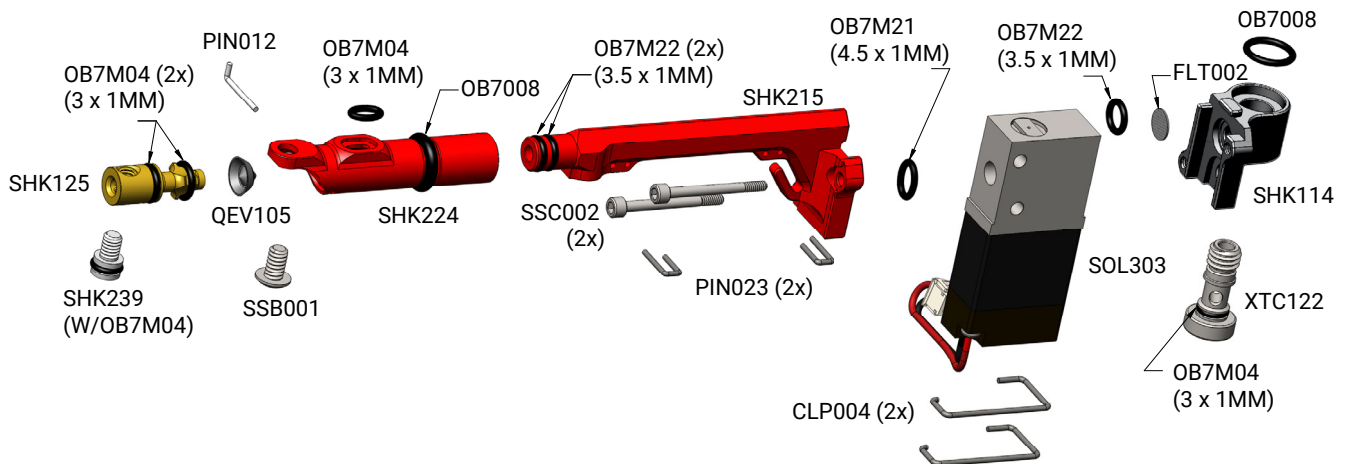

LATCH ASSEMBLY

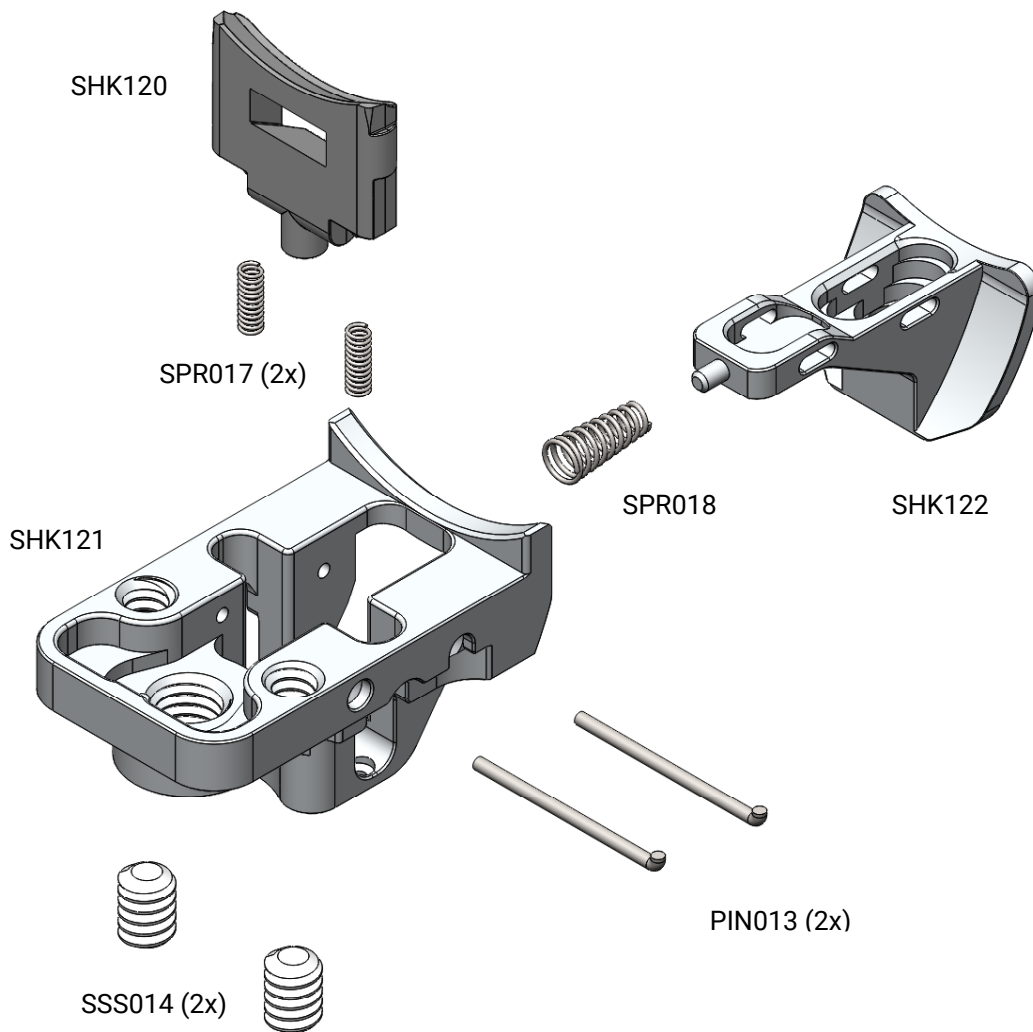

VISION™ COVER

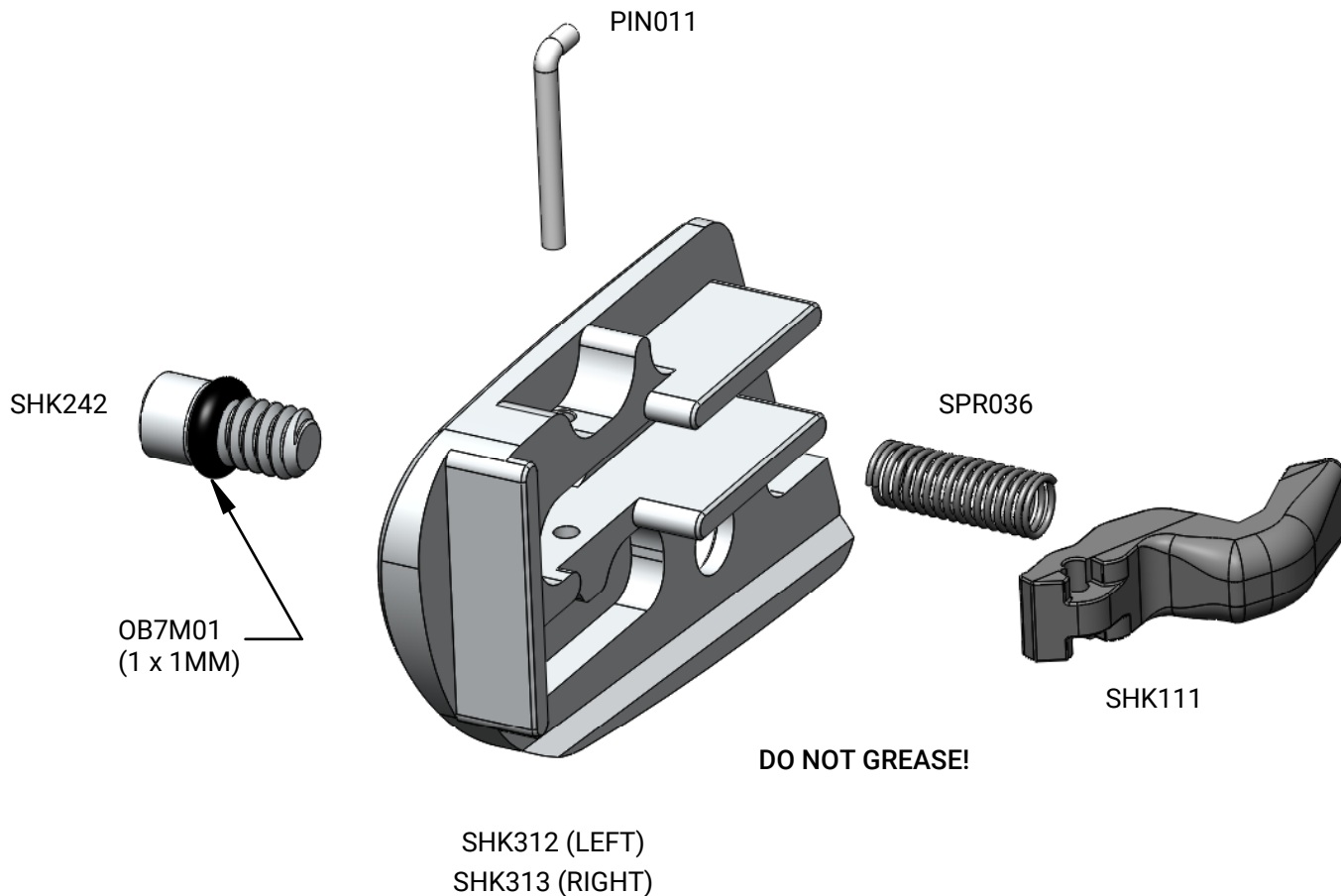

CLAMPING FEEDNECK

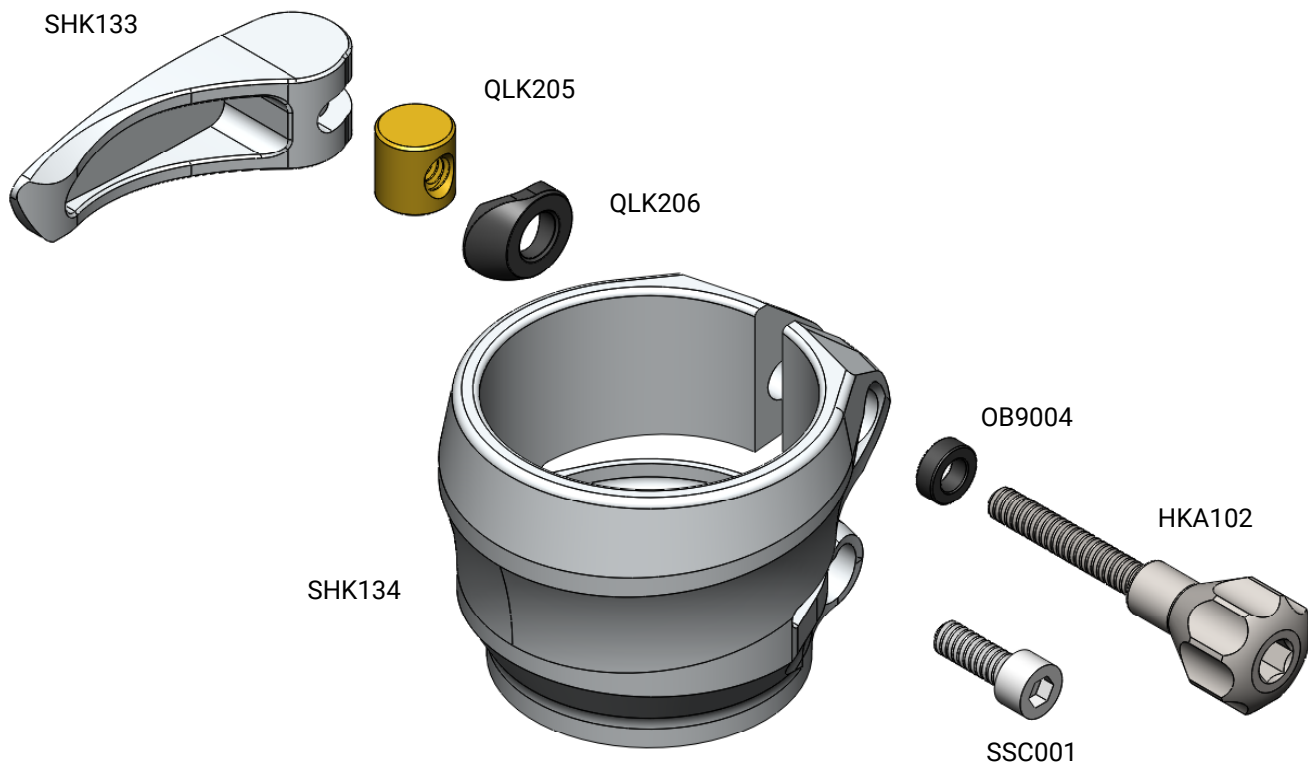

REGULATOR SPRING GUIDE

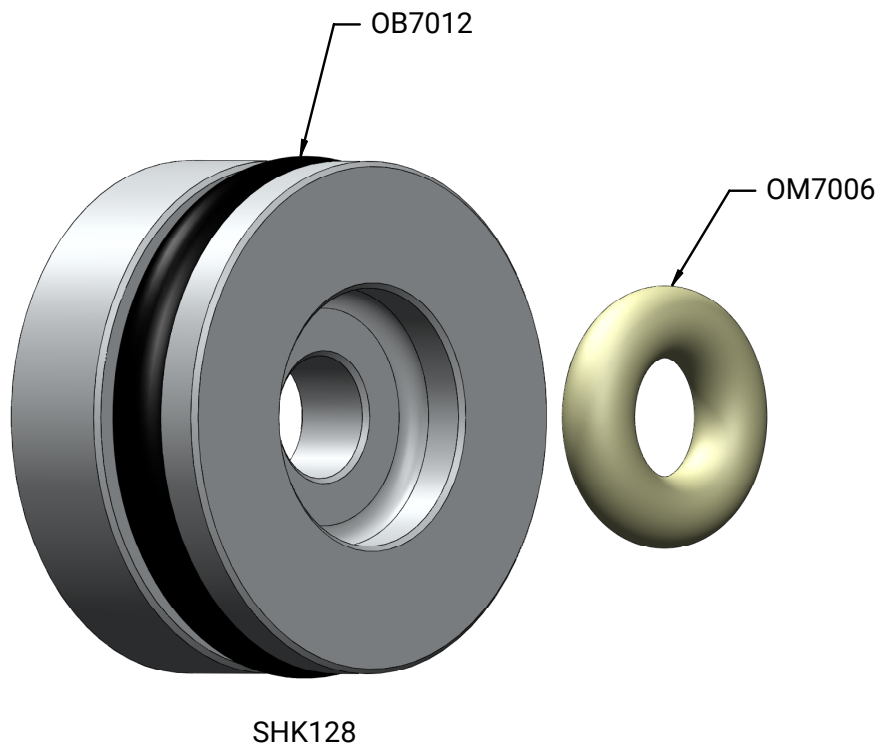

REGULATOR PISTON

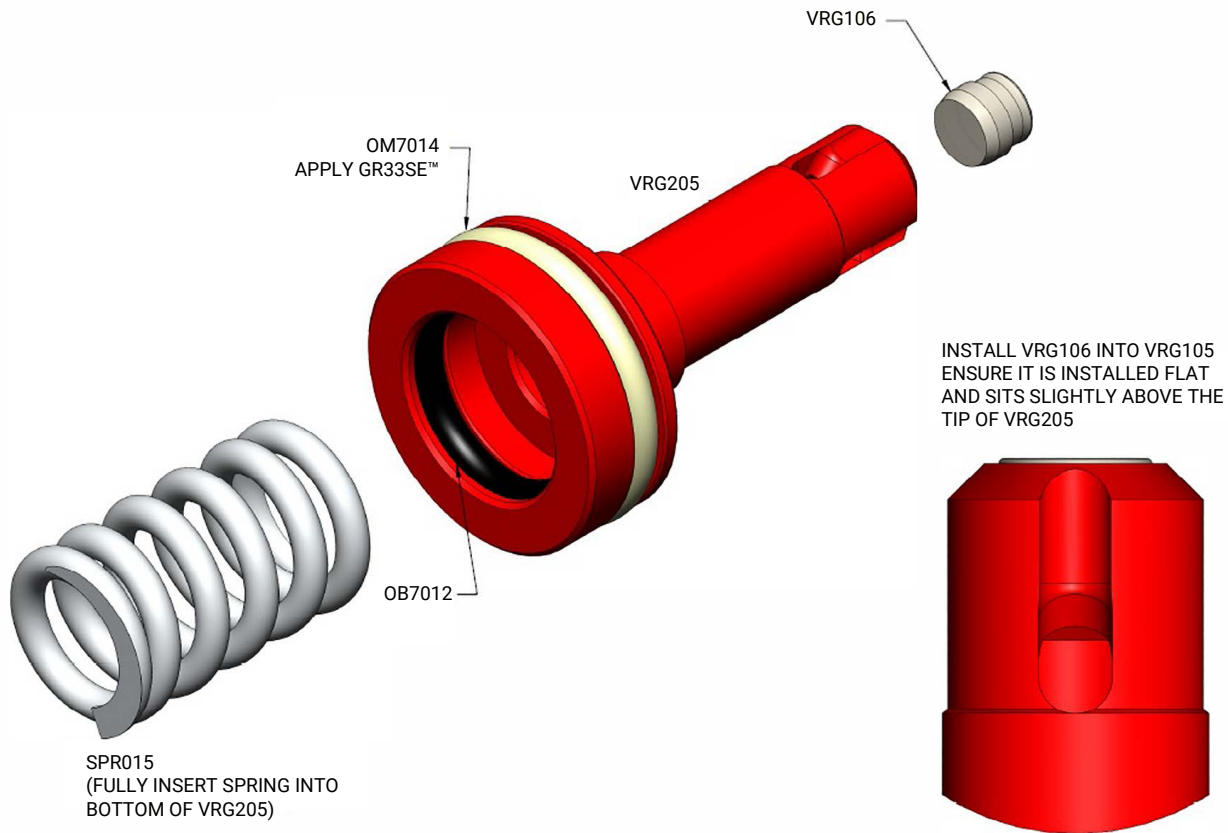

REGULATOR BASE

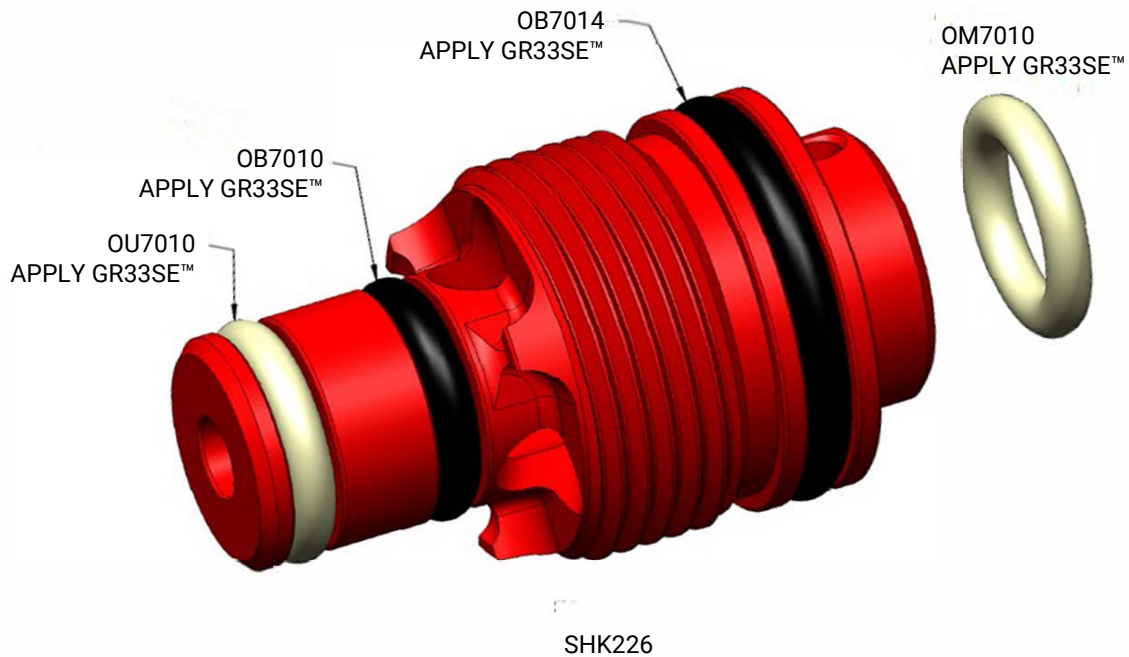

SPRING PLATFORM BASE

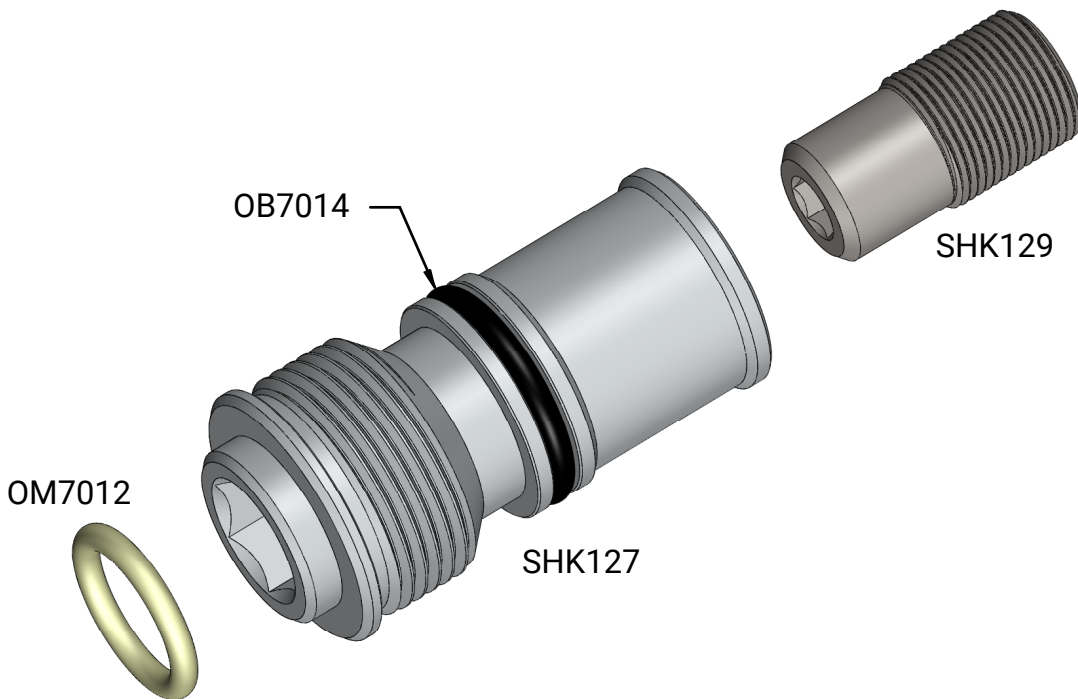

REGULATOR SPRINGS

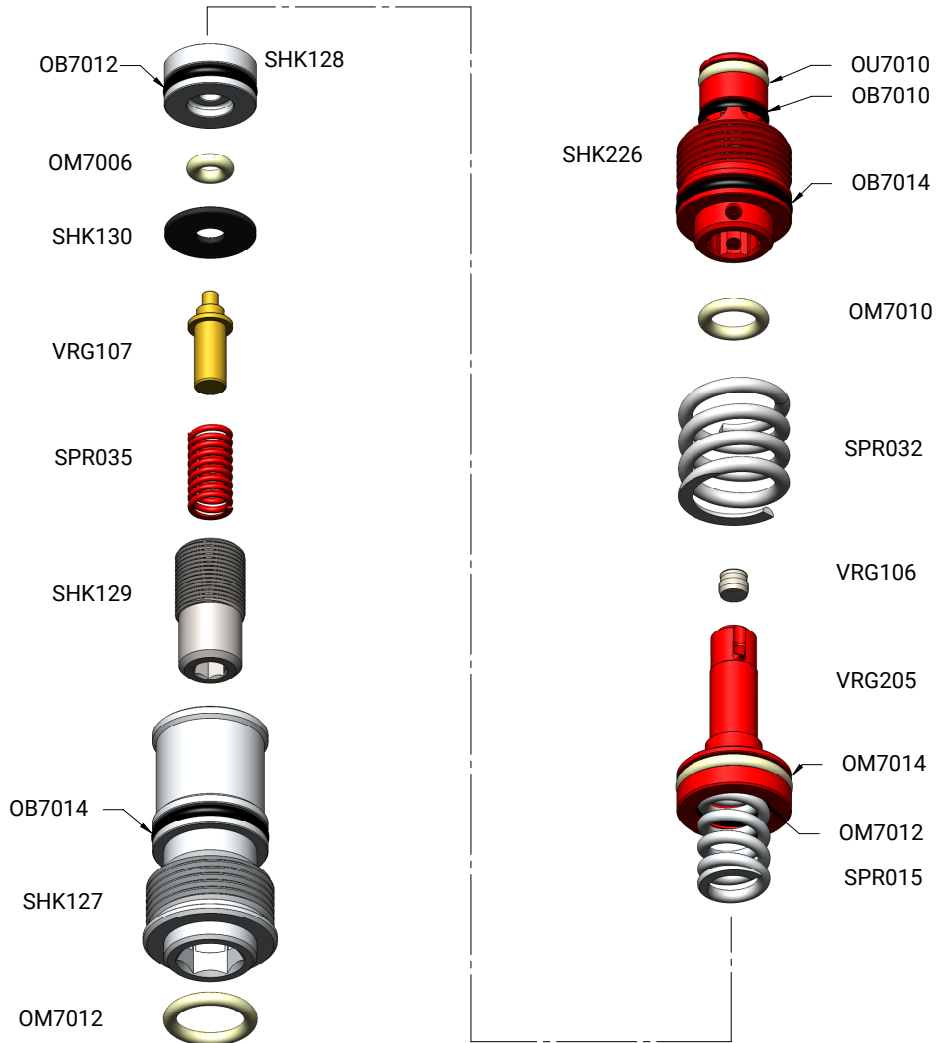

BODY SCREWS

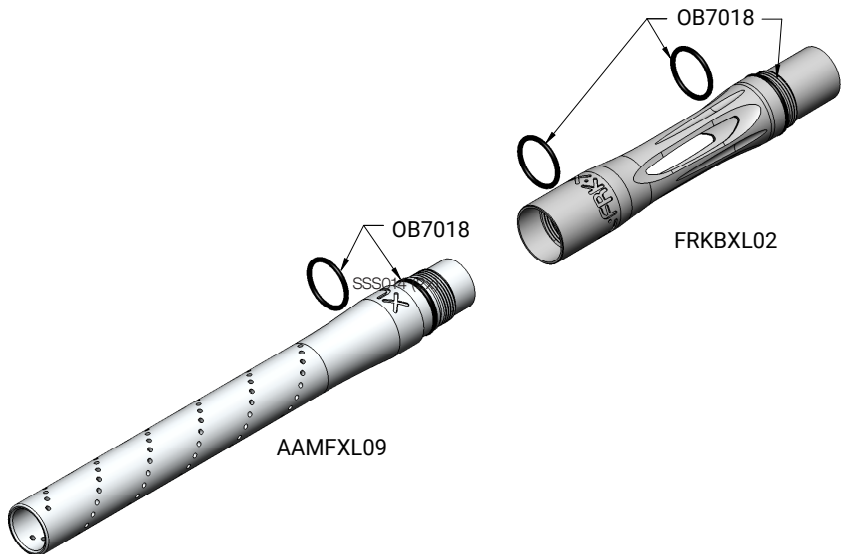
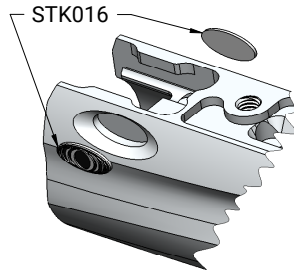
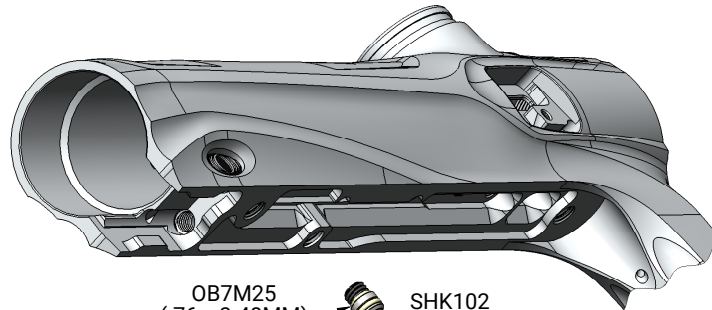
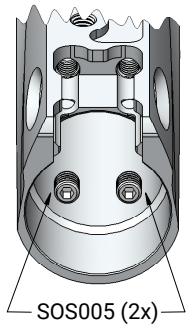

BOTTOM LINE ASA

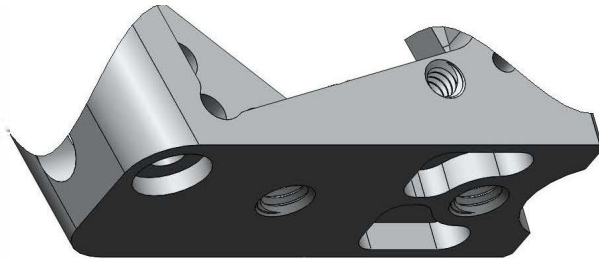

SHK206
BOTTOM OF FRAME

FLT004



OM9007



SSC010 (2)
BLUE LOCTITE 242



SHK237

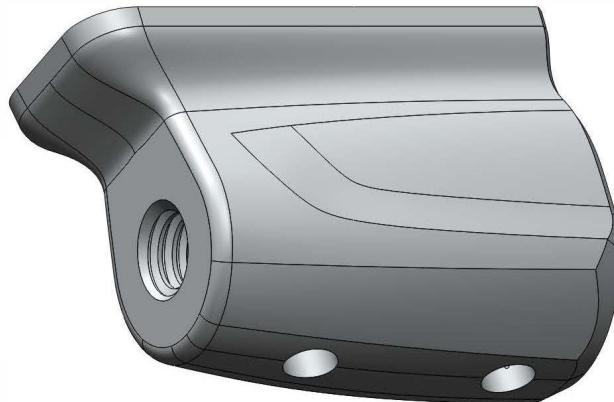

SHK236



SHK138

OU9005
APPLY GR33SE™

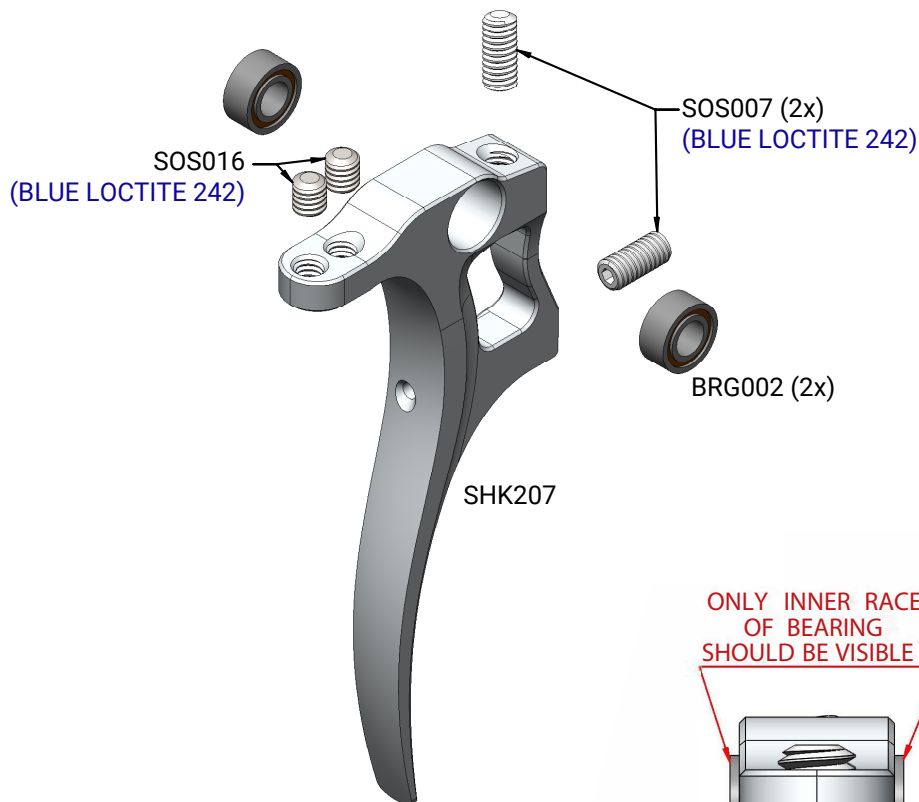

**ENSURE BEARING
OUTER RACE IS FLUSH
WITH BOTH OUTSIDE
SURFACES OF TRIGGER**

GRIP FRAME



PLEASE READ CAREFULLY

WARRANTY

TECH SUPPORT

Our Technical Support Department is open Monday through Friday, from 10am to 6pm EST, and can be reached at 724-520-8690. Additional support and downloadable product manuals are available through our web site: www.shockerpaintball.com.

Shocker Paintball warrants to initial retail purchaser that the Shocker® XLS paintball marker is free from defects in materials and workmanship for one year from date of purchase. This warranty is limited to the repair or replacement of defective parts with the customer to pay shipping costs. Disposable wear items (o-rings, spings, seals, screws, rubber grips, etc.) are not warranted. This warranty does not cover surface damage (scratches and nicks) damage resulting from misuse, improper disassembly, reassembly or attempts to drill holes or otherwise modify the marker. Trigger alteration of any kind may result in serious injury and will void the warranty. The only authorized lubricant for the Marker is Dow 33 based lubricant (GR33SE™). Use of any other lubricant may invalidate warranty. This warranty is effective only if the customer registers the product online at shockerpaintball.com within 30 days of purchase. Warranty is non-transferrable.



SP

WWW.SHOCKERPAINTBALL.COM

100 STATION ST. | LOYALHANNA, PA 15661 | (724) 520-8690
MANUAL VERSION 1.0

Shocker® and Freak® are registered trademarks owned by G.I. Sportz, Inc. and used under license by Philadelphia Americans, LLC.
Loctite® is a registered trademark of Henkel AG & Company KHaA.