



GEO



**OPERATORS
MANUAL**

⚠ WARNING**ADHERE STRICTLY TO THESE AND ALL OTHER SAFETY INSTRUCTIONS AND GUIDELINES!**

01. The Eclipse Geo is not a toy.
02. Careless or improper use, including failure to follow instructions and warnings within this User Manual and attached to the Geo could cause death or serious injury.
03. Do not remove or deface any warnings attached to the Geo.
04. Paintball industry standard eye/face/ear and head protection designed specifically to stop paintballs and meeting ASTM standard F1776 (USA) or CE standard (Europe) must be worn by user and any person within range.
05. Persons under 18 years of age must have adult supervision when using or handling the Geo.
06. Observe all local and national laws, regulations and guidelines.
07. Use only professional paintball fields where codes of safety are strictly enforced.
08. Use compressed air/nitrogen only. Do not use CO₂
09. Always follow instructions, warnings and guidelines given with any first stage regulator you use with the Geo.
10. Use 0.68 calibre paintballs only.
11. Keep the Geo switched off until ready to shoot.
12. Treat every marker as if it is loaded.
13. Never point the Geo at anything you do not intend to shoot.
14. Do not shoot at persons at close range.
15. Always measure your markers velocity before playing paintball, using a suitable chronograph.
16. Never shoot at velocities in excess of 300 feet (91.44 meters) per second, or at velocities greater than local or national laws allow
17. Do not 'gas up' the Geo without the Bolt assembly correctly installed, as high-pressure gas will be emitted.
18. Never look into the barrel or breech area of the Geo whilst the marker is switched on and able to fire.
19. Never put your finger or any foreign objects into the paintball feed tube of the Geo.
20. Never allow pressurised gas to come into contact with any part of your body.
21. Always switch off the Geo when not in use.
22. Always fit a barrel-blocking device to the Geo when not in use on the field of play.
23. Always remove all paintballs from the Geo when not in use on the field of play.

⚠ WARNING**ADHERE STRICTLY TO THESE AND ALL OTHER SAFETY INSTRUCTIONS AND GUIDELINES!**

24. Always relieve all residual gas pressure from the Geo before removing the first stage regulator.
25. Always remove the first stage regulator and relieve all residual gas pressure from the Geo before disassembly.
26. Always remove the first stage regulator and relieve all residual gas pressure from the Geo for transport and storage.
27. Always follow guidelines given with your first stage regulator for safe transportation and storage..
28. Always store the Geo in a secure place..



THIS USERS MANUAL IS IN ENGLISH. It contains important safety guidelines and Instructions. Should you be unsure at any stage, or unable to understand the contents within this manual you must seek expert advice.

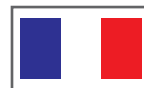

LE MODE D'EMPLOI EST EN ANGLAIS. Il contient des instructions et mesures de sécurité importantes. En cas de doute, ou s'il vous est impossible de comprendre le contenu du monde d'emploi, demandez conseil à un expert.



ESTE MANUAL DE USUARIOS (OPERARIOS) USARIOS ESTÁ EN INGLÉS. Contiene importantes normas de seguridad e instrucciones. Si no está seguro de algún punto o no entiende los contenidos de este manual debe consultar con un experto.



DIESE BEDIENUNGS - UND BENUTZERANLEITUNG IST IN ENGLISCH. Sie enthält wichtige Sicherheitsrichtlinien und -bestimmungen. Sollten Sie sich in irgendeiner Weise un sicher sein. Oder den inhalte dies heftes nicht versthén, lassen Sie sich bitte von einen Experten beraten.

NOTE: THIS USER MANUAL MUST ACCOMPANY THE PRODUCT IN THE EVENT OF RESALE OR NEW OWNERSHIP. SHOULD YOU BE UNSURE AT ANY STAGE YOU MUST SEEK EXPERT ADVICE! (SEE SERVICE CENTERS PAGE 76-77)

6 ORIENTATION

Names the component parts of the Geo Marker. This section is essential reading for everyone.

- 6 > KNOW YOUR GEO
- 7 > ECLIPSE SHAFT 3 BARREL
- 8 > INLINE REGULATOR
- 9 > GEO BOLT SYSTEM
- 10 > GEO SOLENOID ASSEMBLY
- 11 > OPERATIONAL OVERVIEW
- 12 > GEO NAVIGATION CONSOLE

13 QUICK SET-UP

Details on how to get up and running quickly with your Geo. This section is essential reading for everyone.

- 13 > INSTALLING A 9V BATTERY
- 14 > SWITCHING ON THE GEO
 - > SWITCHING OFF THE GEO
 - > FIRING THE GEO
 - > THE GEO CIRCUIT BOARD
- 15 > USING THE BREAK BEAM SENSOR SYSTEM

16 USING YOUR GEO

More detailed information on how to use and interact with the Geo via its user interface.

- 16 > SETTING UP
 - > INSTALLING A PRESET AIR SYSTEM
- 17 > T-SLOT MOUNTING SYSTEM
 - > MACROLINE HOUSING & ELBOWS
- 18 > INSTALLING AN ADJUSTABLE AIR SYSTEM
- 19 > ATTACHING A LOADER
- 20 > SETTING THE TRIGGER
- 22 > ADJUSTING THE VELOCITY
 - > ADJUSTING THE FIRING CHAMBER VOLUME
- 23 > USER INTERFACE
 - > SWITCHING ON
 - > RUN SCREEN LAYOUT
- 24 > UNDERSTANDING THE BBSS INDICATOR
- 25 > UNDERSTANDING THE SOUND INDICATOR
 - > UNDERSTANDING THE TRIGGER DETECTION INDICATOR

- 26 > UNDERSTANDING THE LOCK INDICATOR
 - > UNDERSTANDING THE BATTERY INDICATOR
 - > THE GAME TIMER
 - > THE SHOT COUNTER
- 27 > THE AVERAGE RATE OF FIRE
 - > THE PEAK RATE OF FIRE
 - > THE MENU SYSTEM

28 MENU TREE

A quick reference guide to the user interface.

- 28 > MAIN MENU
- 29 > SET-UP MENU

32 ADVANCED SET-UP

In depth information on setting up the Geo.

- 32 > ACCESSING THE MENU SYSTEM
 - > MOVING AROUND THE MENUS
 - > ALTERING PARAMETERS
- 33 > THE MAIN MENU
 - > DISPLAY -The Display Parameter
- 34 > TIMER -The Game Timer Menu
 - > GAME -The Game Time Parameter
- 35 > ALARM -The Alarm Time Parameter
 - > START -The Timer Start Parameter
- 36 > THE SET-UP MENU
- 37 > LOCK -The Tournament Lock Parameter
 - > PRESET -The Preset Menu
 - > LOAD -The Load Preset Parameter
- 38 > SAVE -The Save Preset Parameter
 - > MODE -The Firing Mode Parameter
- 39 > ROF CAP -Rate of Fire Cap Parameter
 - > MAX ROF -Maximum Rate of Fire Parameter
- 40 > OFF ROF -Rate of Fire With BBSS Off Parameter
 - > RMP SET -The Ramp Settings Menu
- 41 > TYPE -The Ramp Type Parameter
 - > RATE -The Linear Ramp Rate Parameter
- 42 > PULL NO -The Ramp Start Parameter
 - > KICK IN -The Ramp Kick-In Parameter
- 43 > SUSTAIN -The Sustain Rate Parameter
 - > RESTART -The Ramp Restart Parameter

- 44 > TIMING -The Timing Menu
 - > DWELL -The Dwell parameter
 - > FSD COMP -The First Shot Drop-off Compensation Parameter
 - > FSD DLY -The First Shot Drop-off Delay Parameter
- 45 > LIGHT -The Light Parameter
 - > SLEEP -The Sleep Parameter
- 46 > FILTER -The Filter Menu
- 47 > DBOUNCE -The Debounce Parameter
 - > EMPTY -The Empty Breech Time Parameter
- 48 > FULL -The Full Parameter
 - > PULL TM -The Pull Time Parameter
- 49 > REL TM -The Release Time Parameter
 - > PULL PT -The Pull Point Parameter
- 50 > REL PT -The Release Point Parameter
 - > BASIC TRIGGER FILTER SET-UP
 - > ADVANCED TRIGGER FILTER SET-UP
- 51 > TRAININ -The Training Parameter
- 52 > THE HARDWARE MENU
 - > TRIGGER -The Trigger Parameter
 - > SOUND -The Sound Parameter
 - > TONES -The Tones Parameter

53 MAINTENANCE

A guide to performing routine maintenance.

- 54 > CLEANING THE BREAK BEAM SENSOR SYSTEM
- 56 > CLEANING THE INLINE REGULATOR
- 58 > MAINTAINING THE GEO BOLT SYSTEM
- 62 > HOW TO REMOVE THE FRAME
- 65 > THE GEO SOLENOID ASSEMBLY
- 68 > THE GEO TRIGGER ASSEMBLY
- 70 > THE GEO ON/OFF PURGE SYSTEM

72 FAULT FINDING

Information on how to resolve any problems that might arise with your Geo.

76 SERVICE CENTERS

Information on the location of your nearest Geo Service Center.

78 PARTS LIST

A table of components that make up the Geo.

WARRANTY CARD

Tear-out product registration card to be completed and returned. Alternatively register online at www.planeteclipse.com

83 SPARES & ACCESSORIES

Available upgrade / repair kits for your Geo.

QUICK GUIDE

CONTENTS

ORIENTATION

QUICK SET-UP

USING YOUR GEO

MENU TREE

ADVANCED SET-UP

MAINTENANCE

FAULT FINDING

SERVICE CENTERS

PARTS LIST

SPARES & ACCESSORIES

- A** EYE COVER SCREW
- B** EYE COVER
- C** SOLENOID ASSEMBLY
- D** PILOT VALVE
- E** CIRCUIT BOARD
- F** TRIGGER



ECLIPSE SHAFT 3 BARREL

NOTE: THE BORE SIZE OF YOUR SHAFT 3 MAY VARY ACCORDING TO THE MODEL OF GEO YOU HAVE.

Your Eclipse Geo comes as standard with a Eclipse Shaft 3 barrel.

The barrel screws into the body of the Geo using a right hand thread meaning that if you hold the Geo pointing away from you the barrel screws into the body in a counter-clockwise direction.

The barrel comprises of two parts, a barrel back **A** and a barrel front **B**. The two parts are joined together with the back nearest you, the front unscrews in a counter-clockwise direction. The bore size of the barrel back is engraved at the end of the barrel back **C**.

On the barrel back there is a #016 NBR70 o-ring **D** which prevents the barrel from vibrating loose from the Geo body when the marker is fired. There is also an o-ring on the barrel front **E** (#015 NBR70) helps with alignment between the barrel back and front.

Replace these o-rings as necessary.



NOTE: THE GEO WILL ONLY ACCEPT COCKER THREADED BARRELS. DO NOT USE ANY OTHER TYPE OF BARREL THREAD.

QUICK GUIDE

CONTENTS

ORIENTATION

QUICK SET-UP

USING YOUR GEO

MENU TREE

ADVANCED SET-UP

MAINTENANCE

FAULT FINDING

SERVICE CENTERS

PARTS LIST

SPARES & ACCESSORIES

INLINE REGULATOR

⚠ WARNING **WARNING: DO NOT REMOVE THE INLINE PURGE CONTROL VALVE.**
FAILURE TO COMPLY WITH THIS WARNING MAY CAUSE THE MARKER TO FIRE A SHOT THAT COULD RESULT IN SERIOUS INJURY OR DEATH.

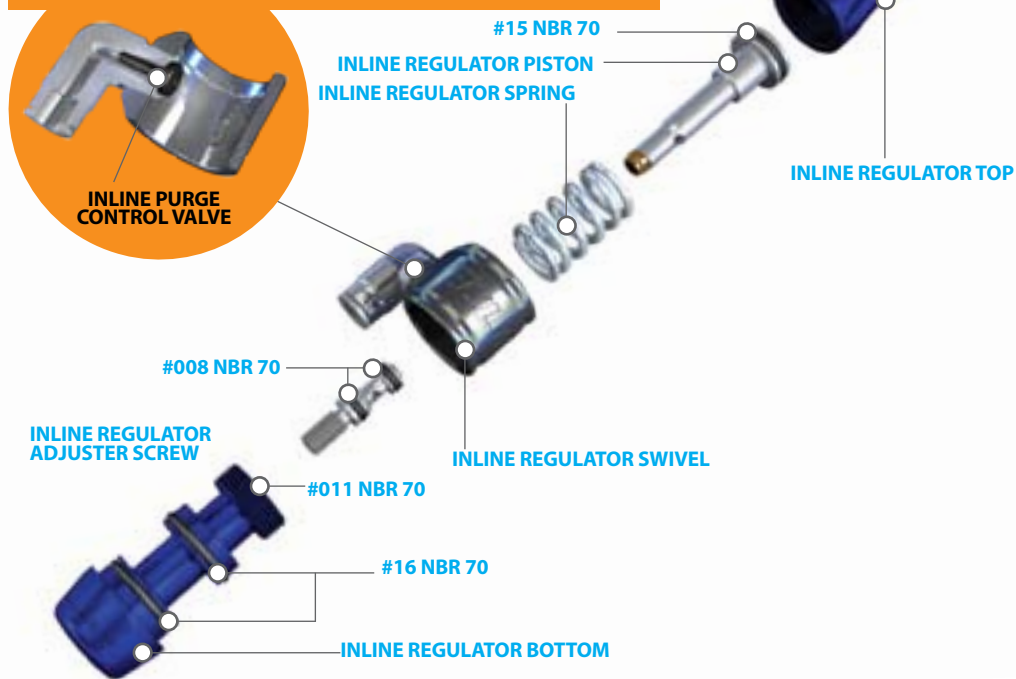

GEO BOLT SYSTEM

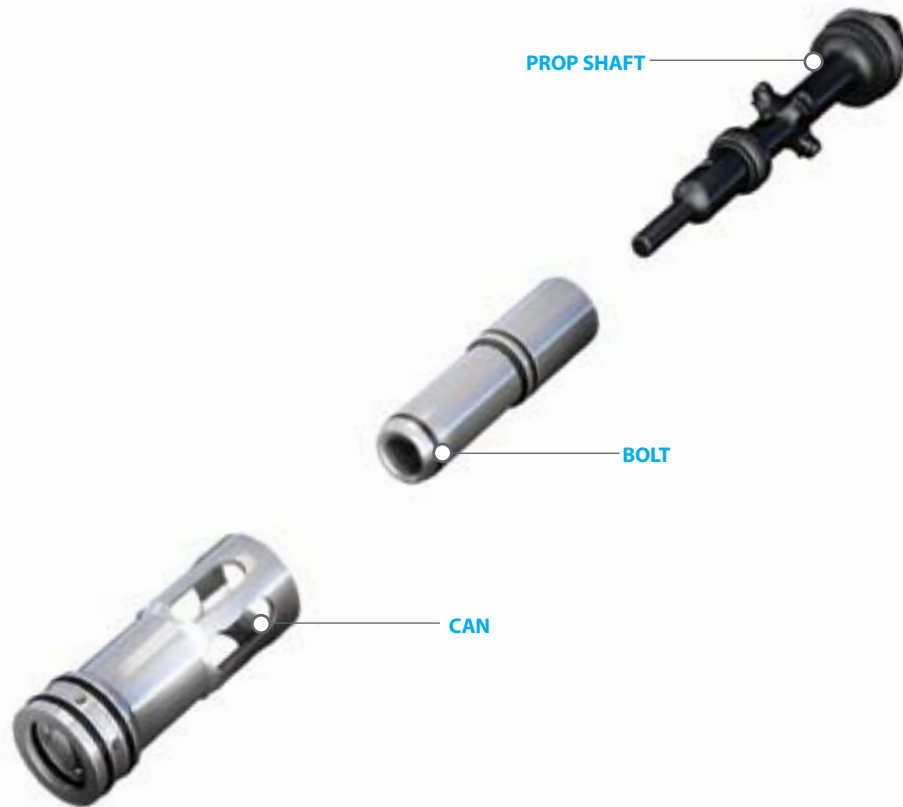

QUICK GUIDE

CONTENTS

ORIENTATION

QUICK SET-UP

USING YOUR GEO

MENU TREE

ADVANCED SET-UP

MAINTENANCE

FAULT FINDING

SERVICE CENTERS

PARTS LIST

SPARES & ACCESSORIES

SOLENOID ASSEMBLY

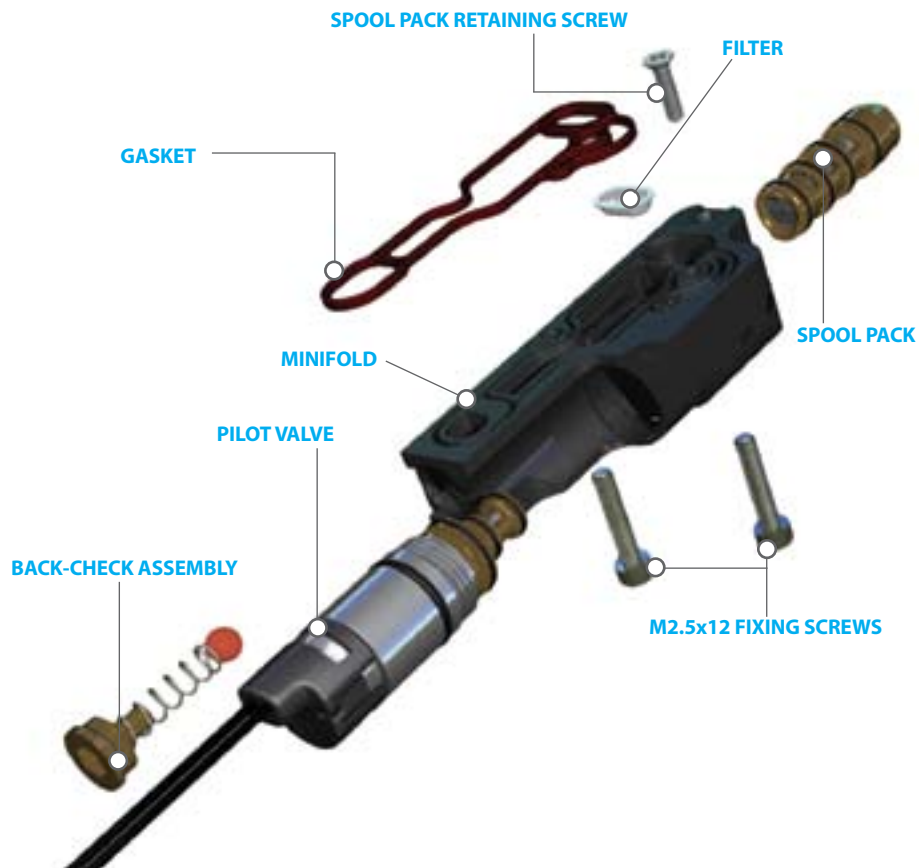

OPERATIONAL OVERVIEW

Below is a brief overview of what happens when you fire your Geo. The location of parts discussed in the text below can be found on page 78-79.

Assuming the Geo is gassed up and turned on **FIGURE 1.1** shows the marker in its idle position. The Firing Chamber is full of compressed air whilst the Bolt is held back by the air in the Can. Both the Firing Chamber and the Can are supplied with air via the Solenoid Valve.

Providing a ball is in the breach and the Trigger is pulled, a signal is sent to the Solenoid which stops the supply of air to the Firing Chamber and allows the air in the Can to be exhausted. This removes the force holding the Bolt in its rear position and the bolt is propelled forwards (**FIGURE 1.2**).

As the Bolt passes the Front Prop Shaft O-ring the Firing Chamber seal is broken and the air in the Firing Chamber vents down the Bolt, in turn propelling a ball. (**FIGURE 1.3**)

The length of time the Bolt remains in this forward position venting air from the Firing Chamber is dependant on Dwell. When the Solenoid has completed its Dwell time, air is routed back into the Can and pushes the Bolt back towards its rear position resealing the firing chamber. As the Firing Chamber is resealed it is re-filled through the Solenoid Valve to the operating pressure set by the user via the Inline Regulator (**FIGURE 1.4**).

The Geo has now completed one cycle and is ready to fire again.



FIG 1.1



FIG 1.2



FIG 1.3



FIG 1.4

QUICK GUIDE

CONTENTS

ORIENTATION

QUICK SET-UP

USING YOUR GEO

MENU TREE

ADVANCED SET-UP

MAINTENANCE

FAULT FINDING

SERVICE CENTERS

PARTS LIST

SPARES & ACCESSORIES

THE GEO NAVIGATION CONSOLE

At the rear of the Geo grip frame you will find the Navigation Console (FIGURE 1.5).

The Navigation Console is used for;

> **TURNING THE GEO ON AND OFF USING THE BUTTON** 

> **SCROLLING THROUGH MENUS WITH THE  AND  BUTTONS**

> **SELECTING PARAMETERS TO EDIT USING THE **

> **EDITING PARAMETERS USING THE  AND  BUTTONS**

> **TURNING THE GEO BBSS ON AND OFF USING THE  BUTTON**

> **RESETTING RECORDED VALUES USING THE **

> **CONTROLLING THE GAME TIMER WITH THE **



INSTALLING A 9V BATTERY

Ensure that the Geo is switched off. Lay the marker on a flat surface in front of you with the feed tube furthest away and with the barrel pointing to the right.

Use a 5/64" (2mm) hex wrench to remove the three countersunk screws that hold the rubber grip onto the frame. Peel the grip to the right to expose the circuit board within the frame.

Remove any fitted battery by sliding your thumb or finger into the recess below the battery and levering the battery out of the frame (SEE FIGURE 2.1).

DO NOT pull on the top of the battery to remove it as this can cause the battery terminals to bend and will result in a poor electrical connection.

Fit a 9-volt alkaline battery (type PP3, 6LR61 or MN1604) into the recess with the battery terminals away from you. The positive terminal should be on the right hand side, nearest to the side of the frame (SEE FIGURE 2.2).

Ensure that all of the wires are within the recess of the frame and away from the trigger micro-switch and opto sensors so as not to interfere with their operation and replace the rubber grip and replace the three countersunk screws.

DO NOT OVER-TIGHTEN THE SCREWS.

NOTE: BATTERY VOLTAGE MUST NOT EXCEED 10 VOLTS. SOME 9 VOLT RECHARGEABLE BATTERIES CAN EXCEED THIS VOLTAGE IF OVER CHARGED. IF IN DOUBT DO NOT USE RECHARGEABLE BATTERIES.



QUICK GUIDE

CONTENTS

ORIENTATION

QUICK SET-UP

USING YOUR GEO

MENU TREE

ADVANCED SET-UP

MAINTENANCE

FAULT FINDING

SERVICE CENTERS



PARTS LIST

SPARES & ACCESSORIES

SWITCHING ON THE GEO

To switch on the Geo press the  button twice in quick succession, referred to elsewhere in this manual as 'double-clicking'. The Geo can also be switched on by pushing and holding the  button (FIGURE 3.1).

SWITCHING OFF THE GEO

Press and hold the  button until the display shows **OFF?** Release the  button and re-press it to turn off the Geo. Alternatively when the display reads **OFF?**, you can pull the trigger once to turn off the Geo.

FIRING THE GEO

Pull the trigger to fire the Geo. The entire firing sequence is controlled electronically by the Geo circuit board, enabling any user to easily achieve high rates of fire.

THE GEO CIRCUIT BOARD

There are three sockets on the Geo Circuit board two of which are occupied by the BBSS Connector (A) and the Geo Solenoid (B). The third socket on the board (C) is the Auxiliary socket to which third party products such as loaders and RF transmitters can be connected using the relevant wiring harness (SEE FIGURE 3.2).

NOTE: WHEN THE GEO IS TURNED ON, THE AUXILIARY SOCKET IS AUTOMATICALLY SWITCHED ON AND CANNOT BE SWITCHED OFF



FIG 3.1

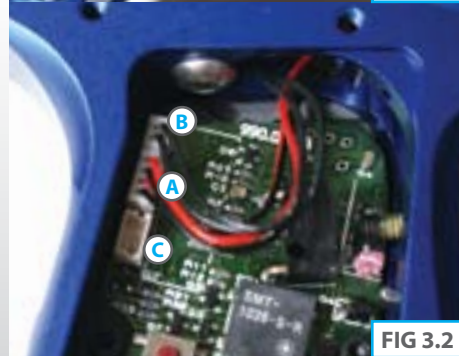





FIG 3.2



USING THE BREAK BEAM SENSOR SYSTEM

The Break Beam Sensor System is used to detect when a paintball is ready to fire from the Geo. If no paintball is ready then the BBSS will inhibit the Geo from firing. This prevents the Geo from 'chopping' paintballs that are not fully loaded into the marker.

To switch off the Break Beam Sensor System, press and hold the  button for 0.5 second (SEE FIGURE 3.3).

The break beam sensor system indicator on the top right of the LCD will change from  (enabled) to  (disabled).

To switch the Break Beam Sensor System back on, press and hold the  button for one second. The indicator will change back to .

When the Break Beam Sensor System is enabled, the indicator will change depending on if the system has detected a ball or not. When no ball has been detected the indicator looks like this  when a ball has been detected the icon changes to look like this .

Additional features of the Geo's Break Beam Sensor System are covered in full on page 24 of this user manual.

NOTE: WHEN THE GEO IS TURNED ON, THE BREAK BEAM SENSOR SYSTEM IS AUTOMATICALLY ENABLED



FIG 3.3

SETTING UP

Before you can begin to use your Geo, you will need to attach an air-system and a paintball loader.

NOTE: THE GEO CANNOT BE USED WITH CO₂, IT CAN ONLY BE POWERED BY COMPRESSED AIR OR NITROGEN.

INSTALLING A PRESET AIR SYSTEM

Every Geo comes complete with an Eclipse On/Off Purge System (OOPS) which provides a direct connection for a preset air system. Before screwing the air system into the OOPS ensure that the On/Off knob is wound out approximately half way (SEE FIGURE 4.1).

Be careful not to unscrew the On/Off knob too far as it will come completely off the OOPS. If this happens, replace the On/Off knob by screwing it back onto the OOPS body in a clockwise direction.

Screw the preset air system into the OOPS (SEE FIGURE 4.2) so that the bottle screws in all the way and is tight. Slowly turn the On/Off knob in a clockwise direction allowing the OOPS to depress the pin of the preset air system causing the Geo to become pressurised, providing that there is sufficient air in your tank (SEE FIGURE 4.3).

You have now installed a preset air system onto your Geo.

⚠ WARNING //

WARNING: ALWAYS RELIEVE ALL RESIDUAL GAS PRESSURE FROM THE GEO BEFORE UNSCREWING THE PRESET AIR SYSTEM.



FIG 4.1

FIG 4.2

FIG 4.3

T-SLOT MOUNTING SYSTEM

The Geo utilises a T-slot arrangement to mount the OOPS to the bottom of the frame. The T-slot is an improvement over the dovetail mounting system found on most paintball markers, and is much more able to withstand the rigours of modern tournament paintball.

For backwards compatibility there are industry standard mounting holes in the base of the frame for mounting third party air source adaptors (ASAs).



T-SLOT MOUNT

MACROLINE HOISING AND ELBOWS

To aid the longevity of your macroline hosing, it is very important to remove it from (and install it back into) the fittings in the correct manner:

Pull back the collet section of the macroline fitting and keep the collet depressed.

Pull the macroline hose out of the macroline fitting and release the collet.

Before installing the macroline hose into the macroline fitting ensure that the end has been trimmed correctly to ensure a tight fit in the fitting.



⚠ WARNING //

WARNING: IF YOU EVER REMOVE THE MACROLINE HOSE FROM THE FITTING, ALWAYS CHECK THE CONDITION OF YOUR MACROLINE HOISING AND IF IT IS WORN OR THE WRONG LENGTH REPLACE IT IMMEDIATELY.

QUICK GUIDE

CONTENTS

ORIENTATION

QUICK SET-UP

USING YOUR GEO

MENU TREE

ADVANCED SET-UP

MAINTENANCE

FAULT FINDING

SERVICE CENTERS

PARTS LIST

SPARES & ACCESSORIES

INSTALLING AN ADJUSTABLE AIR SYSTEM

Firstly disconnect the macroline hosing from the elbow attached to the OOPS at the base of the grip frame (SEE FIGURE 4.4).

Using a 3/32" hex key turn the two screws on the bottom of the OOPS in a counter clockwise direction so that the OOPS can be removed from the rail by sliding it backwards (SEE FIGURE 4.5).

As well as the integrated slide rail at the base of the Geo's grip frame, there are also two 10-32 UNF threaded screw holes which will accept all standard bottom line screws (SEE FIGURE 4.6).

Attach the air system of your choice, taking care to ensure that you use the correct length and size of hosing to accommodate your requirements.

⚠ WARNING ///

WARNING: BEFORE ATTACHING ANY FIXED AIR SYSTEM, PLACE ATTACHING SCREW IN DESIGNATED SLIDE RAIL AND MEASURE PROTRUDING SCREW LENGTH. SCREW LENGTH MUST NOT PROTRUDE MORE THAN 10MM/0.40" OTHERWISE THE GEO CIRCUIT BOARD WILL BECOME DAMAGED.



FIG 4.4



FIG 4.5



FIG 4.6

ATTACHING A LOADER

Using a 5/32" hex key, turn the top screw of the clamping feed neck counter clockwise (SEE FIGURE 5.1).

Release the clamping lever on the feed neck (SEE FIGURE 5.2) and test to see if your loader can easily be pushed into the top of the feed neck. If the loader cannot easily be pushed into the feed neck, loosen the top screw of the clamping feed neck a little more by turning it counter clockwise using a 5/32" hex key (SEE FIGURE 5.1).

When you have managed to push your loader into the clamping feed neck, close the clamp to secure it firmly in place (SEE FIGURE 5.3). If the loader is loose then you will need to release the clamp, tighten the screw slightly by turning it clockwise with a 5/32" hex key and closing the clamp. Repeat this process as necessary to secure your loader in place.

You have now attached a loader to your Geo. Once you have filled your loader and air tank you will then be ready to begin using your Geo.

⚠ WARNING ///

WARNING: DO NOT OVER TIGHTEN THE CLAMPING FEED NECK AS THIS MAY DAMAGE THE LOADER.



FIG 5.1



FIG 5.2



FIG 5.3

QUICK GUIDE

CONTENTS

ORIENTATION

QUICK SET-UP

USING YOUR GEO

MENU TREE

ADVANCED SET-UP

MAINTENANCE

FAULT FINDING

SERVICE CENTERS

PARTS LIST

SPARES & ACCESSORIES

SETTING THE TRIGGER

The Geo provides the user with the option to use either a Micro-Switch or an Opto Sensor as the means for detecting trigger pulls. Before you begin to adjust and set your trigger, you must first select the method of trigger detection that you wish to use by entering the Set-Up Menu and making your selection from the Hardware Menu (see page 52).

There are five adjustment points on the trigger – the **Front Stop Trigger Screw**, the **Rear Stop Trigger Screw**, the **Magnet Return Strength Screw**, the **Micro Switch Activation Screw** and the **Spring Return Strength Screw**.

As standard each Geo comes with a factory set trigger travel of approximately 2mm in total length; one millimeter of travel before the firing point and one millimeter of travel after the firing point, and the trigger detection method set to Opto.

The **Front Stop Trigger Screw** is used to set the amount of trigger travel prior to the marker firing. Turn this screw clockwise to reduce the amount of travel. Do not turn the screw too far or the trigger will be pushed past the firing point and the marker will not work. Turn this screw counter clockwise to increase the amount of trigger travel (SEE FIGURE 6.1).

The **Rear Stop Trigger Screw** is used to set the amount of travel after the marker has fired. Turn this screw clockwise to reduce the amount of travel. Do not turn the screw too far or the trigger will be prevented from reaching its firing point and the marker will not work. Turn this screw counter clockwise to increase the amount of travel (SEE FIGURE 6.2).

The **Magnet Return Strength Screw** is used to adjust the amount of force with which the trigger is returned to its rest position by the magnet. Turn the screw clockwise to increase the amount of force. Do not turn the screw too far or it will negate the position of the Front Stop Trigger Screw. Turn the screw counter clockwise to reduce the amount of force. Do not turn the screw too far or there will not be enough force to return the trigger (SEE FIGURE 6.3).

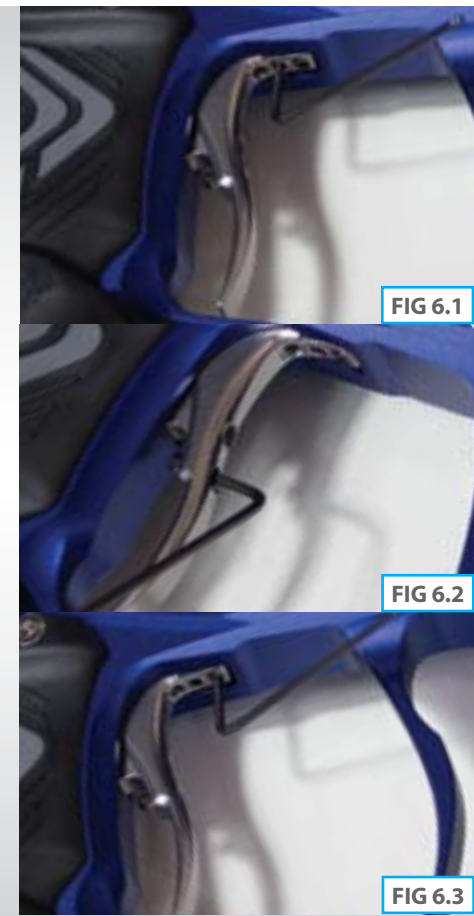

FIG 6.1

FIG 6.2

FIG 6.3

(CONTINUED)

The **Micro Switch Activation Screw** is used to adjust the point in the trigger pull at which the micro-switch is activated. Turn the screw clockwise to decrease the amount of trigger travel to the activation point. Turn the screw counter clockwise to increase the amount of trigger travel to the activation point (SEE FIGURE 6.4).

The **Spring Return Strength Screw** can only be adjusted by first removing the frame from the marker body, as per the instructions in the Maintenance section on page 61. The Spring Return Strength Screw is used to adjust the spring strength that returns the trigger to its resting position. Turn the screw clockwise to increase the amount of spring return strength in the trigger pull. Turn this screw counter clockwise to reduce the amount of spring return strength in the trigger pull. Do not turn the screw too far counter clockwise or there will not be enough force to return the trigger consistently (SEE FIGURE 6.5).



When setting the trigger it is important to ensure that the electronic trigger detection is working correctly. When the trigger is fully depressed the Trigger Detection Indicator (TDI) should point upwards . When the trigger is fully released the TDI should point downwards . For more information, see Understanding the Trigger Detection Indicator (TDI) on page 25 and The Filter Menu on page 46.

FIGURE 6.6 KEY

- A Spring
- B Spring Return Strength Screw
- C Trigger Pin Locking Screw
- D Front Stop Trigger Screw
- E Magnet Return Strength Screw
- F Micro Switch Activation Screw
- G Rear Stop Trigger Screw

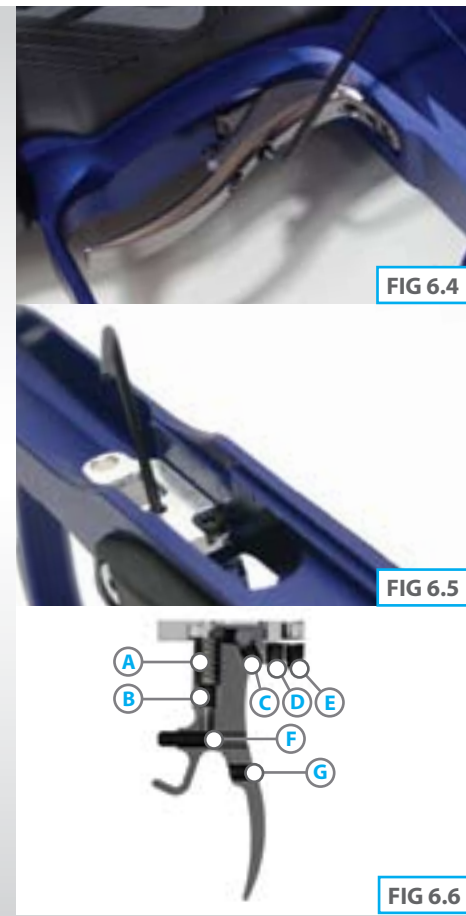

FIG 6.4

FIG 6.5

FIG 6.6

QUICK GUIDE

CONTENTS

ORIENTATION

QUICK SET-UP

USING YOUR GEO

MENU TREE

ADVANCED SET-UP

MAINTENANCE

FAULT FINDING

SERVICE CENTERS

PARTS LIST

SPARES & ACCESSORIES

ADJUSTING THE VELOCITY

When using your Geo, you may wish to change the velocity at which your Geo is firing. This is done by inserting a 1/8" hex key into the adjuster screw at the bottom of your Geo Inline Regulator and adjusting it accordingly (SEE FIGURE 7.1). By turning this adjuster screw clockwise you decrease the output pressure of the Inline Regulator and consequently the velocity, by turning the adjuster screw counter clockwise you increase the output pressure of the Inline Regulator and consequently the velocity.

NOTE: AFTER EACH ADJUSTMENT FIRE TWO CLEARING SHOTS TO GAIN AN ACCURATE VELOCITY READING. NEVER EXCEED 300FPS.

ADJUSTING THE FIRING CHAMBER VOLUME

When using your Geo you may wish to change the volume of your Firing Chamber using the Prop Shaft Adjuster Screw located in the rear of the Prop Shaft (SEE FIGURE 7.2).

This is easily done by inserting a 1/8" hex key into the Prop Shaft Adjuster Screw and adjusting it accordingly.

By turning the Prop Shaft Adjuster Screw clockwise you decrease the volume of the Firing Chamber and consequently you will need to increase the output pressure from your Inline Regulator to achieve velocities similar to the ones you had prior to adjusting the Prop Shaft Adjuster Screw. By turning the Prop Shaft Adjuster Screw counter clockwise you increase the volume of the Firing Chamber and consequently you will need to decrease the output pressure from your Inline Regulator to achieve velocities similar to the ones you had prior to adjusting the Prop Shaft Adjuster Screw.

NOTE: AFTER EACH ADJUSTMENT FIRE TWO CLEARING SHOTS TO GAIN AN ACCURATE VELOCITY READING. NEVER EXCEED 300FPS.



FIG 7.1





FIG 7.2

USER INTERFACE

The Geo has a simple user interface through which all aspects of its electronic control system can be monitored and adjusted by means of the three pushbuttons and graphical LCD which comprise the Navigation Console.

SWITCHING ON

To switch on the Geo press the  button twice in quick succession, referred to elsewhere in this manual as 'double-clicking'. The Geo can also be switched on by pushing and holding the  button. The LCD will display startup information including model number and software version before displaying the Run Screen. To skip the startup information simply press the  button.

RUN SCREEN LAYOUT

The root of the user interface is the Run Screen. This screen is the one most often displayed and provides the user with essential feedback on the state of the Geo. A typical Run Screen is shown on the right. On the left of the screen is a display option that is user selectable from the Main Menu (see page 33). This option can be:-

- > A GAME TIMER
- > A SHOT COUNTER
- > AN AVERAGE RATE OF FIRE INDICATOR
- > A PEAK RATE OF FIRE INDICATOR

Briefly pressing the  button will replace the display option with the name of the currently selected Preset (see page 37), or CUSTOM if a parameter of the selected preset mode has been edited.

On the right of the screen are up to five icons, each of which provides graphical indication on different parts of the Geo control electronics.

BREAK BEAM SENSOR SYSTEM INDICATOR

SOUND INDICATOR

TRIGGER DETECTION INDICATOR

USER SELECTABLE DISPLAY OPTION

LOCK INDICATOR

BATTERY LEVEL INDICATOR



QUICK GUIDE

CONTENTS

ORIENTATION

QUICK SET-UP

USING YOUR GEO

MENU TREE

ADVANCED SET-UP

MAINTENANCE

FAULT FINDING

SERVICE CENTERS

PARTS LIST

SPARES & ACCESSORIES

UNDERSTANDING THE BBSS INDICATOR (BBSS)

The BBSS is able to switch itself off in the event that a blockage or contamination prevents it from functioning correctly. In this instance, the BBSS will switch itself back on once the blockage is cleared and the correct operation can be resumed.

The BBSS Indicator on the main screen is used to indicate the eight possible states of the BBSS as follows:



BBSS ENABLED AND BALL DETECTED
The Geo can be fired at the maximum rate of fire determined by the chosen firing mode.



BBSS ENABLED NO BALL DETECTED
The Geo cannot be fired.



BBSS DISABLED
The Geo can be fired at a maximum rate of fire as set by the **OFF ROF** parameter (see page 40)



BBSS FAULT DETECTED
The system is disabled. The Geo can only be fired at a maximum rate of fire of 10bps, regardless of the chosen firing mode.



BBSS SENSOR FAULT HAS BEEN CLEARED
The sensor has been re-enabled. A ball is detected and the Geo can be fired at the maximum rate of fire determined by the chosen firing mode.



BBSS FAULT HAS BEEN CLEARED
The sensor is enabled. No ball is detected so the Geo cannot be fired. To reset the BBSS icon, use the **▲** button to switch off the BBSS and then back on again.



BBSS ENABLED IN TRAINING MODE
The BBSS has been over-riden as the user has selected training mode. As the user has chosen to leave the BBSS on, the achievable rate of fire is limited by the firing mode.



BBSS DISABLED IN TRAINING MODE
The BBSS has been over-riden as the user has selected training mode. As the user has chosen to turn the BBSS off, the achievable rate of fire is limited by the **OFF ROF** parameter (see page 40).

UNDERSTANDING THE SOUND INDICATOR

The **SOUND** Indicator on the main screen is used to convey if the **SOUND** parameter in the Hardware menu (page 52) is switched on or off.

There are two possible conditions that can be indicated:



SOUND ENABLED
The **SOUND** parameter is enabled. The Geo will make sounds when switched on and off and when the game timer alarms or times out.



SOUND DISABLED
The **SOUND** parameter is disabled. The Geo will not make any sounds.

UNDERSTANDING THE TRIGGER DETECTION INDICATOR (TDI)

In order for the trigger to be successfully operated it must first be released and then pulled. The Trigger Detection Indicator (TDI) is used to indicate each of the possible trigger states.



OPTO SENSOR SELECTED, READING 0%
The Geo is configured to use the opto sensor to detect trigger pulls. The opto sensor is currently reading 0%, i.e. the trigger is fully released.



OPTO SENSOR SELECTED, READING BELOW RELEASE POINT
The Geo is configured to use the opto sensor to detect trigger pulls. The opto sensor is currently reading below the Opto Release Point, i.e. the trigger is considered 'released'.



OPTO SENSOR SELECTED, READING MIDRANGE
The Geo is configured to use the opto sensor to detect trigger pulls. The opto sensor is currently reading somewhere between the Opto Release Point and the Opto Pull Point, i.e. the trigger is half depressed.



OPTO SENSOR SELECTED, READING ABOVE PULL POINT
The Geo is configured to use the opto sensor to detect trigger pulls. The opto sensor is currently reading above the Opto Pull Point, i.e. the trigger is considered 'pulled'.



OPTO SENSOR SELECTED, READING 100%
The Geo is configured to use the opto sensor to detect trigger pulls. The opto sensor is currently reading 100%, i.e. the trigger is fully depressed.



MICRO-SWITCH SELECTED, NOT ACTUATED
The Geo is configured to use the micro-switch to detect trigger pulls. The micro-switch is not currently actuated, i.e. the trigger is released.



MICRO-SWITCH SELECTED, ACTUATED
The Geo is configured to use the micro-switch to detect trigger pulls. The micro-switch is currently actuated, i.e. the trigger is pulled.

From the factory the Geo will have the opto sensor enabled. The micro-switch option can be selected by referring to the Hardware Menu (see page 52).

QUICK GUIDE

CONTENTS

ORIENTATION

QUICK SET-UP

USING YOUR GEO

MENU TREE

ADVANCED SET-UP

MAINTENANCE

FAULT FINDING

SERVICE CENTERS

PARTS LIST

SPARES & ACCESSORIES

UNDERSTANDING THE LOCK INDICATOR

The Geo has a tournament lock which prevents the user from making changes to any parameter that affects the way in which the Geo shoots, without the need for tools. This feature is necessary in order to make the Geo legal for tournament play.

When the lock is enabled the lock indicator will show a closed padlock .

When the lock is disabled the lock indicator will show an open padlock .

UNDERSTANDING THE BATTERY LEVEL INDICATOR

The battery level indicator is used to show the state of the battery within the Geo. When the battery is fresh the indicator will show a 'full' battery , and as the battery is drained, so the indicator will show the battery emptying. When the battery reaches a point at which the Geo will no longer function reliably, the indicator will start to flash. At this point the battery must be changed immediately.

THE GAME TIMER

When the Game Timer is shown on the Run Screen then it can be started by pressing the  button and the timer will start to count down. The Game Timer can also be configured to start on a trigger press with the **START** parameter (see page 35).

When the Game Timer reaches the **ALARM** time the Game Timer will start to flash and the audible alarm will sound every second, provided that the **SOUND** parameter is on.

When the Game Timer reaches 00:00, **GAME OVER** will be displayed and the audible alarm will sound continually, provided that the **SOUND** parameter is set to 'ON'.

To stop the Game Timer at any time press and hold the  button for 0.5 seconds.

To reset the Game Timer to its preset start time, push and hold the  button for 1 second. The Game Timer will also be reset whenever the Geo is switched off.

THE SHOT COUNTER

The Shot Counter increments every time that the Geo is fired, regardless of whether the Shot Counter is displayed or not. When the Shot Counter is displayed on the Run Screen it can be reset to 0 by pressing and holding the  button for 0.5 seconds.

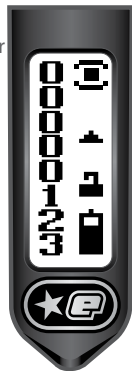
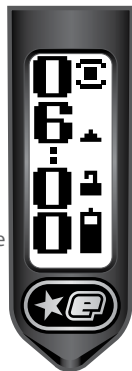

THE AVERAGE RATE OF FIRE

When the Average ROF is selected for display the Run Screen will look something like the screen to the right. The value displayed in the top left of the screen represents the number of full cycles completed in the last second - the average rate of fire over the second. The number below it is the maximum average rate of fire that has been recorded. To reset this maximum, press and hold the  button for 0.5 seconds.

THE PEAK RATE OF FIRE

When the Peak ROF is selected for display the Run Screen will look something like the screen to the left, which differs from the display of the Average ROF by the inclusion of the indicator 'PK'. The value displayed in the top left of the screen represents the rate of fire measured between the last two shots. The number below it is the maximum peak rate of fire that has been recorded. To reset this maximum, press and hold the  button for 0.5 seconds.

The Peak ROF is typically higher than the Average ROF as it is much easier to fire two shots in quick succession than it is to maintain a string over a longer period of time.



THE MENU SYSTEM

Behind the Run Screen is a structured menu system comprised of multiple levels of menus. Each menu contains a number of menu items and each menu item can either be an editable parameter or a branch to another menu. Branches always have an animated graphic whereas parameters indicate their current value.

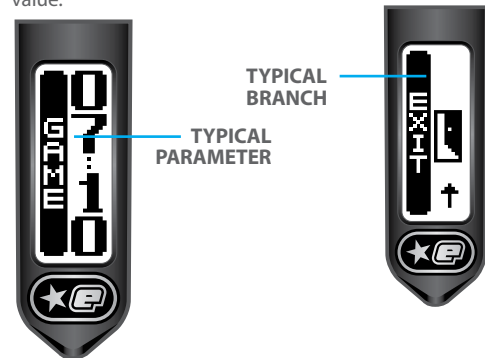

The menu structure is shown in the following pages.

The menus are 'smart menus' in that they will expand and contract depending upon the state of certain parameters. For example, the **MAX ROF** parameter is only visible when the **ROF CAP** parameter is set to 'on'. Smart menu items are indicated with a * in the table below.

QUICK GUIDE

CONTENTS

ORIENTATION

QUICK SET-UP

USING YOUR GEO

MENU TREE

ADVANCED SET-UP

MAINTENANCE

FAULT FINDING

SERVICE CENTERS

PARTS LIST

SPARES & ACCESSORIES

MAIN MENU

MAIN MENU

| | | |
|---------|---|---|
| OFF? | | Turn off the Geo |
| DISPLAY | Timer Shots Avg ROF Peak ROF Cancel | Display the game timer on the Run Screen Display the shot counter on the Run Screen Display the average rate of fire on the Run Screen Display the peak rate of fire on the Run Screen Cancel the display selection |
| TIMER | | |
| GAME | 00:00 - 60:00 | Countdown game timer start time |
| ALARM | 00:00 - 10:00 | Alarm activation time |
| START | Button Trigger Cancel | Button starts the game timer Trigger pull starts the game timer Cancel game timer start event selection |
| BACK | | Go back one menu level |
| EXIT | | Return to the Run Screen |

Parameters followed by a * are part of the smart menu system and will only be displayed depending on your chosen settings. (E.g. The MAX ROF parameter will only become available if the ROF CAP parameter is set to on).

SET-UP MENU

SET-UP MENU

| | | |
|----------|--|---|
| LOCK | Off On Cancel | Turn the tournament lock off Turn the tournament lock on Make no changes to the tournament lock |
| PRESET | | |
| LOAD | User 1 User 2 Factory NPPL PSP 08 MS 08 Cancel | Load the User 1 settings Load the User 2 settings Load the default factory settings (semi-automatic) Load NPPL compliant settings Load the PSP 2008 compliant settings Load Millennium Series 2008 compliant settings Cancel the load operation |
| SAVE | User 1 User 2 Cancel | Save the current settings as the User 1 settings Save the current settings as the User 2 settings Cancel the save operation |
| BACK | | Go back one menu level |
| MODE | Semi Ramp Cancel | Select semi-automatic mode of fire Select ramping mode of fire Cancel the mode selection |
| ROF CAP | Off On Cancel | Turn off the rate of fire cap Turn on the rate of fire cap Cancel the ROF cap selection |
| MAX ROF* | 10.0 - 22.0 | Rate of fire cap in balls per second when BBSS is enabled |
| OFF ROF | 4.0 - 15.0 | Rate of fire cap in balls per second when BBSS is disabled |

QUICK GUIDE

CONTENTS

ORIENTATION

QUICK SET-UP

USING YOUR GEO

MENU TREE

ADVANCED SET-UP

MAINTENANCE

FAULT FINDING

SERVICE CENTERS

PARTS LIST

SPARES & ACCESSORIES

SET-UP MENU

| RAMP SET* | | |
|-----------|--------------------------|--|
| TYPE | Step Linear Cancel | Select step type ramping Select linear type ramping Cancel the ramp type selection |
| RATE | 0 - 100 | Percentage linear ramp rate |
| PULL NO | 4 - 9 | Number of shots before ramping can start |
| KICK IN | 5.0 - 15.0 | Rate at which trigger has to be pulled in pulls per second before ramping can start |
| SUSTAIN | 5.0 - 15.0 | Rate at which trigger has to be pulled in pulls per second in order to maintain ramping |
| RESTART | 0.0 - 1.0 | Time in seconds after last trigger pull during which ramp can be restarted |
| BACK | | Go back one menu level |
| TIMING | | |
| DWELL | 0.0 - 25.0 | Solenoid energise time in milliseconds for each shot |
| FSD COMP | 0.0 - 3.0 | First shot drop-off compensation time in milliseconds |
| FSD DLY | 30 - 240 | Delay in seconds before 'First Shot Drop Off Compensation' is applied |
| LIGHT | 0.0 - 20.0 | Backlight off delay in seconds |
| SLEEP | 5 - 60 | Auto power off time in minutes |
| BACK | | Go back one menu level |
| FILTER | | |
| DBOUNCE | Level 9 | Use trigger debounce level 9 (less bounce) |
| | Level 1 Cancel | Use trigger debounce level 1 (more bounce) Cancel debounce selection |
| EMPTY | 1.0 - 10.0 | Time in milliseconds that the breech must remain empty before the BBSS can look for a paintball. |

SET-UP MENU

| FULL | 1.0 - 20.0 | Time in milliseconds that a paintball must be in the breech for the Geo to be ready to fire |
|----------|--------------------------|--|
| PULL TM | 3.0 - 25.0 | Time in milliseconds that the trigger must be pulled in order for a shot to be fired |
| REL TM | 3.0 - 25.0 | Time in milliseconds the trigger must be released prior to being pulled |
| PULL PT* | 51 - 99 | When using the opto trigger sensor, point at which the trigger is considered pulled |
| REL PT* | 1 - 49 | When using the opto trigger sensor, point at which the trigger is considered released |
| BACK | | Go back one menu level |
| TRAININ | Off On Cancel | Training mode disabled Training mode enabled Cancel training mode selection |
| HARDWRE | | |
| TRIGGER | Opto Switch Cancel | Use opto sensor to detect trigger operation Use micro-switch to detect trigger operation Cancel trigger detection method selection |
| SOUND | Off On Cancel | Turn off audible indicator Turn on audible indicator Cancel audible indicator selection |
| TONES* | Off On Cancel | Turn off audible tone when any button is pressed Turn on audible tone when any button is pressed Cancel audible tone selection |
| BACK | | Go back one menu level |
| EXIT | | Return to the Run Screen |

QUICK GUIDE

CONTENTS

ORIENTATION

QUICK SET-UP

USING YOUR GEO

MENU TREE

ADVANCED SET-UP

MAINTENANCE

FAULT FINDING

SERVICE CENTERS

PARTS LIST

SPARES & ACCESSORIES

ACCESSING THE MENU SYSTEM

To access the Main Menu from the Run Screen double-click the button and the first item on the Main Menu will be displayed. Alternatively, push and hold the button for 2 seconds.

To access the Set-up Menu from either the Run Screen or the Main Menu double-click the internal button and the first item on the Set-up Menu will be displayed. Alternatively, push and hold the internal pushbutton for 2 seconds.

NOTE: IF THE TOURNAMENT LOCK IS SET TO 'OFF' THEN THE MAIN MENU AND SET-UP MENU ARE JOINED TOGETHER WHICH MEANS THAT THEY CAN BE ACCESSED IN EITHER OF THE TWO WAYS ABOVE.

MOVING AROUND THE MENUS

Press and release the button to display the next item on the menu. When the last menu item is displayed, pressing the button will display the first item.

Press and release the button to display the previous item on the menu. When the first menu item is displayed, pressing the button will display the last item.

When the displayed item is a branch, as indicated by an animation on the right of the screen, press the button to move to another menu.

ALTERING PARAMETERS

When the displayed item is a parameter, as indicated by a parameter value on the right of the screen, pressing the button will activate the EDIT mode which allows the parameter value to be altered. When EDIT mode is active, edit indicators appear on the left of the screen as shown in the screen below.

EDIT INDICATORS

There are two types of parameter, numeric parameters and choice parameters. A numeric parameter has a value which is a number whereas a choice parameter is one that has a small number of distinct choices. Altering parameter values is essentially the same for both types of parameter.

To alter a numeric parameter, first activate the EDIT mode. Press the button to increase the parameter value one step at a time. Press and hold the button to increase the parameter value rapidly. When the value reaches its maximum it will revert to its minimum value. Press the button to decrease the parameter value one step at a time. Press and hold the button to decrease the parameter value rapidly. When the value reaches its minimum it will revert to its maximum value. When the required parameter value is displayed press the button to accept the value and end the EDIT mode.

To alter a choice parameter, first activate the EDIT mode. Press the button to display the next choice in the list. When the last choice is displayed, pressing will display the first choice in the list. Press the button to display the previous choice in the list. When the first choice is displayed, pressing the button will display the last choice in the list. When the required choice is displayed press the button to accept the choice and end the EDIT mode. If the displayed choice is Cancel then pressing the button will end the EDIT mode and restore the parameter to the value that was prior to editing.



THE MAIN MENU

The Main Menu comprises parameters that do not affect the way in which the Geo shoots and which therefore do not have to be tournament locked.

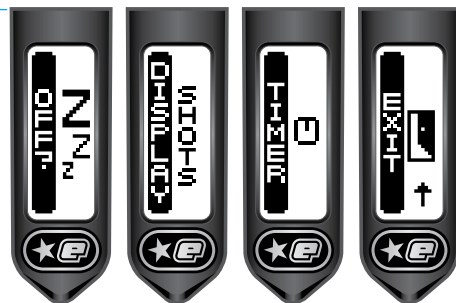

To turn off the Geo, select the **OFF?** branch or pull the trigger while the **OFF?** branch is displayed.

To return to the Run Screen, select the **EXIT** branch.

NOTE: IF THE LOCK OPTION IS DISABLED FURTHER OPTIONS WILL BE DISPLAYED IN THE MAIN MENU.

DISPLAY

THE DISPLAY PARAMETER

This parameter is used to select the information that is displayed on the left of the Run Screen. This parameter has the following choices:-

- > **TIMER:** The Game Timer is displayed on the Run Screen
- > **SHOTS:** The Shot Counter is displayed on the Run Screen
- > **AVG ROF:** The Average Rate of Fire is displayed on the Run Screen
- > **PEAK ROF:** The Peak Rate of Fire is displayed on the Run Screen
- > **CANCEL:** Editing is cancelled and the parameter remains unchanged.

This parameter differs from most others in that once a choice has been made then the EDIT mode is ended and the display returns to the Run Screen.



QUICK GUIDE

CONTENTS

ORIENTATION

QUICK SET-UP

USING YOUR GEO

MENU TREE

ADVANCED SET-UP

MAINTENANCE

FAULT FINDING

SERVICE CENTERS

PARTS LIST

SPARES & ACCESSORIES

TIMER

THE GAME TIMER MENU

This menu is comprised of parameters that control the operation of the Game Timer:

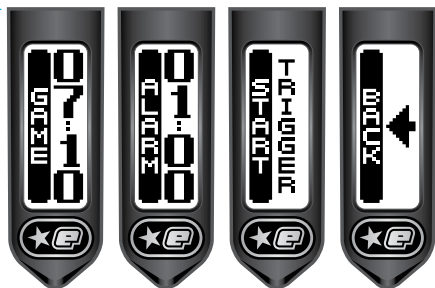
**GAME**

THE GAME TIME PARAMETER

This parameter is used to set the game time; the time from which the Game Timer counts down to zero. This parameter can be set between 00:00 and 60:00 minutes in 10 second increments and the factory default is 07:10 (7 minutes 10 seconds).

When the game timer reaches 00:00, GAME OVER will be displayed and the audible alarm will sound continually, that the **SOUND** parameter is set to 'ON'.

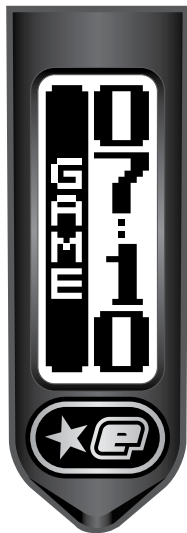
**ALARM**

THE ALARM TIME PARAMETER

An alarm condition is generated whenever the Game Timer counts down to a specific time set by the **ALARM** parameter. This parameter can be set between 00:00 and 10:00 minutes in 10 second increments.

When the alarm condition is generated the Game Timer will start to flash and the audible alarm will sound every second, provided that the **SOUND** parameter is set to 'ON'.

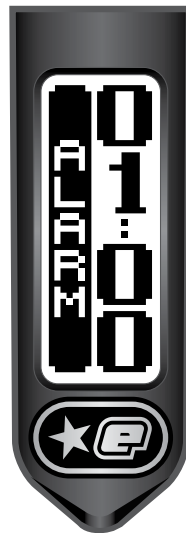
**START**

THE TIMER START PARAMETER

This parameter is used to select the event which will cause the Game Timer to begin counting down. This parameter has the following choices:

- > **BUTTON:** Pressing the **Y** button will start the game timer.
- > **TRIGGER:** Pulling the trigger will start the game timer.
- > **CANCEL:** Cancel editing and leave the parameter unchanged.

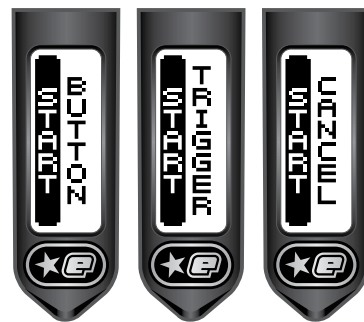
**QUICK GUIDE**

CONTENTS

ORIENTATION

QUICK SET-UP

USING YOUR GEO

MENU TREE

ADVANCED SET-UP

MAINTENANCE

FAULT FINDING

SERVICE CENTERS

PARTS LIST

SPARES & ACCESSORIES

THE SETUP MENU

This menu is the starting point for access to all of the parameters that control the way that the Geo operates. To access this menu, first turn on the Geo and then remove the 3 screws holding the right hand cheek of the rubber grips (SEE FIGURE 8.1). Peeling back the cheek will reveal a red Setup button (A) on the circuit board (SEE FIGURE 8.2), double-click this button or, alternatively, push and hold it for 2 seconds.

If the tournament lock (LOCK) is off then this menu is joined to the end of the Main Menu and can therefore be accessed without tools.



FIG 8.1



FIG 8.2

LOCK THE TOURNAMENT LOCK PARAMETER

The Geo has a tournament lock which prevents the user from making changes to any parameter that affects the way in which the Geo shoots without the use of tools.

This parameter is used to set the state of the tournament lock and has the following choices:-

- > **ON:** Turn on the tournament lock. The Set-Up Menu is added to the Main Menu, making it easily accessible by pressing and holding the button.
- > **OFF:** Turn off the tournament lock. The Set-Up Menu is only accessible by removing the right hand cheek of the rubber grips and then pressing and holding the red **SETUP** button on the circuit board.
- > **CANCEL:** Cancel selection and leave the parameter unchanged.

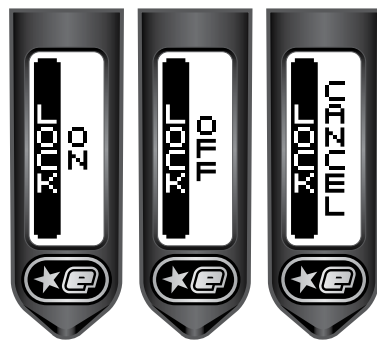

PRESET THE PRESET MENU

In order to simplify the set up of the Geo a number of Preset configurations are available for selection. Choosing one of these presets will cause all of the necessary parameters to be set in such a way as to make the Geo comply with the rules governing a particular paintball league. It is also possible for the user to save up to two Preset configurations of their own.

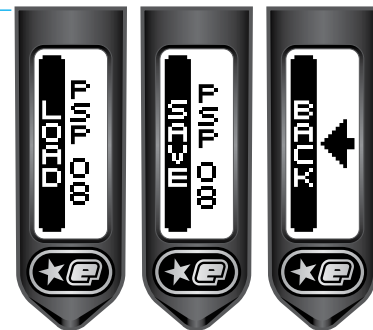

LOAD THE LOAD PRESET PARAMETER

This parameter is used to load the required Preset configuration and has the following choices.

- > **FACTORY:** Reset every parameter to the factory set defaults. The Geo leaves the factory set in this way and this is also described on the Run Screen as SEMI.
- > **NPPL:** Load a set of parameters that configures the Geo to comply with the 2008 NPPL rules governing firing modes.
- > **PSP 08:** Load a set of parameters that configures the Geo to comply with the 2008 PSP rules governing firing modes.

QUICK GUIDE

CONTENTS

ORIENTATION

QUICK SET-UP

USING YOUR GEO

MENU TREE

ADVANCED SET-UP

MAINTENANCE

FAULT FINDING

SERVICE CENTERS

PARTS LIST

SPARES & ACCESSORIES

LOAD

THE LOAD PRESET PARAMETER (CONT.)

> **MS 08:** Load a set of parameters that configures the Geo to comply with the 2008 Millennium Series rules governing firing modes.

> **CANCEL:** Editing is cancelled and the parameter remains unchanged.

> **USER 1:** Load a set of custom firing mode parameters that have been previously saved by the user.

> **USER 2:** Load a second set of custom firing mode parameters that have been previously saved by the user.

With the exception of **FACTORY** each of the Presets changes only those parameters that control the firing mode of the Geo, leaving **FILTER**, **TIMING** and **HARDWARE** parameters unchanged.

NOTE: THE MAX ROF IN BOTH THE FACTORY AND NPPL PRESETS IS CAPPED AT 22 BPS TO OPTIMISE THE PERFORMANCE OF THE GEO. THIS CAN BE UNCAPPED BY CHANGING THE ROF CAP TO OFF IN THE SET-UP MENU.

SAVE

THE SAVE PRESET PARAMETER

This parameter is used to save the current set of parameters as a user defined custom Preset configuration. This parameter has the following choices:-

> **USER 1:** Save the current parameters as the preset 'USER 1'.

> **USER 2:** Save the current parameters as the preset 'USER 2'.

> **CANCEL:** Editing is cancelled and the parameter remains unchanged.



NOTE: THE CURRENT PRESET CONFIGURATION CAN BE VIEWED FROM THE RUN SCREEN BY PRESSING THE BUTTON.

MODE

THE FIRING MODE PARAMETER

This parameter is used to select the firing mode of the Geo and has the following choices:

> **SEMI:** This is the default and in this firing mode the Geo will fire one shot for every trigger pull.

> **RAMP:** In this firing mode, the rate of fire is increased above the rate at which the trigger is pulled once certain criteria have been met. These criteria are set by the parameters on the Ramp Set Menu.

> **CANCEL:** Editing is cancelled and the parameter is unchanged.

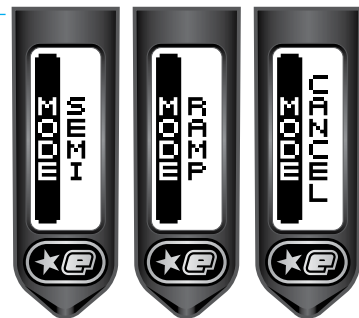

PLEASE NOTE: CERTAIN MODES MAY ONLY BE AVAILABLE IN CERTAIN COUNTRIES AND ON CERTAIN MODELS OF THE GEO.

ROF CAP

THE RATE OF FIRE CAP PARAMETER

The **ROF CAP** parameter is used to specify whether or not the Geo should have a limited, or capped rate of fire. When the **ROF CAP** is enabled, the maximum achievable rate of fire is set by the **MAX ROF** parameter. Choices for the **ROF CAP** parameter are:-

> **OFF:** Rate of Fire only limited by the loader.

> **ON:** Rate of Fire limited to the **MAX ROF** parameter value.

> **CANCEL:** Cancel editing and leave the parameter unchanged.

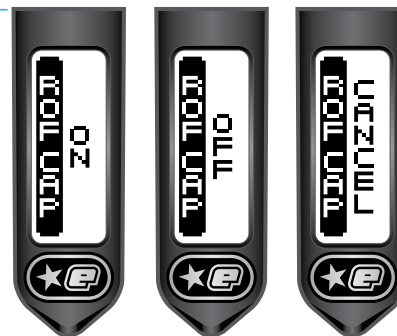

If the **ROF CAP** is switched on, then the **MAX ROF** parameter will feature as an item in the Set-Up Menu. If the **ROF CAP** is switched off, the **MAX ROF** parameter is redundant and omitted from the Set-Up Menu.

PLEASE NOTE: SWITCHING THE ROF CAP TO "OFF" MAY CAUSE DROP OFF IF SHOOTING AT EXCESSIVE SPEEDS.

MAX ROF

THE MAXIMUM RATE OF FIRE PARAMETER

The **MAX ROF** parameter is used to set the maximum achievable rate of fire from the Geo. The value of this parameter can be adjusted between 10.0 and 22.0 balls per second in 0.1bps increments.

The **MAX ROF** parameter will only be displayed if you have set the **ROF CAP** parameter to 'ON'.

NOTE: FOLLOWING EXTENSIVE TESTING, THE GEO MAX ROF PARAMETER HAS BEEN LIMITED TO 22.0 BALLS PER SECOND FOR OPTIMUM LEVELS OF PERFORMANCE AND RELIABILITY.

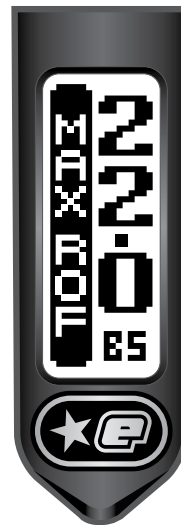

QUICK GUIDE

CONTENTS

ORIENTATION

QUICK SET-UP

USING YOUR GEO

MENU TREE

ADVANCED SET-UP

MAINTENANCE

FAULT FINDING

SERVICE CENTERS

PARTS LIST

SPARES & ACCESSORIES

OFF ROF

THE RATE OF FIRE WHEN BBSS OFF PARAMETER

The **OFF ROF** parameter is used to control how fast the Geo cycles when the Break Beam Sensor System is disabled. This parameter can be set between 4.0 and 15.0 balls per second and should always be set to the slowest speed of the loading system in use.

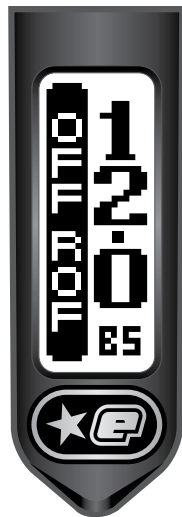

RMP SET

THE RAMP SETTINGS MENU

This menu is only available when ramping has been selected with the **MODE** parameter and comprises a list of parameters that control the way in which the Geo ramps, as shown below:

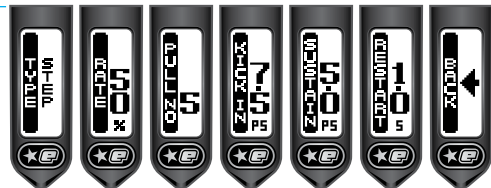

TYPE

THE RAMP TYPE PARAMETER

This parameter is used to select the ramping style and has the following choices:-

> **STEP:** Step ramping will cause the Geo to shoot in semi-automatic until a number of trigger pulls, set by **PULL NO**, have been made at a minimum pull rate, set by **KICK IN**. At this point the rate of fire will step up to the maximum rate of fire as set by **MAX ROF** (or the maximum loader speed if the **ROF CAP** parameter is set to off). Ramping is maintained as long as the user continues to pull the trigger at a required rate set by **SUSTAIN**.

> **LINEAR:** Linear ramping will cause the Geo to shoot in semi-automatic until a number of trigger pulls, set by **PULL NO**, have been made at a minimum pull rate, set by **KICK IN**. At this point the rate of fire will equal the rate of trigger pulls increased by the percentage specified by **RATE** up to a maximum rate of fire as set by **MAX ROF**, if the **ROF CAP** is on. Ramping is maintained as long as the user continues to pull the trigger at a required rate set by **SUSTAIN**.

> **CANCEL:** Editing is cancelled and no changes are made to the parameter.

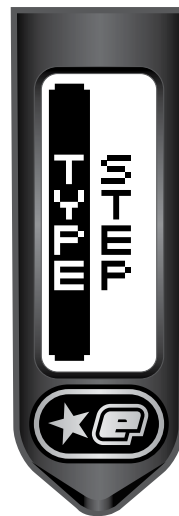

RATE

THE LINEAR RAMP RATE PARAMETER

The parameter is only available when **LINEAR** Ramping is selected and is used to set the percentage increase in rate of fire over rate of trigger pulls.

For example, if the user is pulling the trigger at a rate of 10 pulls per second and the **RATE** parameter is set to 50% then the rate of fire is 10 plus 50% extra which is 15 balls per second.

This parameter can be set between 0 and 100% in 10% increments.



QUICK GUIDE

CONTENTS

ORIENTATION

QUICK SET-UP

USING YOUR GEO

MENU TREE

ADVANCED SET-UP

MAINTENANCE

FAULT FINDING

SERVICE CENTERS

PARTS LIST

SPARES & ACCESSORIES

PULL NO

THE RAMP START PARAMETER

The parameter sets the number of trigger pulls that are required at the **KICK IN** rate before ramping will start. The parameter can be set between 4 and 9 pulls in increments of 1.

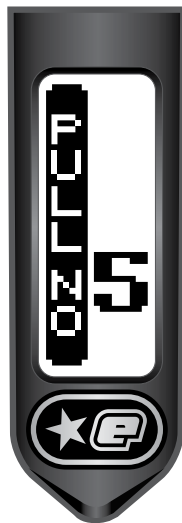

KICK IN

THE RAMP KICK-IN PARAMETER

This parameter sets the minimum rate at which the user has to pull the trigger in order to start ramping. This parameter can be set between 5.0 and 15.0 pulls per second in 0.1 pulls per second increments.

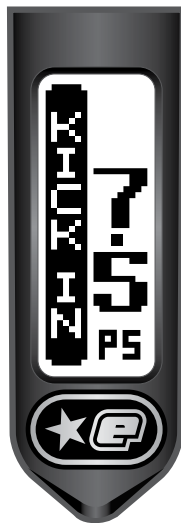

SUSTAIN

THE SUSTAIN RATE PARAMETER

Once the Geo is ramping the user has to continue to pull the trigger at a minimum rate in order to maintain the ramping. This parameter sets this rate and can be between 5.0 and 15.0 pulls per second in 0.1 pulls per second increments.



RESTART

THE RAMP RESTART PARAMETER

The **RESTART** parameter defines the amount of time after the last trigger pull during which the ramp can be restarted with a single trigger pull. If a trigger pull occurs after the **RESTART** time has expired, then the other ramp start conditions have to be met before ramping will restart. This parameter can be set between 0.0 and 1.0 seconds in 0.1 second increments.

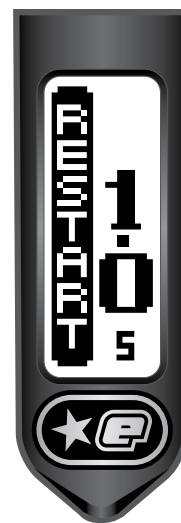

QUICK GUIDE

CONTENTS

ORIENTATION

QUICK SET-UP

USING YOUR GEO

MENU TREE

ADVANCED SET-UP

MAINTENANCE

FAULT FINDING

SERVICE CENTERS

PARTS LIST

SPARES & ACCESSORIES

TIMING

THE TIMING MENU

The parameters on the Timing Menu all relate to the timing of specific events.

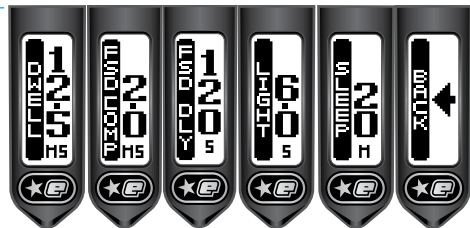

DWELL

THE DWELL PARAMETER

The **DWELL** parameter sets the amount of time that the solenoid is energized and therefore the amount of air that is released with each shot of the Geo. Setting this parameter too low will result in low velocity shots and/or excessive shot to shot velocity fluctuations. Setting the parameter too high will simply waste gas and make the Geo louder.

The **DWELL** can be set between 0.0 and 25.0 milliseconds. The factory default setting can normally be reduced after a few thousand shots as the Geo 'beds-in'.



FSD COMP

THE FIRST SHOT DROP-OFF COMPENSATION PARAMETER

First shot drop off is a reduction in velocity of the first shot fired after an extended period of not firing and is caused by the stiction between dynamic o-rings and the surfaces that they are in contact with. In order to compensate for FSD this parameter can be set to add extra time to the **DWELL** parameter for the first shot. This parameter can be set between 0.0 and 5.0 milliseconds.



FSD DLY

THE FIRST SHOT DROP OFF DELAY PARAMETER

This parameter sets the amount of time after the last shot before the **FSD COMP** is used on the next shot. The first shot after powering on the Geo will always have **FSD COMP**. This parameter can be set between 30 and 240 seconds in 10 second increments.



LIGHT

THE LIGHT PARAMETER

The LCD backlight is illuminated whenever any of the buttons are pressed on the Geo. The **LIGHT** parameter is used to set the amount of time that the backlight stays lit between 0.0 and 20.0 seconds in 0.5 second increments.

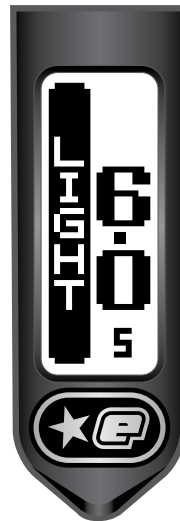

SLEEP

THE SLEEP PARAMETER

If the Geo is inactive for a period of time then it will automatically switch off in order to save power. The **SLEEP** parameter is used to set that time between 5 and 60 minutes in 5 minute increments.



QUICK GUIDE

CONTENTS

ORIENTATION

QUICK SET-UP

USING YOUR GEO

MENU TREE

ADVANCED SET-UP

MAINTENANCE

FAULT FINDING

SERVICE CENTERS

PARTS LIST

SPARES & ACCESSORIES

FILTER

THE FILTER MENU

The parameters on the Filter Menu are all used to tune the Geo's software filters which prevent the Geo from firing unless all of the necessary conditions are met. The factory default settings will be suitable for most set-ups, however certain loader and trigger set-ups may require modification of one or more of these parameters:

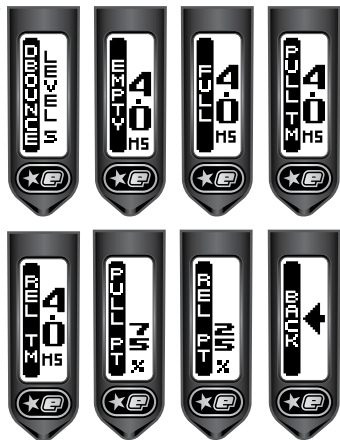

DBOUNCE

THE DEBOUNCE PARAMETER

The **DBOUNCE** parameter is used to combat any trigger bounce that might occur in the Geo and can be set between level 1 and level 9 in one level increments.

- > **LEVEL 9:** Level 9 providing the most filtering.
- > **LEVEL 1:** Level 1 providing the least filtering.
- > **CANCEL:** Cancel editing and leave the parameter unchanged.

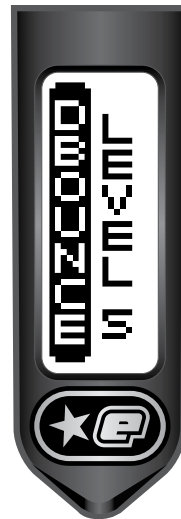

EMPTY

THE EMPTY BREACH TIME PARAMETER

In order for the BBSS to function correctly it must first detect that the bolt is fully retracted and the breach is empty, and then detect that a paintball is loaded into the breach before the Geo is allowed to fire.

Slots or holes in some third party bolts can fool the BBSS and so this parameter is used to specify a minimum time that the breach must be empty. The parameter can be set between 1.0 and 10.0ms in 0.5ms increments.

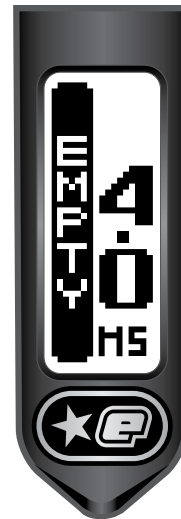

QUICK GUIDE

[CONTENTS](#)
[ORIENTATION](#)
[QUICK SET-UP](#)
[USING YOUR GEO](#)
[MENU TREE](#)
[ADVANCED SET-UP](#)
[MAINTENANCE](#)
[FAULT FINDING](#)
[SERVICE CENTERS](#)
[PARTS LIST](#)
[SPARES & ACCESSORIES](#)

FULL

THE FULL PARAMETER

Tumbling paintballs can take time to settle in the breech before they can be successfully fired. This parameter is used to set the amount of time that a paintball has to be in the breech before the Geo is allowed to fire. This parameter can be set between 1.0 and 20 milliseconds in 0.5ms increments.

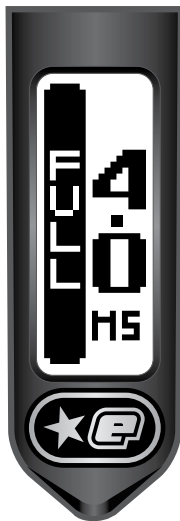

PULL TM

THE PULL TIME PARAMETER

The **PULL TM** parameter is used to set the minimum amount of time that the trigger must be pulled before it is recognised as a valid trigger pull. This parameter can be set between 1.0 and 20.0 milliseconds in 0.5 ms increments.

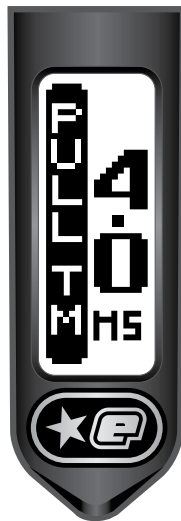

REL TM

THE RELEASE TIME PARAMETER

The **REL TM** parameter is used to set the minimum amount of time that the trigger must be released before it is recognised as a valid trigger release. This parameter can be set between 3.0 and 25.0 milliseconds in 0.1 ms increments.

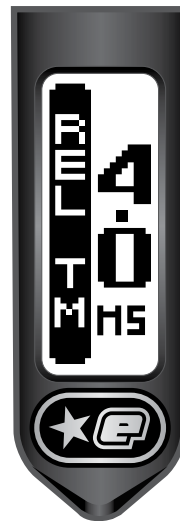

PULL PT

THE PULL POINT PARAMETER

The **PULL PT** parameter is only available if **OPTO** has been selected in the Hardware Menu. **PULL PT** defines the point at which the trigger is considered pulled and is adjustable between 51% and 99% in 1% increments.

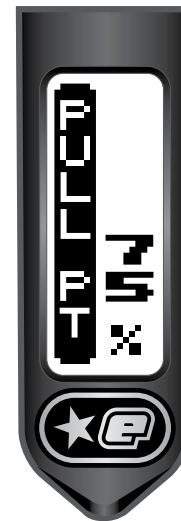

QUICK GUIDE

[CONTENTS](#)
[ORIENTATION](#)
[QUICK SET-UP](#)
[USING YOUR GEO](#)
[MENU TREE](#)
[ADVANCED SET-UP](#)
[MAINTENANCE](#)
[FAULT FINDING](#)
[SERVICE CENTERS](#)
[PARTS LIST](#)
[SPARES & ACCESSORIES](#)

REL PT

THE RELEASE POINT PARAMETER

The **REL PT** parameter is only available if **OPTO** has been selected in the Hardware Menu. **REL PT** defines the point at which the trigger is considered released and is adjustable between 1% and 49% in 1% increments.

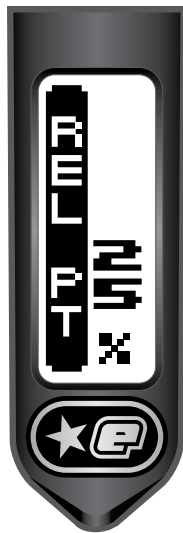

BASIC TRIGGER FILTER SET-UP

The majority of trigger bounce problems can be eliminated by utilizing one of the nine fixed **DBOUNCE** choices (LEVEL 1-9). In attempting to eliminate trigger bounce it is advisable to try the nine fixed **DBOUNCE** choices before attempting any advanced set up of the trigger filters.

ADVANCED TRIGGER FILTER SET-UP

In order to optimize the Trigger Filters it is necessary to have the **PULL PT** parameter set as high as possible and the **REL PT** parameter set as low as possible:

1. Select the **PULL PT** parameter. Observe that the graphical bar rises and falls as the trigger is pulled and released. The actual value of the graphical bar is displayed in the top right of the display.
2. Set the Rear Stop Trigger Screw as required, ensuring that the bar is as close to 100% as possible when the trigger is fully depressed against the set screw. It is advisable to allow for some extra travel in the trigger pull once the bar has reached its maximum value.
3. Adjust the **PULL PT** parameter so that when the trigger is fully depressed the bar settles above the indicator on the left hand side of the screen (see page 49).
4. Select the **REL PT** parameter. Observe that the graphical bar rises and falls as the trigger is pulled and released. The actual value of the graphical bar is displayed in the top right of the display.

5. Set the Front Stop Trigger Screw as required, ensuring that the bar is as close to 0% as possible when the trigger is fully released against the set screw. It is advisable to allow for some extra travel in the trigger release once the bar has reached its minimum value.

6. Adjust the **REL PT** parameter so that when the trigger is fully released the bar settles beneath the indicator on the left hand side of the screen (see page 49).

7. Set the Magnet Return Strength Screw and the Spring Return Strength Screw as required, making both the spring tension and the return force as strong as possible without compromising the "feel" of the trigger.

NOTE: THE FASTEST WAY TO SHOOT A GEO IS TO WALK THE TRIGGER WITH TWO OR MORE FINGERS. FEATHERING (NOT FULLY RELEASING) THE TRIGGER WILL CAUSE THE FILTERING SYSTEM TO REDUCE THE RATE OF FIRE IN ORDER TO ELIMINATE WHAT IT PERCEIVES TO BE TRIGGER BOUNCE.

TRAININ

THE TRAINING PARAMETER

The **TRAININ** parameter is used to select Training Mode. In Training Mode the Geo will function exactly the same as normal but with two important differences:-

1. The solenoid valve is under - driven so that the bolt only moves a small amount and does not release a burst of air. This simulates the firing cycle without wasting air and generating lots of noise.
2. The BBSS is overridden so that the Geo can cycle without paint. The centre of the BBSS indicator changes to a 'T' to indicate that Training Mode is enabled.

The Training parameter choices are as follows:-

- > **OFF:** Training Mode is disabled and the Geo functions normally.
- > **ON:** Training Mode is enabled.
- > **CANCEL:** Cancel editing and leave the parameter unchanged.

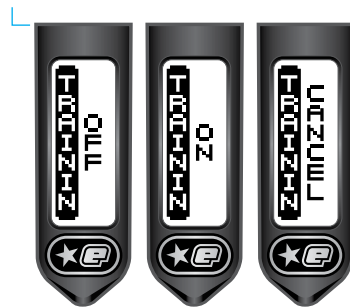

QUICK GUIDE

CONTENTS

ORIENTATION

QUICK SET-UP

USING YOUR GEO

MENU TREE

ADVANCED SET-UP

MAINTENANCE

FAULT FINDING

SERVICE CENTERS

PARTS LIST

SPARES & ACCESSORIES

HARDWARE
THE HARDWARE MENU

The Hardware Menu comprises parameters that control low level functionality of the Geo electronic hardware.

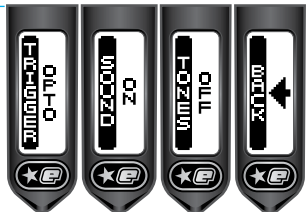

TRIGGER
THE TRIGGER PARAMETER

The Geo is fitted with a dual trigger pull detection system. A non-contact opto-electronic trigger sensor arrangement is used to detect trigger movement whilst a micro-switch is used to provide a more traditional tactile feedback for the trigger. The **TRIGGER** parameter is used to select which system is used. The choices available are as follows:-

- > **OPTO**: Select the Opto sensor for trigger pull detection.
- > **SWITZ**: Select the micro-switch for trigger pull detection.
- > **CANCEL**: Cancel editing and leave the parameter unchanged.



SOUND
THE SOUND PARAMETER

The Geo board is capable of emitting a variety of sounds to audibly indicate when certain functions have been performed, including, but not limited to, powering up, powering off, changing the BBSS mode and successfully changing parameters. This parameter determines if this feature is switched on or off, switching it on will cause more drain on the battery. The choices available for this parameter are:

- > **OFF**: Sounds switched off.
- > **ON**: Sounds switched on.
- > **CANCEL**: Cancel editing and leave the parameter unchanged.

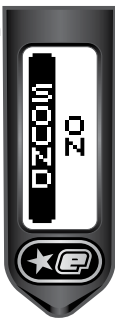

TONES
THE TONES PARAMETER

This parameter sets the Geo emits a tone each time any of the pushbuttons on the Navigation Console are activated. As part of the Smart menu system the **TONES** parameter will only be shown in the Hardware Menu if the **SOUND** parameter is switched on. The choices available for this parameter are:

- > **OFF**: Tones switched off.
- > **ON**: Tones switched on.
- > **CANCEL**: Cancel editing and leave the parameter unchanged.



QUICK GUIDE

- CONTENTS
- ORIENTATION
- QUICK SET-UP
- USING YOUR GEO
- MENU TREE
- ADVANCED SET-UP
- MAINTENANCE**
- FAULT FINDING
- SERVICE CENTERS
- PARTS LIST
- SPARES & ACCESSORIES

CLEANING THE BREAK BEAM SENSOR SYSTEM

⚠ WARNING ///

WARNING: DE-GAS YOUR MARKER, DISCHARGING ANY STORED GAS IN A SAFE DIRECTION, AND REMOVE THE BARREL, LOADER AND AIR SYSTEM TO MAKE THE MARKER EASIER TO WORK ON.

Undo the retaining screw for the Break Beam Sensor Cover on the right hand side of the Geo using a 5/64" (2mm) hex key (SEE FIGURE 9.1).

Remove the Sensor Cover to expose the back of the Break Beam Sensor unit (SEE FIGURE 9.2). Using a dry cotton bud, carefully remove any debris, paint or moisture from the back of the sensor unit and from inside the Sensor Cover.

Lift the BBSS free from the Geo body and using another dry cotton bud, remove any grease or debris build-up from the front of the sensor unit (SEE FIGURE 9.3).



FIG 9.1



FIG 9.2



FIG 9.3

(CONTINUED)

Remove the rubber finger detent and using a dry cotton bud clean the detent and it's location point in the Geo Body. (SEE FIGURE 9.4) Replace the detent back into the Geo body (SEE FIGURE 9.5) and place the BBSS back into the designated slot in the body (SEE FIGURE 9.2). Ensure that the sensor is face down in the body i.e looking into the breach.

Replace the Sensor Cover and using a 5/64" hex key, replace the Break Beam Sensor Cover retaining screw to hold the sensor cover in place (SEE FIGURE 9.6).

NOTE: BE CAREFUL NOT TO CROSS-THREAD THE SCREW. DO NOT OVER TIGHTEN THE SCREW.

Repeat the procedure for opposite side of the Geo.

You have now cleaned your Break Beam Sensor System.

NOTE: WHEN CLEANING BREAK BEAM SENSOR SYSTEM INSPECT CONDITION OF RUBBER FINGER DETENTS AND REPLACE IF NECESSARY. ENSURE THAT THE RECEIVER SENSOR (INDICATED BY A RED MARK & RED HEAT SHRINK) IS LOCATED ON THE RIGHT-HAND SIDE OF THE MARKER BODY.



FIG 9.4



FIG 9.5



FIG 9.6

QUICK GUIDE

CONTENTS

ORIENTATION

QUICK SET-UP

USING YOUR GEO

MENU TREE

ADVANCED SET-UP

MAINTENANCE

FAULT FINDING

SERVICE CENTERS

PARTS LIST

SPARES & ACCESSORIES

CLEANING THE INLINE REGULATOR

⚠ WARNING //////////////////////////////////////

WARNING: DE-GAS YOUR MARKER, DISCHARGING ANY STORED GAS IN A SAFE DIRECTION, AND REMOVE THE BARREL, LOADER AND AIR SYSTEM TO MAKE THE MARKER EASIER TO WORK ON.

NOTE: THE INTERNALS OF YOUR INLINE REGULATOR MAY VARY ACCORDING TO THE MODEL OF GEO THAT YOU HAVE.

Disconnect the macroline hosing from your Inline Regulator allowing it to be unscrewed from the Front Regulator Mount (FRM) (SEE FIGURE 10.1).

Turn the Inline Regulator upside down and carefully unscrew the two sections (SEE FIGURE 10.2). These can be unscrewed by hand or using a 3/8 hex key in the top and a 5/16 hex key in the bottom of the inline regulator.

By firmly gripping the exposed end of the Inline regulator piston, carefully remove the piston and spring in its entirety (SEE FIGURE 10.3).

Insert a 1/8" hex key into the adjuster screw in the bottom half of the Inline Regulator, and wind the screw clockwise through the bottom section of the regulator body (SEE FIGURE 10.4) and pull free when it will no longer turn upwards anymore.

NOTE: THE ADJUSTER SCREW CAN ONLY BE REMOVED BY TURNING IT UPWARDS THROUGH THE BOTTOM SECTION OF THE INLINE REGULATOR. THE REGULATOR WILL BECOME DAMAGED IF THE ADJUSTER SCREW IS REMOVED INCORRECTLY.

Using a dry cotton bud, clean the seal that sits at the top of the body of the bottom section of the Inline Regulator (SEE FIGURE 10.5). Using a light oil and a fresh cotton bud, re-lubricate the seal ready for re-assembly.



FIG 10.1



FIG 10.2



FIG 10.3

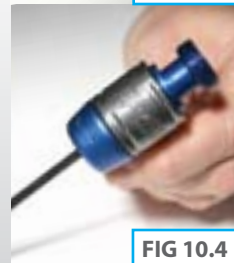

FIG 10.4



FIG 10.5

(CONTINUED)

Thoroughly clean the two o-rings on the adjuster screw and lubricate ready for re-assembly. Inspect the top face of the adjuster unit for any excessive wear or damage as this could cause the Inline Regulator to creep (SEE FIGURE 10.6).

NOTE: THE SEALING FACE ON THE INLINE REGULATOR PISTON CAN ALSO CAUSE THE REGULATOR TO CREEP OR "SUPERCHARGE"; SO THIS SHOULD ALSO BE CHECKED.

With the threaded section towards to the base of the regulator body, re-insert the adjuster screw into the bottom half of the regulator body (SEE FIGURE 10.7). Apply light pressure to the top of the adjuster screw and using a 1/8" hex key wind the adjuster screw counter-clockwise until it stops at the base of the regulator body. Turn the adjuster screw 4 and 1/2 turns in a clockwise direction to set the inline regulator pressure at approximately 120-130 psi.

Take the piston and spring and clean the seal at the top of the piston, re-lubricating it with a light smear of Eclipse Grease ready for re-assembly (SEE FIGURE 10.8). Insert the piston and spring into the top half of the Inline Regulator body (SEE FIGURE 10.9).

⚠ WARNING //////////////////////////////////////

WARNING: THE SPRING IN THE GEO INLINE REGULATOR HAS BEEN DESIGNED SPECIFICALLY FOR THE ECLIPSE GEO. USING ANY OTHER SPRING WILL DAMAGE THE GEO AND VOID YOUR WARRANTY.

Keeping the top half of the Inline Regulator upside down, screw the two halves of the Inline Regulator together (SEE FIGURE 10.10).

You have now stripped, cleaned, lubricated and assembled your Inline Regulator.

NOTE: IF ANY SEALS ARE DAMAGED THEN REPLACE THEM. EXTRA SEALS ARE AVAILABLE IN GEO PARTS KITS AVAILABLE ONLINE AT WWW.PLANETECLIPSE.COM



FIG 10.6



FIG 10.7



FIG 10.8

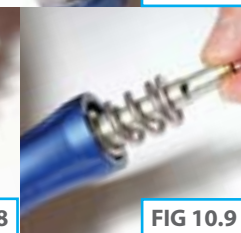

FIG 10.9



FIG 10.10

QUICK GUIDE

CONTENTS

ORIENTATION

QUICK SET-UP

USING YOUR GEO

MENU TREE

ADVANCED SET-UP

MAINTENANCE

FAULT FINDING

SERVICE CENTERS

PARTS LIST

SPARES & ACCESSORIES

MAINTAINING THE BOLT ASSEMBLY

⚠ WARNING ///

WARNING: DE-GAS YOUR MARKER, DISCHARGING ANY STORED GAS IN A SAFE DIRECTION, AND REMOVE THE BARREL, LOADER AND AIR SYSTEM TO MAKE THE MARKER EASIER TO WORK ON.

Using a 1/4" hex key unscrew the Prop Shaft from the marker body (SEE FIGURE 11.1).

Once the threaded section is free from the threads in the marker body and turning freely, pull the Prop Shaft from the marker body (SEE FIGURE 11.2).

Place a finger down the feed neck and push the Bolt free from the Can inside the body by pushing it backwards (SEE FIGURE 11.3). Once the Bolt is free from the Can, insert a finger into the rear of the marker and remove the bolt completely (SEE FIGURE 11.4).



FIG 11.1



FIG 11.2



FIG 11.3

FIG 11.4

(CONTINUED)

By inserting a finger or an appropriately sized hex key into the rear of the marker body (SEE FIGURE 11.5), hook onto one of the holes in the Can and extract it from the marker body (SEE FIGURE 11.6).

You should now have removed the following parts from the marker body: the Can (A), the Bolt (B) and the Prop Shaft (C) (SEE FIGURE 11.7).

Take the Can and having cleaned off any old grease, paint or debris, apply a small amount of Eclipse Grease to the internal o-ring and the 2 external o-rings (SEE FIGURE 11.8).

NOTE: REMOVE ANY EXCESS BLOBS OF ECLIPSE GREASE FROM THE INSIDE AND OUTSIDE OF THE CAN.



FIG 11.5

FIG 11.6



FIG 11.7



FIG 11.8

QUICK GUIDE

CONTENTS

ORIENTATION

QUICK SET-UP

USING YOUR GEO

MENU TREE

ADVANCED SET-UP

MAINTENANCE

FAULT FINDING

SERVICE CENTERS

PARTS LIST

SPARES & ACCESSORIES

(CONTINUED)

Smear a light coat of Eclipse Grease onto the smooth internal bore of the Can from the rear (SEE FIGURE 11.9).

Take the Prop Shaft and having cleaned off any old grease, paint or debris, apply Eclipse Grease to the large rear o-ring and the threads (SEE FIGURE 11.10) and also to the guide o-ring near the front of the Prop Shaft (SEE FIGURE 11.11).

Take the Bolt and having cleaned off any old grease, paint or debris, apply a light film of Eclipse Grease to cover the front end of the bolt and also the internal rear bore of the bolt (SEE FIGURE 11.12). Apply a coat of Eclipse Grease to the 2 external Bolt o-rings near the centre of the bolt (SEE FIGURE 11.13).

Remove excess Eclipse Grease by wiping off with finger. Aim to apply only a very thin film of grease to the components maintained, as excess grease can cause poor performance.



FIG 11.9



FIG 11.10



FIG 11.11



FIG 11.12



FIG 11.13

(CONTINUED)

Slide the Bolt onto the Prop Shaft (SEE FIGURE 11.14) and slide the Can over the Bolt and push into place until the Can touches the star of the Prop Shaft (SEE FIGURE 11.15).

Finally wipe any excess Eclipse Grease off the o-ring on the head of the bolt and insert the complete Bolt Assembly into the marker body (SEE FIGURE 11.16).

Either by hand or using a 1/4" hex key, screw the Bolt Assembly into the marker body (SEE FIGURE 11.17).

If inserted by hand the Prop Shaft and Bolt can be accessed and maintained by hand in future.

NOTE: DO NOT OVER TIGHTEN THE BOLT ASSEMBLY.



FIG 11.14



FIG 11.15



FIG 11.16



FIG 11.17

QUICK GUIDE

CONTENTS

ORIENTATION

QUICK SET-UP

USING YOUR GEO

MENU TREE

ADVANCED SET-UP

MAINTENANCE

FAULT FINDING

SERVICE CENTERS

PARTS LIST

SPARES & ACCESSORIES

HOW TO REMOVE THE FRAME

⚠ WARNING //////////////////////////////////////

WARNING: DE-GAS YOUR MARKER, DISCHARGING ANY STORED GAS IN A SAFE DIRECTION, AND REMOVE THE BARREL, LOADER AND AIR SYSTEM TO MAKE THE MARKER EASIER TO WORK ON.

Disconnect any hosing and unscrew the Inline Regulator from the Front Regulator Mount (FRM) as detailed in the "Cleaning the Inline Regulator" section of this Maintenance Guide.

Using a 5/64" hex key, remove the six screws that attach the Geo Rubber Grips to the Geo Grip Frame (SEE FIGURE 12.1).

Unplug the Solenoid and the Break Beam Sensor System wiring harnesses from their respective ports on the Geo Circuit Board (SEE FIGURE 12.2).

Using a 1/8" hex key, undo and remove the Front Frame Screw (SEE FIGURE 12.3). Using the short arm of a 1/8" hex key, loosen the Rear Frame Screw a full turn (SEE FIGURE 12.4). Slide the Frame backwards approximately half an inch so that the Rear Frame Screw disengages from the Frame and remove the Frame from the Geo Body taking care not to damage any wires (SEE FIGURE 12.5).



(CONTINUED)

You have now removed your Geo Grip Frame from the Geo Body and have access to the Solenoid Assembly and Break Beam Sensor System if maintenance on either is required (SEE FIGURE 12.6).

To install the Frame, carefully thread the Solenoid and the Break Beam Sensor System wiring harnesses through the access hole in the top of the Frame and line the frame up so that the Rear Frame Screw sits in the access hole (SEE FIGURE 12.7).

Be careful not to trap or pinch the BBSS or Solenoid wires behind the rear frame screw or between the body and frame.

Slide the frame forward so that it sits completely flush with the Geo Body and using the short arm of a 1/8" hex key, tighten the Rear Frame Screw into place (SEE FIGURE 12.8).

Insert the Front Frame Screw into its designated position at the front of the Frame and using a 1/8" hex key tighten it into place (SEE FIGURE 12.9).

NOTE: CHECK THAT NO WIRES ARE TRAPPED BEFORE TIGHTENING DOWN THE TWO FRAME SCREWS.

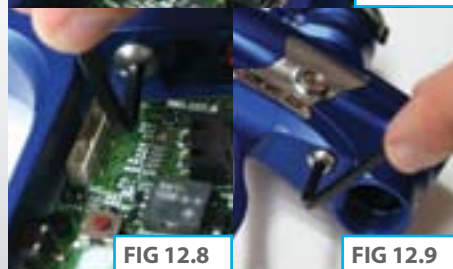

QUICK GUIDE

CONTENTS

ORIENTATION

QUICK SET-UP

USING YOUR GEO

MENU TREE

ADVANCED SET-UP

MAINTENANCE

FAULT FINDING

SERVICE CENTERS

PARTS LIST

SPARES & ACCESSORIES

(CONTINUED)

Connect the Solenoid and Break Beam Sensor System wiring harnesses to their respective ports on the Geo Circuit Board and (SEE FIGURE 12.10).

Adjust the wires so that they sit neatly in the Grip Frame and ensure that the wires do not obstruct either the Micro-switch or the Opto sensor (SEE FIGURE 12.11).

Attach the Geo Rubber Grips to the Frame using a 5/64" hex key to replace the 6 grip screws (SEE FIGURE 12.12).

Screw the Inline Regulator back into the Front Regulator Mount and connect any hosing that was disconnected earlier (SEE FIGURE 12.13).

You have now installed your Geo Grip Frame onto the Geo.



FIG 12.10



FIG 12.11



FIG 12.12



FIG 12.13

THE GEO SOLENOID ASSEMBLY

⚠ WARNING //

WARNING: DE-GAS YOUR MARKER, DISCHARGING ANY STORED GAS IN A SAFE DIRECTION, AND REMOVE THE BARREL, LOADER AND AIR SYSTEM TO MAKE THE MARKER EASIER TO WORK ON.

With the frame separated from the Geo body and the Solenoid Assembly and BBSS Assembly unplugged from the circuit board (see page 62) use a 5/64" hex key to undo and remove the two screws that hold the Solenoid Assembly onto the Geo body (SEE FIGURE 13.1).

With the Solenoid Assembly completely removed from the Geo body the bottom of the Geo body should now resemble FIGURE 13.2 Ensure that the air transfer holes in the bottom of the body are free from contamination from any dirt, debris, paint or moisture and clear away any excess grease if it appears to be blocking any of the transfer holes.

Check the underside of the Solenoid Assembly to ensure that it is also free from damage or debris (SEE FIGURE 13.3) and remove the rubber gasket to clean the filter section as shown in FIGURE 13.4 Replace the rubber gasket ensuring that it lies flat in its designated groove in the minifold body (SEE FIGURE 13.5).

If you are replacing a defective Pilot Assembly, unscrew it from the minifold now and replace it with a new Pilot Assembly unit (SEE FIGURE 13.6).



FIG 13.1



FIG 13.2



FIG 13.3

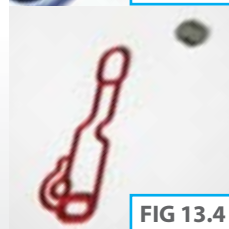

FIG 13.4



FIG 13.5



FIG 13.6

QUICK GUIDE

CONTENTS

ORIENTATION

QUICK SET-UP

USING YOUR GEO

MENU TREE

ADVANCED SET-UP

MAINTENANCE

FAULT FINDING

SERVICE CENTERS

PARTS LIST

SPARES & ACCESSORIES

(CONTINUED)

Using a 5/64" hex key, unscrew and remove the Back-check Assembly from the minifold (SEE FIGURE 13.7). The Back-check Assembly comprises of three parts; the Back-check Ball, the Back-check Spring and the Back-check Cap (SEE FIGURE 13.8). If the Back-check Ball or Spring is deformed or damaged replace as necessary using authentic Geo Spares.

Rebuild the Back-check Assembly by placing the Back-check Ball into hole in the minifold and then attach the Back-check Spring to the end of the Back-check Cap as shown in FIGURE 13.9. Holding the minifold on its end, insert the connected Spring and Cap into their designated hole in the minifold (SEE FIGURE 13.10). Using a 5/64 hex key screw the Back-check Cap back into the minifold to hold the contents of the Back-check Assembly in place (SEE FIGURE 13.11).

NOTE: IF ANY OF THE COMPONENTS OF THE BACK-CHECK ASSEMBLY ARE DAMAGED OR NOT FUNCTIONING CORRECTLY IT WILL CAUSE THE MARKER NOT TO FIRE.

Using an appropriately sized Phillips head screwdriver, remove the Spool Pack Retaining screw from the minifold (SEE FIGURE 13.12) and using a pair of needle nosed pliers remove the Spool Pack from the minifold (SEE FIGURE 13.13).

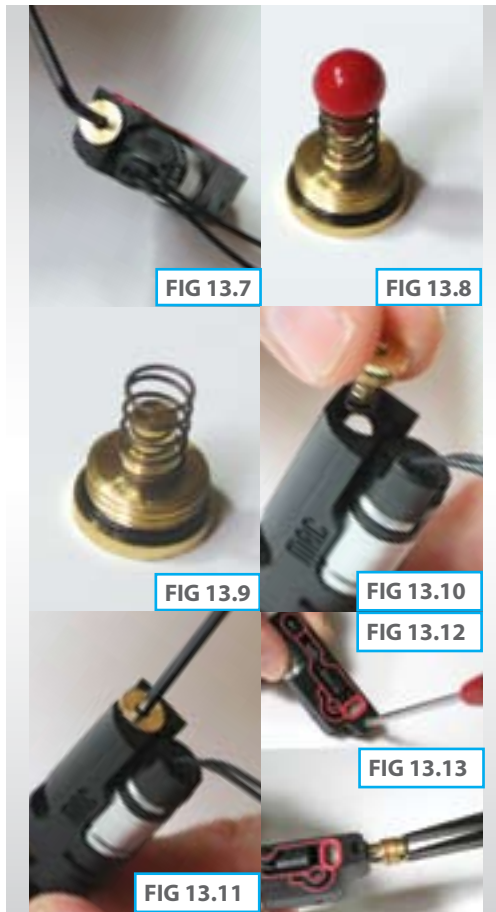

FIG 13.7

FIG 13.8

FIG 13.9

FIG 13.10

FIG 13.12

FIG 13.13

FIG 13.11

(CONTINUED)

Clean off any dirt, debris, paint or grease from the Spool Pack and inspect the o-rings for any signs of wear or damage (SEE FIGURE 13.14). If any of the o-rings on the Spool Pack are damaged replace the entire Spool Pack. Using a dry Q-tip clean the inside of the minifold where the Spool Pack resides ensuring that any dirt, debris and old grease is removed (SEE FIGURE 13.15). Lubricate every o-ring on the outside of the Spool Pack thoroughly with Eclipse Grease and insert the Spool Pack into the minifold making sure that the screw hole in the end (A) lines up with the hole in the minifold (B) (SEE FIGURE 13.16).

Using an appropriate sized Phillips head screwdriver, replace and tighten the Spool Pack Retaining screw into the minifold (SEE FIGURE 13.17).

Hold the Solenoid Assembly onto the bottom of the Geo body, taking care to line it up correctly with the screw holes in the body and to avoid pinching the BBSS wires underneath it (SEE FIGURE 13.18). Use a 5/64" hex key to tighten the two screws that hold the Solenoid Assembly onto the Geo body (SEE FIGURE 13.19).

You have now successfully stripped and cleaned your Geo Solenoid Assembly.

NOTE: DO NOT OVER TIGHTEN THE SCREWS IN THE SOLENOID ASSEMBLY.

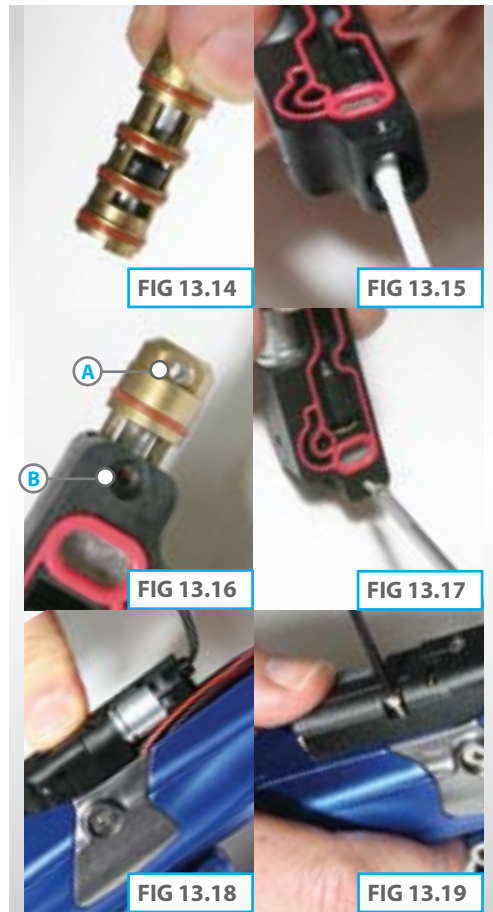

FIG 13.14

FIG 13.15

FIG 13.16

FIG 13.17

FIG 13.18

FIG 13.19

QUICK GUIDE

CONTENTS

ORIENTATION

QUICK SET-UP

USING YOUR GEO

MENU TREE

ADVANCED SET-UP

MAINTENANCE

FAULT FINDING

SERVICE CENTERS

PARTS LIST

SPARES & ACCESSORIES

THE GEO TRIGGER ASSEMBLY

Having removed the trigger frame completely from the Geo body (see page 62), use a 5/64" hex key to remove the two screws that hold the bearing carrier in place in the top of the frame (SEE FIGURE 14.1). Gently lift the bearing carrier and trigger assembly free from the trigger frame taking care not to damage the micro-switch or the opto sensors (SEE FIGURE 14.2).

Using a 1/16" hex key, loosen the trigger pin retaining set screw from the bottom of the trigger (SEE FIGURE 14.3). Use a small hex key to push the trigger pin out of the bearing carrier from one side (SEE FIGURE 14.4).

Clean the trigger and bearing carrier thoroughly and also clean the space within the frame that the trigger sits into.

Carefully remove the Trigger Spring from the spring hole in the top of the Trigger and clean off any paint debris or moisture from it (SEE FIGURE 14.5).



FIG 14.1



FIG 14.2

FIG 14.3



FIG 14.4

(CONTINUED)

Replace the Trigger Spring into the spring hole in the top of the Trigger and position the trigger so that the hole through the trigger lines up with the holes in the bearing carrier, slide the trigger pin in place and using a 1/16" hex key tighten down the trigger pin retaining set screw to hold the assembly together (SEE FIGURE 14.6).

Gently lower the trigger assembly and bearing carrier into the frame, taking care not to damage the micro-switch or the opto sensor, and ensuring that the trigger is positioned correctly (SEE FIGURE 14.7). Using a 5/64" hex key tighten the two screws that hold the bearing carrier in place in the top of the Geo frame.

You have now stripped and cleaned your Geo trigger assembly.



FIG 14.5



FIG 14.6



FIG 14.7

QUICK GUIDE

[CONTENTS](#)
[ORIENTATION](#)
[QUICK SET-UP](#)
[USING YOUR GEO](#)
[MENU TREE](#)
[ADVANCED SET-UP](#)
[MAINTENANCE](#)
[FAULT FINDING](#)
[SERVICE CENTERS](#)
[PARTS LIST](#)
[SPARES & ACCESSORIES](#)

THE GEO ON/OFF PURGE SYSTEM (OOPS)

⚠ WARNING //

WARNING: DE-GAS YOUR MARKER, DISCHARGING ANY STORED GAS IN A SAFE DIRECTION, AND REMOVE THE BARREL, LOADER AND AIR SYSTEM TO MAKE THE MARKER EASIER TO WORK ON.

Having disconnected the macroline hose from the fitting on the OOPS Body, unscrew the OOPS Knob from the OOPS Body (SEE FIGURE 15.1). Clean off any dirt, debris or moisture from the OOPS Knob and the threaded section of the OOPS Body.

Use an appropriately sized hex key to push the OOPS Pin out of the OOPS Body (SEE FIGURE 15.2) and then remove the OOPS Insert using a pair of needle nosed pliers (SEE FIGURE 15.3).

Clean and check the condition of the two o-rings on the outside of the OOPS Insert, replacing as necessary (SEE FIGURE 15.4).



FIG 15.1



FIG 15.2



FIG 15.3

FIG 15.4

(CONTINUED)

Clean and check the condition of the single internal o-ring in the front of the OOPS Insert, replace if necessary (SEE FIGURE 15.5). Lubricate all three of these o-rings liberally using Eclipse Grease (SEE FIGURE 15.6).

Replace the OOPS Insert into the OOPS Body ensuring that the o-ring end goes in first, pushing it into place (SEE FIGURE 15.7).

Lubricate the narrow end of the OOPS Pin with a drop of Eclipse Oil and push the pin, narrow end first, into the OOPS Body so that it sits in the OOPS Insert and pokes through the front of the OOPS Body (SEE FIGURE 15.8).

Screw the OOPS Knob back onto the OOPS body until only a couple of threads are showing (SEE FIGURE 15.9).

Reconnect the macroline hose to the fitting on the OOPS Body (SEE FIGURE 15.10).

You have now successfully cleaned and maintained your On/Off Purge System.



FIG 15.5



FIG 15.6



FIG 15.7



FIG 15.8



FIG 15.9



FIG 15.10

QUICK GUIDE

CONTENTS

ORIENTATION

QUICK SET-UP

USING YOUR GEO

MENU TREE

ADVANCED SET-UP

MAINTENANCE

FAULT FINDING

SERVICE CENTERS

PARTS LIST

SPARES & ACCESSORIES



| SYMPTOM | POSSIBLE CAUSE | SOLUTION |
|---|---|--|
| Although a fresh battery has been fitted, the Geo will not switch on. | The battery has been fitted incorrectly. | Fit the Battery correctly with the positive terminal nearest to the side of the frame. |
| | The battery terminals are not making proper contact with the battery. | Remove the Battery, gently bend the terminals towards where the Battery will sit and then replace the Battery. |
| The battery does not seem to last very long. | The battery type is of a low quality. | Use an alkaline or metal hydride battery. Do not use a low quality or rechargeable battery. |
| The Geo leaks from the Solenoid Assembly. | Check that the Solenoid gasket is intact and seated in its designated pocket in the minifold. | Replace the Solenoid gasket if damaged. |
| | Damaged Geo Solenoid. | Replace Geo Solenoid. |
| | Geo Solenoid Assembly is over-pressurising. | Check the Inline Regulator output pressure and consequent velocity. Adjust accordingly. |
| | Debris on / damage to Spool Pack. | Replace Spool Pack. |
| Geo leaks down the barrel. | Main Prop Shaft 14 x2 NBR 70 o-ring is damaged, dirty or dry. | Replace, clean and lubricate 14 x 2 NBR 70 o-ring on Prop Shaft. |
| | Internal 017 NBR 70 o-ring and external 020 NBR 70 o-rings on Can are damaged, dry or dirty. | Replace, clean and lubricate 017 NBR 70 o-ring and 020 NBR 70 o-rings on Can. |
| Gas vents quickly down the barrel as soon as the Geo is gasses up | Bolt is stuck in a forward position. | Push Bolt backwards. |
| | Main Prop Shaft 014x2 o-ring is damaged or an incorrect size. | Replace with a 014x2 size o-ring. |
| The Geo is chopping or trapping paint. | Loader has too high a force setting or paint is poor quality. | Adjust loader setting and try another brand of paint. |
| | The Break Beam Sensor System is switched off. | Switch on the Break Beam Sensor System. |
| | The Bolt is dirty causing the Sensor System to incorrectly detect a paintball. | Clean the Bolt. |

| SYMPTOM | POSSIBLE CAUSE | SOLUTION |
|--|--|---|
| The Geo is chopping or trapping paint. | The Break Beam Sensor System is dirty causing the incorrect detection of paintballs. | Clean the Break Beam Sensor System. |
| The Geo does not fire. | Trigger and trigger detection method are set up incorrectly. | Set up trigger correctly (refer to "Setting the Trigger" section). |
| | Solenoid Assembly is not plugged into Geo PCB correctly. | Plug Solenoid Assembly plug into its port on the Geo PCB. |
| | The Break Beam Sensor System is enabled but there is no paintball in the breach. | Fill loader with paint. |
| | The Micro-switch is not being activated. | Adjust Micro-switch activation screw accordingly. |
| The Geo does not cycle fully. | Micro-switch is damaged. | Replace circuit board. |
| | Sticky or faulty Back-check Assembly in Solenoid. | Check Back-check Assembly, clean and replace as necessary. |
| | Bolt Assembly dirty or incorrectly lubricated. | Clean, relubricate and replace o-rings on Bolt as necessary. |
| The Geo has low velocity on the first shot. | Dwell set too low. | Increase Dwell. |
| | FSDO parameters are set too low to overcome o-ring stiction. | Adjust FSD COMP and FSD DLY parameters. |
| The Geo has high velocity on the first shot. | FSDO parameters are set too high. | Adjust FSD COMP and FSD DLY parameters. |
| | Inline Regulator pressure creeping. | Strip, clean and maintain Inline Regulator. Replace Inline Regulator Piston if necessary. |
| Geo has velocity drop-off during rapid fire. | Air system/regulator does not flow fast enough to keep up. | Try another air system/regulator and replace as necessary. |
| | Sticky o-rings in Bolt Assembly. | Clean, relubricate and replace o-rings on Bolt Assembly as necessary. |
| | Blocked Filter in Solenoid Assembly. | Clean/replace Filter in Solenoid Assembly as necessary. |
| | Incorrectly assembled Back-check Assembly. | Remove Back-check Assembly, rebuild correctly and replace. |

| SYMPTOM | POSSIBLE CAUSE | SOLUTION |
|---|--|---|
| Geo has velocity drop-off during rapid fire. | Poorly maintained Inline Regulator. | Strip, lubricate and rebuild Inline Regulator. |
| | Battery is poor quality or has insufficient power. | Use an Alkaline or metal hydride battery. Do not use a low quality or rechargeable battery. |
| On/Off Purge System is leaking from front hole. | 006 NBR 90 o-ring inside OOPS Insert is damaged or dry. | Replace the 006 NBR 90 o-ring and lubricate with Eclipse Grease. |
| Geo Trigger is very "bouncy". | Incorrect filter settings. | Check that your trigger filter and debounce settings suit your trigger set-up. |
| The Break Beam Sensor System does not appear to be reading correctly. | The Break Beam Sensor System is dirty. | Clean the Break Beam Sensor System as per the Maintenance Section. |
| | Break Beam Sensors are the wrong way around. | Check that the red receiver is on the right-hand side of the Breach. |
| The Break Beam Sensor System is not reading at all. | There is a broken wire or contact, or a short circuit on either of the Breach Sensor cables. | Check the plug of the cables. Check for cuts or pinches in the sensor cables. |
| | Either sensor is back to front. | Check that the sensors face each other when installed. |
| | Two or more balls are being fed into the breach. | Detents are broken/missing |
| Geo is inconsistent. | Inline Regulator is supercharging. | Strip and clean Inline Regulator. (See Maintenance Section.) |
| Break Beam Sensor System turns itself off after firing. | Eye is dirty. | Clean the eyes. |
| | Eye is faulty. | Replace the eyes. |
| | Eye is out of place. | Re-Install Eyes. Check alignment. |
| When the Geo powers up, the right hand side of the screen is not displayed and the marker will not fire | The trigger is permanently depressed. | Adjust the Trigger until the selected Trigger detection method is activated when the Trigger is released. |

ECLIPSE CERTIFIED SERVICE CENTERS

Are you unsure of where to send your Geo to be repaired or serviced? If your local Eclipse dealer can't assist you, why not contact your nearest Certified Eclipse Service Center and arrange to send it into them to undertake any work that you require.

UNITED KINGDOM & EUROPE

PLANET ECLIPSE LTD

England
Call: +44(0)161 872 5572
Email: technical@planetecclipse.com
Visit: www.planeteclipse.com

OPM

Germany
Call: ++49(0) 211 210 2300
Email: salesforce@paintball.de
Visit: www.paintball.de

ESTRATEGO PORTUGAL

Portugal
Call: ++351 213 863 637
Email: info@estratego.pt
Visit: www.estratego.com

ACTION PAINTBALL GAMES

Russia
Call: +7(0) 95 7851 762
Email: info@paintball.ru
Visit: www.paintball.ru

CAMP

France
Call: +33(0)1 41 09 1004
Email: atelier@paintballcamp.com
Visit: www.paintballcamp.com

SKILL PAINTBALL

Poland
Call: ++48 22 875 2777
Email: info@skill.com.pl
Visit: www.skill.com.pl

ADRENALICIA S.L.

Spain
Call: ++34 669 011 515
Email: jota@adrenalicia.com
Visit: www.adrenalicia.com

PONTO DE MIRA

Portugal
Call: ++351 214 120 144
Email: paintball@pontodemira.com
Visit: www.pontodemira.com

SISSOS

Scandinavia
Call: +358 9 85590093
Email: hasse@paintball.se
Visit: www.sissos.fi

PAINTBALLNORGE AS

Norway
Call: ++47 3802 9710
Email: post@paintballnorge.no
Visit: www.paintballnorge.no

COOLGAMES

Finland
Call: ++358 9 586 5312
Email: mikke@ahaa.fi
Visit: www.coolgames.fi

BREAKOUT KFT

Hungary
Call: ++36 203 563 604
Email: info@joinpaintball.hu
Visit: www.joinpaintball.hu

3.4.1

Switzerland
Call: +46 (0)31 164871
Email: ovski@341.ch / coyut@riot.ch
Visit: www.341.ch

USA & CANADA

PLANET ECLIPSE LLC

Rhode Island
Call: (401) 247 9061
Email: gerry.b@planetecclipse.com
Visit: www.planeteclipse.com

GROUND ZERO PAINTBALL

Southern States
Call: (888) 759 2578
Email: egdesigns@hughes.net
Visit: www.gzpaintball.com

DGX PAINTBALL

West Coast and California
Call: (707) 255 5166
Email: Darin@dgxpaintball.com
Visit: www.dgxpaintball.com

PAINTBALL CENTRAL

Hawaii
Call: (808) 533 0462
Email: ron@pbchawaii.com
Visit: www.pbchawaii.com

PAINTBALL SHOWCASE

East Coast
Call: (401) 353 6040
Email: paintballsupply@aol.com
Visit: www.paintballshowcase.com

PRO STAR PAINTBALL

Midwest
Call: (402) 403 1880
Email: Walt@prostarpb.com
Visit: www.prostarpb.com

BADLANDS PAINTBALL

Canada
Call: (416) 245 3856
Email: techzone@badlandspaintball.com
Visit: www.badlandspaintball.com

MAXIMUM PAINTBALL SPORTS

Texas
Call: (210) 659 0424
Email: dy_xfactor@yahoo.com
Visit: www.texasxfactor.com

EXTREME SKATE AND PAINT

Florida
Call: (305) 248 3145
Email: Mike@espxtremesportz.com
Visit: www.espxtremesportz.com

PAINTBALL CENTRAL

North Carolina
Call: (336) 274 4002
Visit: www.pbballcentral.com

MOUNTAIN VIEW PAINTBALL

California
Call: (909) 373 0998
Email: mvpsteve@mountainviewpaintball.com
Visit: www.mountainviewpaintball.com

DISRUPTIVE PAINTBALL

Arizona
Call: (520) 320 0333
Email: disruptivepaintball@yahoo.com
Visit: www.disruptivepaintball.com

REST OF THE WORLD

ACTION PAINTBALL GAMES

Australia
Call: ++61 2 9679 0011
Email: sales@actionpaintball.com.au
Visit: www.actionpaintball.com.au

EXTREME INDOOR PAINTBALL

Australia
Call: ++61 1 300 972468
Email: daniel@extremeindoorpaintball.com.au
Visit: www.extremeindoorpaintball.com.au

MEGA PLAY MORUMBI PAINTBALL

Brazil
Call: (11) 3771-2969
Email: paintball@megaplaymorumbi.com.br
Visit: www.megaplaymorumbi.com.br

ZONA PAINTBALL

Chile
Email: rrrp@zonapaintball.cl
Visit: www.zonapaintball.cl

FAST DUCKS PAINTBALL

Colombia
Call: 7119410-2382922
Email: Ariel@fastduckspaintball.com
Visit: www.fastduckspaintball.com

SKIRMISH PAINTBALL ASIA

Malaysia
Call: ++603 7722 5629
Email: info@skirmishpaintballasia.com
Visit: www.skirmishpaintballasia.com

THE PAINTBALL SHOP

South Africa
Call: ++27 413640549
Email: info@paintballshop.co.za
Visit: www.paintballshop.co.za

VIPER TC PAINTBALL SUPPLY

Venezuela
Call: 584122060751
Email: vipertcps@hotmail.com

QUICK GUIDE

CONTENTS

ORIENTATION

QUICK SET-UP

USING YOUR GEO

MENU TREE

ADVANCED SET-UP

MAINTENANCE

FAULT FINDING

SERVICE CENTERS

PARTS LIST

SPARES & ACCESSORIES



PART NAME

- | | | |
|--|-------------------------------------|----------------------------------|
| 01 Bolt | 27 Plastic Push Button Strip | 54 Body |
| 02 Bolt Front o-ring | 28 Display Window | 55 Anti Double Ball (ADB) Finger |
| 03 Bolt Bumper o-ring | 29 Navigation Console | 56 Clamping Feed Tube |
| 04 Bolt Rear o-ring | 30 PCB Retaining Screw | 57 Clamping Feed Tube Screw |
| 05 Can | 31 Rear Frame Screw | 58 Printed Circuit Board (PCB) |
| 06 External Can o-rings | 32 Front Frame Screw | |
| 07 Can inner o-ring | 33 Rubber Grip Screw | |
| 08 Prop Shaft | 34 Inline Regulator Top | |
| 09 Rear Prop Shaft o-ring | 35 Inline Regulator Swivel Collar | |
| 10 Middle Prop Shaft o-ring | 36 Inline Regulator Bottom | |
| 11 Prop Shaft Bumper o-ring | 37 Inline Regulator Top o-ring | |
| 12 Prop Shaft Adjuster Assembly | 38 Inline Regulator Piston Assembly | |
| 13 Solenoid Assembly | 39 Inline Regulator Piston o-ring | |
| 14 Pilot Valve | 40 Inline Regulator Spring | |
| 15 Back-check Assembly | 41 Inline Regulator Adjuster Screw | |
| 16 Body Plug | 42 Inline Regulator Adjuster o-ring | |
| 17 9 Volt Battery | 43 Inline Regulator Bottom o-ring | |
| 18 Frame | 44 1/4" Elbow | |
| 19 Trigger | 45 1/4" Hose | |
| 20 Trigger Spring | 46 OOPS Body | |
| 21 Trigger Spring Adjuster Set Screw | 47 OOPS Insert | |
| 22 Trigger Pin Locking Set Screw | 48 External OOPS Insert o-ring | |
| 23 Bearing Carrier Assembly (inc Magnet) | 49 Internal OOPS Insert o-ring | |
| 24 Micro-switch Activation Set Screw | 50 OOPS Pin | |
| 25 Trigger Stop Set Screw | 51 OOPS Knob | |
| 26 Trigger Pin | 52 OOPS Adjuster Screw | |

QUICK GUIDE

CONTENTS

ORIENTATION

QUICK SET-UP

USING YOUR GEO

MENU TREE

ADVANCED SET-UP

MAINTENANCE









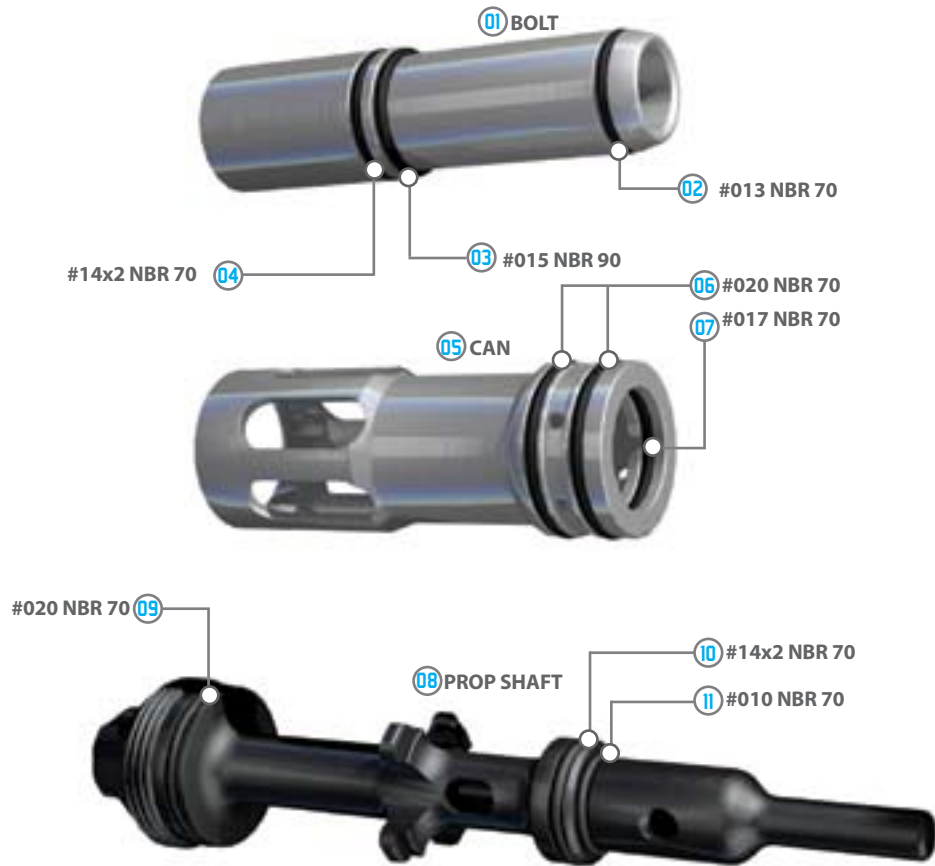

FAULT FINDING









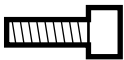
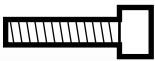

SERVICE CENTERS

PARTS LIST

SPARES & ACCESSORIES



| O-RING | LOCATION | O-RING | LOCATION |
|---|--|---|--|
|  | Can Outer O-Ring Rear Prop Shaft O-Ring |  | Middle Prop Shaft O-Ring Bolt Rear O-ring |
|  | Can Inner O-Ring |  | Bolt Front O-Ring |
|  | Reg Swivel Barrel Back O-Ring |  | Inline Regulator Bottom |
|  | Inline Regulator Piston Inline Regulator Top (NBR 90) Barrel Front O-Ring Bolt Bumper O-Ring (NBR 90) |  | Prop Shaft Bumper O-Ring |
| | |  | Oops Insert External. Prop Shaft Inner O-Ring Prop Shaft Adjuster O-Ring Inline Regulator Adjuster O-Ring |
| | |  | Oops Insert Internal (NBR 90) Body Plug |
| ALL O-RINGS ARE NBR 70 DUROMETER UNLESS OTHERWISE STATED. | | | |

| SCREW | QTY | DESCRIPTION |
|---|-----|--|
|  | 5 | PCB SCREW (3), BEARING CARRIER (2) (M2.5x5 CAP HEAD SOCKET) |
|  | 8 | RUBBER GRIP SCREW (6), BBSS COVERS SCREW (2) (6-32UNC x5/16 COUNTERSUNK SOCKET) |
|  | 1 | SHORT FEED NECK SCREW (1 x10-32UNF x1/2 CAP HEAD SOCKET) |
|  | 1 | LONG FEED NECK SCREW (1 x10-32UNF x5/8 CAP HEAD SOCKET) |
|  | 1 | INLINE REGULATOR ADJUSTER SCREW (CUSTOM MANUFACTURED) |
|  | 1 | MICRO-SWITCH SCREW (6-32 UNC x1/2 SOCKET SET SCREW) |
|  | 5 | TRIGGER ADJUSTMENT SCREW (6-32 UNC x3/16 SOCKET SET SCREW) |
|  | 2 | T-RAIL SCREW (10-32 UNF x1/2 SOCKET SET SCREW) |
|  | 1 | SHORT REAR FRAME SCREW (10-32 UNF x3/8 SOCKET BUTTON HEAD) |
|  | 1 | LONG FRONT FRAME SCREW (10-32 UNF x3/4 SOCKET BUTTON HEAD) |
|  | 1 | BODY PLUG (CUSTOM MANUFACTURED) |
|  | 2 | SOLENOID (2) (M2.5x12 CAP HEAD SOCKET) |

TECH FLEX MAT

Protect your Geo whilst you maintain it with the Eclipse Tech Flex Mat.

GEO COMPREHENSIVE SPARES KIT

Replacement spares to service your Geo (not all spares shown).

ECLIPSE GREASE

The recommended grease to use on all maintenance and servicing procedures that require grease.

ECLIPSE GUN OIL

The recommended oil to use on all maintenance and servicing procedures that require oil.

ECLIPSE EGO9

The perfect kit bag companion to the Eclipse Geo. The Eclipse Ego9 is our most advanced Ego to date.

ECLIPSE TECH SHIRT

The perfect pocket covered garment for carrying all those hex keys and spares for your Geo.

QUICK GUIDE
[CONTENTS](#)
[ORIENTATION](#)
[QUICK SET-UP](#)
[USING YOUR GEO](#)
[MENU TREE](#)
[ADVANCED SET-UP](#)
[MAINTENANCE](#)
[FAULT FINDING](#)
[SERVICE CENTERS](#)
[PARTS LIST](#)
[SPARES & ACCESSORIES](#)

Units 5-8 Southfield Ind Est, Praed Road Trafford Park, Manchester, England, M171SJ
Call UK & Europe: +44 (0)161 872 5572 Call USA & Canada: 401 247 9061

Licensed under one or more of the following patents:
US 6311682, 6615814, 5881707, 5967133, 6035843, 6474326B1, 6637421B2 UK GB 234270, GB 2345953
© Copyright 2008-2009 Planet Eclipse Ltd. Geo and the Geo device are registered trademarks.

GM08VOL2

THE WORLD'S FIRST
EMORTALS
PLANETECLIPSE.COM/EMORTALS

