

ANGEL™

FLY



WARNINGS

Important Safety Instructions & Guidelines	2
--------------------------------------------	---

OPERATING INSTRUCTIONS

Charging	3
Switching On Your ANGEL	3
Making the ANGEL Live / Safe	4
Switching Angel Eyes On/Off	4
Propellant Air/Nitrogen Supply	4
Macro Line Hose/Connector attachment	4
Macro Line Hose removal and re-attachment	5
Loaders (Hoppers)	5
Soft Nose Bolt Removal & Rotor Breech	5
Velocity Adjustment	6
Twist Lock Feed Collar	6
Volumizer Accessories	6

LCD MENUS

Basic Menu	7
<i>Menu – Fetch – Timer – Angel Eyes Test</i>	
Advanced Menu	7 – 8
<i>MROF – Hopper (Loader) T Time – Hopper (Loader) A Time</i>	
<i>Hopper (Loader) Type – Temperature – Vibrator – Trip – Backlight</i>	
<i>SEND IR – ROF – MODE – Dwell – Cycles – ID – Trigger Offset</i>	
Internal Electronic Menus	8
Factory Default Settings	8

FIGURES

1 Basic & Advanced Menus	9
2 Internal Menu	10
3 Internal Text Programming	10
4 Internal PIN Programming	10
5 External PIN Lock/Unlock	11
6 Game Timer Activation	11

MAINTENANCE

General Care and Cleaning	12
General Assembly - Right Hand View	12
General Assembly - Left Hand View	13
Sub Assemblies	13
Cutaway – Right Hand View	14
Cutaway – Left Hand View	14
Mini-Regulator Service	15
Anti-Double Ball Detent Service	15
Angel Eyes Service, Removal, Test & Replacement	16
Micro-Pressure Indicator (Optional)	17
LPR Adjustment	17
LPR Assembly Removal	18
LPR Main Seal Replacement	18
Exhaust Guide Removal	19
Exhaust Valve Stem Removal	19
Ram Stroke Adjustment	20
Ram Removal	20
Ram Servicing	20
OPTO Board	21
Vernier Trigger Adjustments	21
Vernier Trigger Wheel Removal	22
Battery Removal	23
Wiring Connections	23

APPENDIX

Fault Finding Table	24
Useful Conversions	24
Terms of Warranty - EEC/R.O.W Exc USA/CAN	25
WDP Ltd. Express Warranty USA/CAN Only	26
Updates	27
Your Personal Details	27
Notes	28



- This Operators and Users Manual is in English.
- It contains important safety guidelines and Instructions.
- Should you be unsure at any stage, or unable to understand the contents within this manual you must seek expert advice.



- Le mode d'emploi est en Anglais.
- Il contient des instructions et mesures de sécurité importantes.
- En cas de doute, ou s'il vous est impossible de comprendre le contenu du mode d'emploi, demandez conseil à un expert.



- Este manual de (operarios y) usuarios está en Inglés.
- Contiene importantes normas de seguridad e instrucciones.
- Si no está seguro de algún punto o no entiende los contenidos de este manual debe consultar con un experto.



- Diese Bedienungs- und Benutzeranleitung ist in Englisch.
- Sie enthält wichtige Sicherheitsrichtlinien und -bestimmungen.
- Sollten Sie sich in irgendeiner Weise unsicher sein, oder den Inhalt dieses Heftes nicht verstehen, lassen Sie sich bitte von einem Experten beraten.

⚠ WARNING**ADHERE STRICTLY TO THESE AND ALL OTHER SAFETY INSTRUCTIONS AND GUIDELINES****WARNINGS FOR SAFE ANGEL HANDLING**

- The ANGEL is not a toy.
- Careless or improper use, including failure to follow instructions and warnings within this Operator Manual and attached to the ANGEL could cause death or serious injury.
- Do not remove or deface any warnings attached to the ANGEL.
- Paintball industry standard eye/face/ear and head protection designed specifically to stop paintballs and meeting ASTM standard F1776 (USA) or CE standard (Europe) must be worn by user and any person within range.
- Must be at least 18 years of age to purchase the ANGEL.
- Persons under 18 years of age must have adult supervision when using or handling the ANGEL.
- Observe all local and national laws, regulations and guidelines.
- Use only on professional paintball fields where codes of safety are strictly enforced.
- Use compressed air/nitrogen gas only. Do not use CO2.
- Do not exceed 850 psi (58 bar) input pressure.
- Always follow instructions, warnings and guidelines given with any first stage regulator you use with the ANGEL.
- Use 0.68 calibre paintballs only.
- Keep the ANGEL switched off until ready to shoot.
- Treat every marker as if it is loaded.
- Never point the ANGEL at anything you do not intend to shoot.
- Do not shoot at persons at close range.
- Do not shoot at fragile objects such as windows.
- Always measure your markers velocity before playing paintball, using a suitable chronograph.
- Never shoot at velocities in excess of 300 feet (91.44 meters) per second, or at velocities greater than local or national laws allow.
- Do not fire the ANGEL with the breech open or without the bolt in the breech, as high pressure gas will be emitted.
- Do not fire the ANGEL with the pull knob in the unlocked position.
- Never look into the barrel or breech area of the ANGEL whilst the marker is switched on and able to fire.
- Never put your finger or any foreign objects into the paintball feed tube of the ANGEL.
- Never allow pressurised gas to come into contact with any part of your body.
- Always switch off the ANGEL when not in use.
- Always fit a barrel blocking device to your ANGEL when not in use on the field of play.
- Always remove all paintballs from the ANGEL when not in use on the field of play.
- The Twisted Lock Gated Feed™ is designed to retain a number of paintballs in the feed tube and breech area of the ANGEL. Always ensure that these paintballs are removed from the ANGEL when it is not in use on the field of play.
- Always remove the first stage regulator and relieve all residual gas pressure from the ANGEL before disassembly.
- The ANGEL can hold a small residual charge of gas, typically 2 shots, with the first stage regulator removed. Always discharge the marker in a safe direction to relieve this residual gas pressure.
- Always remove first stage regulator and all residual gas pressure from the ANGEL for transport and storage.
- Always follow warnings and guidelines given with your first stage regulator for safe transport and storage.
- Only charge the ANGEL using the charger supplied.
- Only use 12 Volt negative earth vehicles as a power supply for the charger.
- Do not leave the ANGEL unattended whilst charging.
- Always store the ANGEL in a secure place.
- THIS OPERATOR MANUAL MUST ALWAYS ACCOMPANY THE PRODUCT IN THE EVENT OF RESALE OR NEW OWNERSHIP.
- SHOULD YOU BE UNSURE AT ANY STAGE YOU MUST SEEK EXPERT ADVICE.

CHARGING

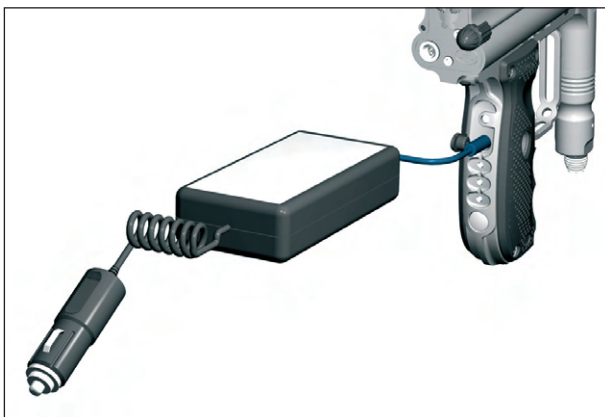

WARNING

ADHERE STRICTLY TO THESE AND ALL OTHER SAFETY INSTRUCTIONS AND GUIDELINES

- Ensure a barrel blocking device is fitted to the ANGEL.
- Ensure the hopper is removed from the ANGEL.
- Ensure that there are no paintballs in the ANGEL.
- Ensure the ANGEL is switched off via the isolating switch at the rear of the marker prior to fitting your first stage regulator.
- Paintball industry standard eye/face/ear and head protection designed specifically to stop paintballs and meeting ASTM standard F1776 (USA) or CE standard (Europe) must be worn by user and any person within range.
- Always follow instructions, warnings and guidelines given with any first stage regulator you use with the ANGEL.
- Use compressed air/nitrogen gas only DO NOT USE CO2.
- Only use a paintball regulator that has been designed for air or nitrogen gas.
- Do not exceed 850 psi (58bar) input pressure to the ANGEL.
- Take suitable precautions when using sharp cutting instruments.
- The Macro Line hose must be cut back cleanly and square prior to attachment or re-attachment to ensure secure fitment.
- SHOULD YOU BE UNSURE AT ANY STAGE YOU MUST SEEK EXPERT ADVICE.

Before initial use of the ANGEL, it is necessary to give the power pack a full charging cycle of 4 hours prior to use as this will ensure a long life for the power pack.

Subsequent charges will be in the region of 3 hours for a full charge, the electronics will control the charging cycle and ensure that your battery is fully charged.

The ANGEL may be left charging for prolonged periods without damage occurring to the battery pack.

- **A full charge will give sufficient power for approximately 150,000 consecutive shots.**
- **A 1-hour charge at 12.5V DC will give sufficient power for approximately 40,000 consecutive shots.**

The ANGEL will continue to use power whilst it is switched **ON**.

To save the charge the isolator switch must be switched **OFF** to isolate the battery.

We recommend the isolating switch be placed in the **OFF** position when the ANGEL is in storage, transit or not in use.

- Insert cigar lighter adaptor into a negative earth socket as found in most motor vehicles (red light on charger will illuminate to indicate that power is present).
- Insert remote plug from charger into the socket on the rear of the ANGEL. The socket is located on the rear of the grip frame under a rubber protection grommet.
- Ensure the isolator switch is in the ON position at the rear panel of the ANGEL. See SWITCHING ON YOUR ANGEL - right.
- The LCD on the ANGEL display will indicate the status of the charging cycle, the bar graph segments on the display will cascade to indicate charge is being taken.
- When a full charge has been taken the bar graph segments will remain illuminated.
- Removal of the charger before a full charge cycle has been completed will result in a short charge.
- **Unplug the charger from the ANGEL and replace the rubber grommet cover on the rear of the grip frame to prevent the entry of dirt or debris.**

IMPORTANT NOTES: For Battery Charging

- *Should the ANGEL be "LIVE" the insertion of the charger will make the ANGEL "SAFE" and unable to fire and removal of the charger will cause the marker to remain in this state until the ANGEL is made "LIVE" again by pressing and holding the red button on the back of the grip frame for 2 seconds.*
- *Supply voltage must be minimum 12V DC, maximum 24V DC, negative earth.*
- *The isolator ON/OFF switch on the back of the ANGEL must be in the ON position to charge the battery.*
- *The battery must be plugged into the circuit board.*
- *Removal of the charger before a full charge cycle has been completed will result in a short charge. Check your vehicle handbook for voltage and current capabilities prior to use.*
- *Use only the charger supplied for charging the ANGEL.*

SWITCHING ON YOUR ANGEL

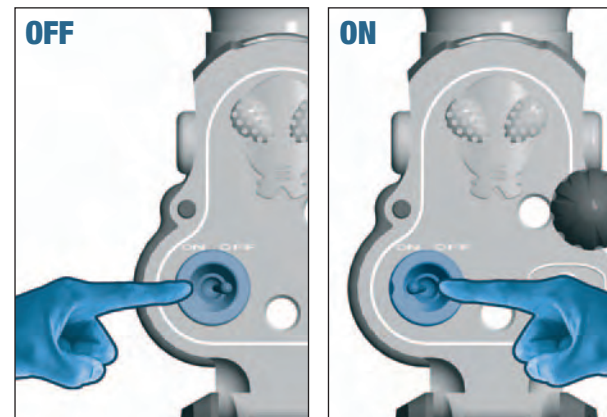

WARNING

ADHERE STRICTLY TO THESE AND ALL OTHER SAFETY INSTRUCTIONS AND GUIDELINES

- Ensure a barrel blocking device is fitted to the ANGEL.
- Ensure the hopper is removed from the ANGEL.
- Ensure that there are no paintballs in the ANGEL.
- Ensure the ANGEL is switched off via the isolating switch at the rear of the marker prior to fitting your first stage regulator.
- Paintball industry standard eye/face/ear and head protection designed specifically to stop paintballs and meeting ASTM standard F1776 (USA) or CE standard (Europe) must be worn by user and any person within range.

- **Ensure the battery is charged.**
- **Switch the isolator switch to the ON position.**
- **The LED on the rear of the grip frame will be Green.**
- **The LCD display will show software version and 'SAFE'.**

MAKING THE ANGEL LIVE



⚠ WARNING

ADHERE STRICTLY TO THESE
AND ALL OTHER SAFETY
INSTRUCTIONS AND GUIDELINES

· THE ANGEL IS LIVE AND CAPABLE OF DISCHARGING.

- Ensure the ANGEL is switched ON. See SWITCHING ON YOUR ANGEL - Page 3.
- Press the top button on the rear of the grip frame for 1 second until the LED on the rear of the frame turns Red and the LCD displays 'LIVE'.

MAKING THE ANGEL SAFE

Press and hold the top button on the rear of the grip frame for 2 seconds until the display indicates 'SAFE', alternatively switch the ANGEL OFF via the isolator switch on the rear of the ANGEL.

LED INDICATOR STATUS ON THE REAR OF THE FRAME

- NO LED = No charge present or isolator switch is OFF.
- GREEN CONSTANTLY ON = SAFE mode.

SWITCHING ANGEL EYES ON/OFF



⚠ WARNING

ADHERE STRICTLY TO THESE
AND ALL OTHER SAFETY
INSTRUCTIONS AND GUIDELINES

· THE ANGEL IS LIVE AND CAPABLE OF DISCHARGING.

- Ensure the ANGEL is switched ON. See SWITCHING ON YOUR ANGEL - Page 3.
- As default the Angel Eyes will always be ON whenever the ANGEL is made LIVE.
- The Angel Eyes can only be switched off by pulling and holding the trigger in for 2 seconds.
- In modes 2 to 5 and Demo, the Angel Eyes cannot be switched off.
- To switch the Angel Eyes back on whilst the ANGEL is LIVE you may either switch the ANGEL OFF and ON via the isolator switch and then make the ANGEL LIVE by pressing the top button, or alternatively make the ANGEL SAFE then LIVE.

LED INDICATOR STATUS ON THE REAR OF THE FRAME

- RED CONSTANTLY ON = LIVE mode, ANGEL EYES OFF.
- RED SLOWLY FLASHING = LIVE mode, ANGEL EYES ON.

PROPELLANT AIR / NITROGEN SUPPLY

⚠ WARNING

ADHERE STRICTLY TO THESE
AND ALL OTHER SAFETY
INSTRUCTIONS AND GUIDELINES

- Ensure a barrel blocking device is fitted to the ANGEL.
- Ensure the hopper is removed from the ANGEL.
- Ensure that there are no paintballs in the ANGEL.
- Ensure the ANGEL is switched off via the isolating switch at the rear of the marker prior to fitting your first stage regulator.
- Paintball industry standard eye/face/ear and head protection designed specifically to stop paintballs and meeting ASTM standard F1776 (USA) or CE standard (Europe) must be worn by user and any person within range.
- Always follow instructions, warnings and guidelines given with any first stage regulator you use with the ANGEL.
- Use compressed air/nitrogen gas only DO NOT USE CO2.
- Only use a paintball regulator that has been designed for air or nitrogen gas.
- Do not exceed 850 psi (58bar) input pressure to the ANGEL.
- Take suitable precautions when using sharp cutting instruments.
- The Macro Line hose must be cut back cleanly and square prior to attachment or re-attachment to ensure secure fitment.
- SHOULD YOU BE UNSURE AT ANY STAGE YOU MUST SEEK EXPERT ADVICE.

The ANGEL is designed to operate on air/nitrogen gas. This needs to be supplied to the ANGEL at an ideal regulated pressure of 400 psi (27.5 BAR) using a suitable first stage paintball regulator, such as the ANGEL A.I.R.

MACRO LINE HOSE

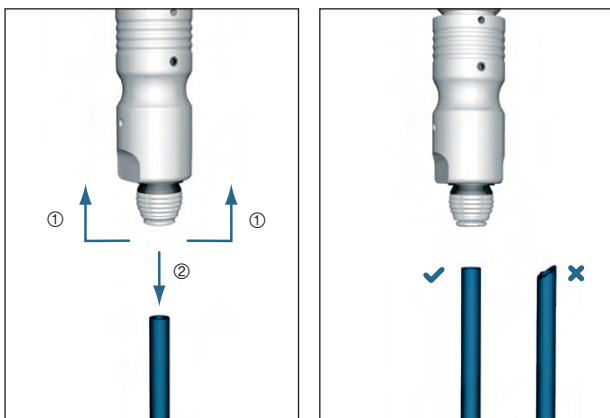

WARNING

ADHERE STRICTLY TO THESE
AND ALL OTHER SAFETY
INSTRUCTIONS AND GUIDELINES

- All gas pressure must be relieved from the ANGEL and second stage regulator prior to the Macro Line hose removal.
- The ANGEL can hold a small residual charge of gas, typically 2 shots with the first stage regulator removed. Always discharge the marker in a safe direction to relieve this residual gas pressure.
- The Macro Line hose must be cut back cleanly and square prior to re-attachment to ensure secure fitment.

MACRO LINE HOSE / CONNECTOR REPLACEMENT

- Connect the Macro Line connector to your first stage regulator outlet port using a suitable wrench or spanner.
- If necessary shorten the Macro Line hose using a sharp knife to the required length to suit your ANGEL and first stage regulator set up.
- Push the free end of the hose firmly into the Macro Line connector attached to the ANGEL second stage regulator.

REMOVAL & RE-ATTACHMENT

- The Macro Line hose may be removed from the Macro Line connectors to facilitate maintenance.
- Pull back the collet ① on the connector and keep the collet depressed.
- Pull the Macro Line hose ② out of the connector firmly.
- Cut back the Macro Line hose cleanly and square.
- Push the hose firmly into the Macro Line connector to re-attach.

LOADERS (HOPPERS)

The ANGEL has been designed to work with all existing loaders and intelligently self adjusts its program to suit the loaders feed rates for the type of loader selected from the Advanced Menu - see page 7, but there are some important things to remember about loaders:

- The Angel Eyes system will shoot paint as fast as your loader is capable of feeding in combination with trigger pulls.
- Some loaders, particularly those with a reflective eye system DO NOT correctly sense twin skin, marbled or dark coloured paintballs, and as such, these loaders are capable of breaking or cracking paintballs before they are even loaded into the ANGEL.
- All loaders should only be used with fresh batteries.
- It is also essential that the loader and its optical system is kept clean at all times.
- Force fed loaders, due to the nature of their design are less tolerant of fragile and poor quality paint, causing breaks in the loader, and feed stack before they are loaded into the ANGEL.
- Some loaders are not capable of sustained feed rates and you will be able to outshoot the loader, causing the Angel Eyes to wait for verification of a paintball before commencing the firing cycle.
- Poorly maintained or damaged loaders will impair the performance capability of the ANGEL.
- To maximise the performance of the ANGEL, WDP recommends only using reliable enhanced feed loaders.

SOFT NOSE BOLT REMOVAL & ROTOR BREECH

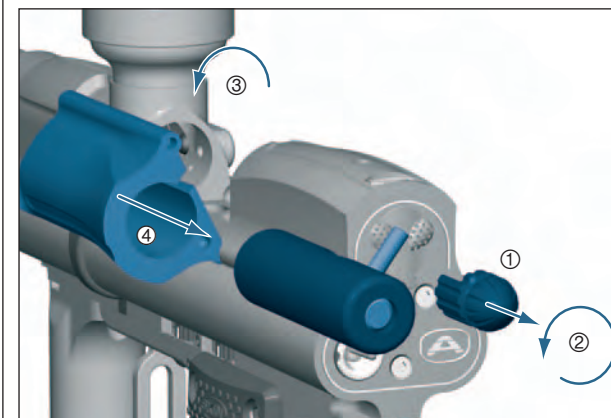

WARNING

ADHERE STRICTLY TO THESE
AND ALL OTHER SAFETY
INSTRUCTIONS AND GUIDELINES

- Do not fire the ANGEL with the breech open or without the bolt in the breech, as high pressure gas will be emitted.
- Do not fire the ANGEL with the pull knob in the unlocked position.

The bolt is manufactured from aluminium and plastic with the wear surfaces being plastic, this is to ensure – due to its high operating speeds – it does not seize within the body. Eventually this will show signs of wear dependent on usage and its environment of use.

It is important that the bolt is kept clean and free of dirt or grit as this will cause accelerated wear. We recommend that you clean your bolt after each day of play.

- Ensure the ANGEL isolator switch is in the OFF position or the ANGEL is in SAFE mode.
- Pull the Pull knob ① and rotate 90 degrees ② so that the knob remains in the unlocked position.
- Swing out the Rotor Breech block ③ so that the bolt is exposed. The breech will not open if the bolt is in the forward position. Ensure it is retracted by either: momentarily gassing the ANGEL or pushing the bolt back with a squeegee.
- Extract the bolt ④ by pulling rearwards.
- To replace the bolt follow the stages in reverse order.

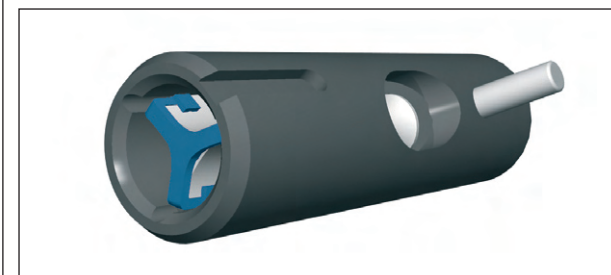

VELOCITY ADJUSTMENT

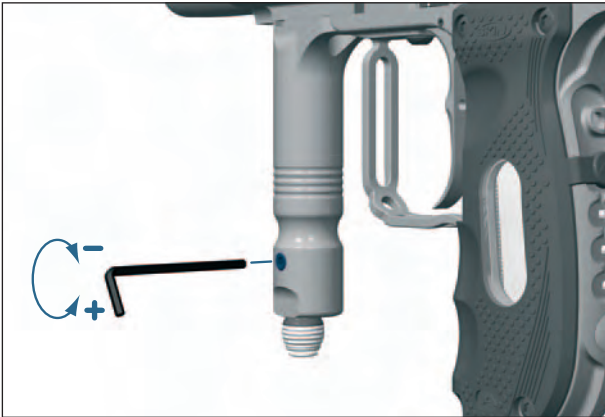

⚠ WARNING

ADHERE STRICTLY TO THESE AND ALL OTHER SAFETY INSTRUCTIONS AND GUIDELINES

- THE ANGEL IS LIVE AND CAPABLE OF DISCHARGING.
- Paintball industry standard eye/face/ear and head protection designed specifically to stop paintballs and meeting ASTM standard F1776 (USA) or CE standard (EU) must be worn by user and any person within range.
- Always measure your markers velocity before playing paintball, using a suitable chronograph.
- Never shoot at velocities in excess of 300ft (91.44 meters) per second, or at velocities greater than local or national laws allow.

DECREASING VELOCITY

The velocity adjusting screw is located on the lower portion of the front grip.

- To decrease the velocity, insert a 3.0mm A/F Allen key and rotate **CLOCKWISE**.
- The new input pressure to the ANGEL may be observed from the micro pressure indicator on the flash tank.

INCREASING VELOCITY

The velocity adjusting screw is located on the lower portion of the front grip.

- To increase the velocity, insert a 3.0mm A/F Allen key and rotate **ANTI-CLOCKWISE**.
- The new input pressure to the ANGEL may be observed from the micro pressure indicator on the flash tank.

IMPORTANT NOTE:

- When reducing velocity, allow four shots for the complete system to be at the new regulated pressure.

TWIST LOCK COLLAR FEED

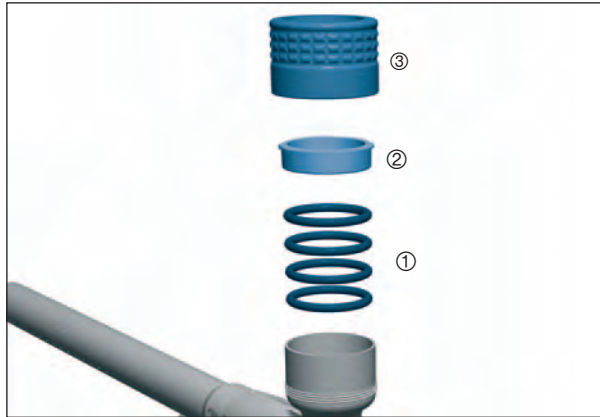

The Twist Lock Feed Collar is a dual feature that retains your loader securely to the ANGEL.

TWIST LOCK COLLAR

- To secure your loader, first ensure the Twist Lock collar is backed off by rotating it counter-clockwise.
- The Twist Lock Collar feature has been supplied with two sizes of 'O' rings ① to ensure that the full range of loader neck sizes are covered. If the loader is difficult to insert when ⑤ has been backed off, follow the procedure to replace the 'O' rings:
- Unscrew ⑤ by rotating counter clockwise.
- Extract spacer ②.
- Extract 'O' rings ① and replace with compatible size.
- Re-assemble in reverse order.
- Insert the loader into the feed neck and rotate the Twist Lock collar clockwise to secure the loader.

VOLUMIZER ACCESSORIES

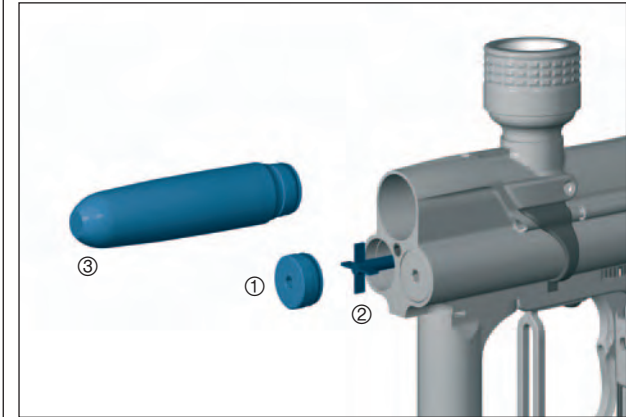

⚠ WARNING

ADHERE STRICTLY TO THESE AND ALL OTHER SAFETY INSTRUCTIONS AND GUIDELINES

- Ensure a barrel blocking device is fitted to the ANGEL.
- Ensure the hopper is removed from the ANGEL.
- Ensure that there are no paintballs in the ANGEL.
- Always remove the first stage regulator and relieve all residual gas pressure from the ANGEL before disassembly.
- The ANGEL can hold a small residual charge of gas, typically 2 shots, with the first stage regulator removed. Always discharge the marker in a safe direction to relieve this residual gas pressure.

The ANGEL has been designed to accept volumizers that attach to the front of the ANGEL. Attachment of volumizers will allow the working pressure of the ANGEL to be reduced to suit specific performance requirements.

The volumizer supplied with your ANGEL will reduce the operating pressure to approximately 150 psi.

- Unscrew and remove the mini regulator.
- Remove the left end cap ① using suitable metric 4.0mm A/F Allen key.
- Ensure the valve spring, support bobbin ② and exhaust valve stem remain in place.
- Replace the left hand cap with the volumizer - ③

IMPORTANT NOTES: For re-assembly of components

- Ensure the valve spring, support bobbin and exhaust valve stem remain in place.
- Ensure the end cap is located correctly.

DUAL EXTERNAL LCD MENUS IN SAFE MODE – BASIC MENU

⚠ WARNING

ADHERE STRICTLY TO THESE AND ALL OTHER SAFETY INSTRUCTIONS AND GUIDELINES

- Ensure a barrel blocking device is fitted to the ANGEL.
- Ensure the hopper is removed from the ANGEL.
- Ensure that there are no paintballs in the ANGEL.

FEATURE	MENU ALLOCATION	EXTERNAL VIEW	EXTERNAL ADJUST	PARAMETER
MENU	BASIC	YES	YES	Basic/Adv
FETCH	BASIC	YES	YES	ON/OFF
TIMER	BASIC	YES	YES	0.5-30min
A1	BASIC	YES	YES	0.5-30min
A2	BASIC	YES	YES	0.5-30min
A3	BASIC	YES	YES	0.5-30min
ANGEL EYE TEST	BASIC	NO	YES	Pass/Fail

VIEWABLE EXTERNAL MENU

The ANGEL has a number of features that may only be adjusted or viewed on the LCD screen. The menu that is displayed can be split into two main categories - Basic and Advanced. There is a division between basic and advanced menus. As default, the menu divisions are factory set.

- This is a basic viewing menu that is designed for speed of use and allows you to quickly view basic menu items; these are settings for the items you are most likely to use whilst at a tournament.
- Any menu items that may change the performance of the ANGEL CANNOT be adjusted externally e.g. Dwell, Trigger Offset and Mode.

FACTORY DEFAULT BASIC MENU SETTINGS MENU

Allows you to select either Basic or Advanced menu options.

FETCH

Allows you to put your ANGEL in receiver mode so that it will receive data/settings transmitted from other ANGEL markers or PDA's.

TIMER, A1, A2, A3 FEATURE

This is a fully interactive game timer with 3 independent alarms and will allow you and your team members to play in unison. The timer may be set in 30 second increments from 0 to 30 minutes. The 3 independent alarms may also be set in 30 second increments giving you a very versatile game timer and alarm system. Once the alarms are set they will be activated by the first trigger pull after making the ANGEL LIVE.

ANGEL EYE TEST FEATURE – Whilst the ANGEL is in SAFE Mode.

- From the Basic or Advanced menu select Angel Eyes Test option using the middle button externally or the blue button internally.
- Press the bottom button externally and the display will show 'dropB'.
- Drop a paintball into the breach.
- When the paintball is detected the display will show 'PASS'.
- Failure to obtain the 'PASS' message is an indication that the Angel Eyes need cleaning or servicing.

DUAL EXTERNAL LCD MENUS IN SAFE MODE – ADVANCED MENU

⚠ WARNING

ADHERE STRICTLY TO THESE AND ALL OTHER SAFETY INSTRUCTIONS AND GUIDELINES

- Ensure a barrel blocking device is fitted to the ANGEL.
- Ensure the hopper is removed from the ANGEL.
- Ensure that there are no paintballs in the ANGEL.

FEATURE	MENU ALLOCATION	EXTERNAL VIEW	EXTERNAL ADJUST	PARAMETER
MENU	ADV & BASIC	YES	YES	Basic/Adv
FETCH	ADV & BASIC	YES	YES	ON/OFF
TIMER	ADV & BASIC	YES	YES	0.5-30min
A1	ADV & BASIC	YES	YES	0.5-30min
A2	ADV & BASIC	YES	YES	0.5-30min
A3	ADV & BASIC	YES	YES	0.5-30min
ANGEL EYE TEST	ADV & BASIC	NO	YES	Pass/Fail
MROF	ADVANCED	YES	YES	8-25bps
Hopper T Time	ADVANCED	YES	YES	0.01-1.0 Secs
Hopper A Time	ADVANCED	YES	YES	1-4 Shots
Hopper Type	ADVANCED	YES	YES	STD/MED/FAST/SFAST
TEMP	ADVANCED	YES	YES	°C / °F
VIBRATOR	ADVANCED	YES	YES	ON/OFF
TRIP	ADVANCED	YES	YES	Re-Zero
BACKLIGHT	ADVANCED	YES	YES	ON/OFF
SEND	ADVANCED	YES	YES	ON/OFF
ROF	ADVANCED	YES	YES	Re-Zero
MODE	ADVANCED	YES	NO	Where Applicable
DWELL	ADVANCED	YES	NO	9-20m/s
TRIGGER OFFSET	ADVANCED	YES	NO	1-20 Levels
CYCLES	ADVANCED	YES	NO	Non-Resetable
ID	ADVANCED	YES	NO	Non-Resetable

VIEWABLE EXTERNAL MENU

- This is an advanced viewing menu that allows you to view the full menu for the items you are most likely to use whilst setting up your ANGEL.
- Any menu items that may change the performance of the ANGEL CANNOT be adjusted externally e.g. Dwell, Trigger Offset and Mode.

FACTORY DEFAULT ADVANCED MENU SETTINGS

In addition to the seven items in the Basic menu, the Advanced menu contains the following:

MROF

This allows you to tune your maximum rate of fire whilst the Angel Eyes modes are OFF. The MROF should not be set greater than your loader is capable of delivering. Whilst the user is in Angel Eyes mode, all limitations to the MROF are removed enabling you to fire at the fastest possible rates.

HOPPER (LOADER) T TIME FEATURE

This allows the user to set the hopper (loader) activation time and is settable from 0.1 to 2.0 seconds. This is the time period that the intellifeed will supply a signal output for the hopper (loader).

HOPPER (LOADER) A ACTIVATION FEATURE

This allows the user to set the hopper (loader) activation point and can be set to activate on the following;

- A1 = Activates on every shot
- A2 = Activates of a ROF of 2 shots or greater
- A3 = Activates of a ROF of 3 shots or greater
- A4 = Activates of a ROF of 4 shots or greater

HOPPER (LOADER) TYPE

This allows you to select the correct Angel Eye settings for the type of loader that you are using. Once you have selected the correct setting the Angel Eyes program will intelligently adjust itself to the variable speeds of your loader.

STD = 9v Agitator type loaders

MED = 12-18v Agitator type loaders

FAST = Force-fed type loaders

SFAST = Fast force-fed type loaders

TEMP FEATURE

This allows you to select Fahrenheit or Centigrade and monitors the environmental temperature that the marker is exposed to.

VIBRATOR FEATURE

Should the game timer vibrator alarm function not be required this feature allows you to disable the vibrator. The game timer will still function with the vibrator disabled but no interactive alarms will activate.

TRIP FEATURE

This is a resettable shot counter that allows you to view the total number of shots you have fired, and can be referred to at any stage, eg. per game, per day or per event.

BACKLIGHT FEATURE

This allows you to switch the display backlight on/off.

SEND IR FEATURE

This allows you to switch on the infra red transmitter and be capable of transmitting infra red data to other ANGELS. SEND IR will transmit the Game Timer and its alarms information and will also switch on the vibrator and reset the trip meter.

ROF FEATURE

This will record your highest rate of fire achieved shooting your ANGEL. The data is constantly updated with the highest reading achieved should it exceed the previous readings to ensure that you record the latest data. You can reset this when necessary.

MODE FEATURE

WARNING

ADHERE STRICTLY TO THESE
AND ALL OTHER SAFETY
INSTRUCTIONS AND GUIDELINES

· In certain countries local applicable laws or industry standards may mean certain modes may not be enabled or allowed. Check with law enforcement office, or local professional paintball venue.

• **MODE 1: SEMI MODE WITH ANGEL EYES**

The ANGEL Semi Mode with Angel Eyes works on the following principles:

- The Angel Eyes will default to ON whenever the ANGEL is made LIVE via the top button located at the rear of the frame.
- The ANGEL will only fire when a paintball is present.
- The Angel Eyes system is a break beam system that is not affected by colour, shape or finish of paintballs.
- The ANGELs MROF with Angel Eyes is non-capped at 31 BPS.
- To switch the Angel Eyes OFF the trigger must be held down for 2 seconds.

• **MODE 1: SEMI MODE**

The ANGEL Semi Mode works on the following principles:

- In this mode the Angel Eyes are de-activated.
- The ANGEL will fire whether a ball is present or not.
- To activate the Angel Eyes after it has been switched off the ANGEL may either be switched OFF, then ON again or made SAFE then LIVE.
- The MROF with the Angel Eyes OFF will be at whatever MROF you have previously set it to.

• **MODE 2: AUTO MODE**

The ANGEL Auto Mode works on the following principles:

- The Angel Eyes will default to ON whenever the ANGEL is switched ON via the SAFE LIVE top button located on the rear of the frame.
- This is full auto and will fire for as long as the trigger is held or until a paintball is not present.
- This mode is limited to a MROF of 15 balls per second.
- This mode will only work with Angel Eyes on and it cannot be deactivated.

• **MODE 3: 3 SHOT BURST MODE**

The ANGEL 3 Shot Burst Mode works on the following principles:

- The Angel Eyes will default to ON.
- This is a 3 shot burst and will fire for as long as the trigger is held for up to 3 shots or until a paintball is not present.
- This mode is limited to a MROF of 15 balls per second.
- This mode will only work with Angel Eyes on and it cannot be deactivated.

• **MODE 4: RAMP MODE**

The ANGEL Ramp Mode works on the following principles:

- The Angel Eyes will default to ON.
- This is an 8 shot burst and will fire for as long as the trigger is held for up to 8 shots or until a paintball is not present.

- The BPS that these 8 balls will be fired, increases over the string of 8 shots.
- This mode is limited to a MROF of 15 balls per second.
- This mode will only work with Angel Eyes on and it cannot be deactivated.

• **MODE 5: ACCUM MODE**

The ANGEL Accumulator Mode works on the following principles:

- The Angel Eyes will default to ON.
- This is a BPS enhancer that will fire more balls than trigger pulls.
- This mode is limited to a MROF of 15 balls per second.
- This mode will only work with Angel Eyes on and it cannot be deactivated.

• **DEMO MODE**

This is a dry firing mode for firing the ANGEL when on display and is designed to demonstrate the rate of fire achievable. It should only be used for demonstration purposes, as the Angel Eyes feature is reverse functioned so that it cannot fire paintballs. Should a paintball be detected it will prevent the ANGEL from firing.

DWELL FEATURE

This controls the valve opening time. Longer Dwell will use more gas and will generate more noise but allows the ANGEL to be more tolerant to paintball variations. Shorter Dwell will generate less noise and use less gas but will not tolerate poor paint quality.

CYCLES FEATURE

This is the ANGEL equivalent of a milometer and will register the total shot count that the ANGEL has fired.

ID FEATURE

This is a unique serial number identification that is factory set.

TRIGGER OFFSET FEATURE

WARNING

ADHERE STRICTLY TO THESE
AND ALL OTHER SAFETY
INSTRUCTIONS AND GUIDELINES

· Never adjust your trigger offset so finely that accidental discharge may occur due to shock loads or vibrations.

This allows the user to set the trigger snubber and can be used to ensure that trigger bounce is reduced on triggers that have been set. It should be used to eliminate trigger bounce and not used to induce trigger bounce. The level of snubbing required will be dependent on the users setting of the mechanical adjustments of the trigger. The snubber will be automatically set to the highest level of protection on all non semi modes. It is the user's responsibility to ensure that the setting they have selected does not cause accidental discharges.

Level 1 is the maximum trigger damping and increasing the level, reduces the damping.

INTERNAL ELECTRONIC LCD MENUS

WARNING

ADHERE STRICTLY TO THESE
AND ALL OTHER SAFETY
INSTRUCTIONS AND GUIDELINES

- Ensure a barrel blocking device is fitted to the ANGEL.
- Ensure the hopper is removed from the ANGEL.
- Ensure that there are no paintballs in the ANGEL.

The ANGEL has a number of features that can be adjusted to suit your individual needs. These features can change the performance of your marker and are only adjustable via the internal menu. This is to ensure that they pass tournament and field operator requirements.

The settings you have selected may be viewed externally but cannot be adjusted externally.



The menus can only be accessed when the marker is switched ON and in SAFE.













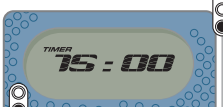

Remove left hand grip cover screws to expose the circuit board.

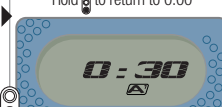

Follow the internal menu list diagrams for relevant settings.

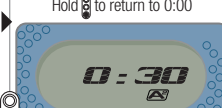



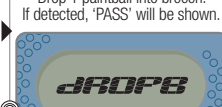



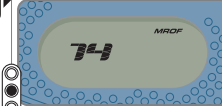
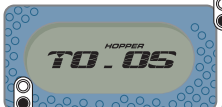

The ANGEL has the unique feature that allows you to return to the factory defaults settings by pressing and holding the internal menu button for 2 seconds.

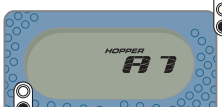
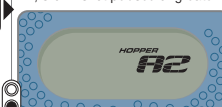
KEY

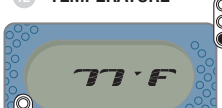





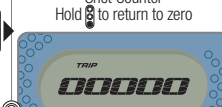



-  Press Top Button
-  Press Middle Button
-  Press Bottom Button

BASIC/ADV MENU	SUB MENU
1 MENU 	Basic / Advanced Advanced includes Basic Items. 
2 FETCH 	ON / OFF – If no signal detected, will default to OFF in 30 Secs. 
3 TIMER 	Game Timer – 0.5 to 30 mins. Hold  to return to 0:00 
4 ALARM 1 	Icon will flash – 0.5 to 30 mins. Hold  to return to 0:00 
5 ALARM 2 	Icon will flash – 0.5 to 30 mins. Hold  to return to 0:00 
6 ALARM 3 	Icon will flash – 0.5 to 30 mins. Hold  to return to 0:00 
7 ANGEL EYE TEST 	Drop 1 paintball into breach. If detected, "PASS" will be shown. 

BASIC TO  1 ADV TO  8

ADVANCED MENU	SUB MENU
8 MROF 	Maximum Rate Of Fire 8 to 25 bps 
9 HOPPER 'T' TIME 	Hopper Motor Running Time 0.05 to 1.0 Seconds 
10 HOPPER 'A' TIME 	Activates after each shot or after 2, 3 or 4 shot per/sec or greater. 
11 HOPPER TYPE 	Hopper (Loader) type: STD, MED FAST, SFAST 
12 TEMPERATURE 	Centgrade or Fahrenheit 
13 VIBRATOR 	Vibes Game Alert On or Off 
14 TRIP 	Shot Counter Hold  to return to zero 

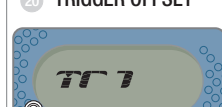
TO  14 BACKLIGHT

ADVANCED MENU	SUB MENU
15 BACKLIGHT 	On or Off 
16 SEND 	IR Send - On/Off - If no signal, defaults to Off after 30 sec inactivity. 
17 ROF 	Achieved Rate of Fire Hold  to return to zero 
18 MODE 	Firing Mode No External Access - see fig. 2
19 DWELL 	Valve Dwell No External Access - see fig. 2
20 TRIGGER OFFSET 	Trigger Offset No External Access - see fig. 2
21 CYCLES 	Total Shots Non Resetable

TO  1 MENU

KEY

- Press Top Button
- Press Middle Button
- Press Bottom Button
- Press BLUE Internal
- Press YELLOW Internal

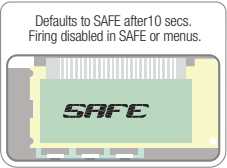

INTERNAL MENU	SUB MENU
<p>1 DWELL</p>	<p>Valve Dwell 10 - 24 milliseconds</p>
<p>2 TRIGGER OFFSET</p>	<p>Range 1 - 20, the lower the number, the lower the offset.</p>
<p>3 MODE</p>	<p>Firing Mode - only enabled if the specification permits.</p>
<p>4 RESET</p>	<p>Resets to default factory settings.</p>

TO 1 DWELL

TEXT PROGRAMMING	NOTES
<p>1 TRIGGER</p>	Text Programming can only be completed with the trigger held in and the ANGEL in 'SAFE' Mode.
<p>2 TEXT</p>	Press Internal to enter TEXT Mode.
<p>3 INITIATE</p>	Press again to initiate TEXT entry.
<p>4 SCROLL</p>	Press to scroll through digits 0 to 9 and A to Z.
<p>5 CONFIRM DIGIT</p>	Press to confirm digit. Repeat Steps 4 and 5 until TEXT complete.
<p>6 CONFIRM TEXT</p>	Press to confirm TEXT. Or press to clear and return to Step 4.
<p>7 TEXT SET</p>	Upon confirmation, the LCD will display 'SET'

PIN PROGRAMMING	NOTES
<p>1 TRIGGER</p>	Programming the PIN number can only be completed with the trigger held in and the ANGEL in 'SAFE' Mode.
<p>2 PIN</p>	Press Internal to enter PIN Mode.
<p>3 INITIATE</p>	Press again to initiate PIN number entry.
<p>4 SCROLL</p>	Press to scroll through digits 0 to 9.
<p>5 CONFIRM DIGIT</p>	Press to confirm digit. Repeat Steps 4 and 5 until PIN complete.
<p>6 CONFIRM PIN</p>	Press to confirm PIN. If PIN correct, ANGEL will enter 'SAFE' Unlocked Mode. Or press to clear and return to Step 4.
<p>7 PIN SET</p>	Upon confirmation, the LCD will display 'SET'

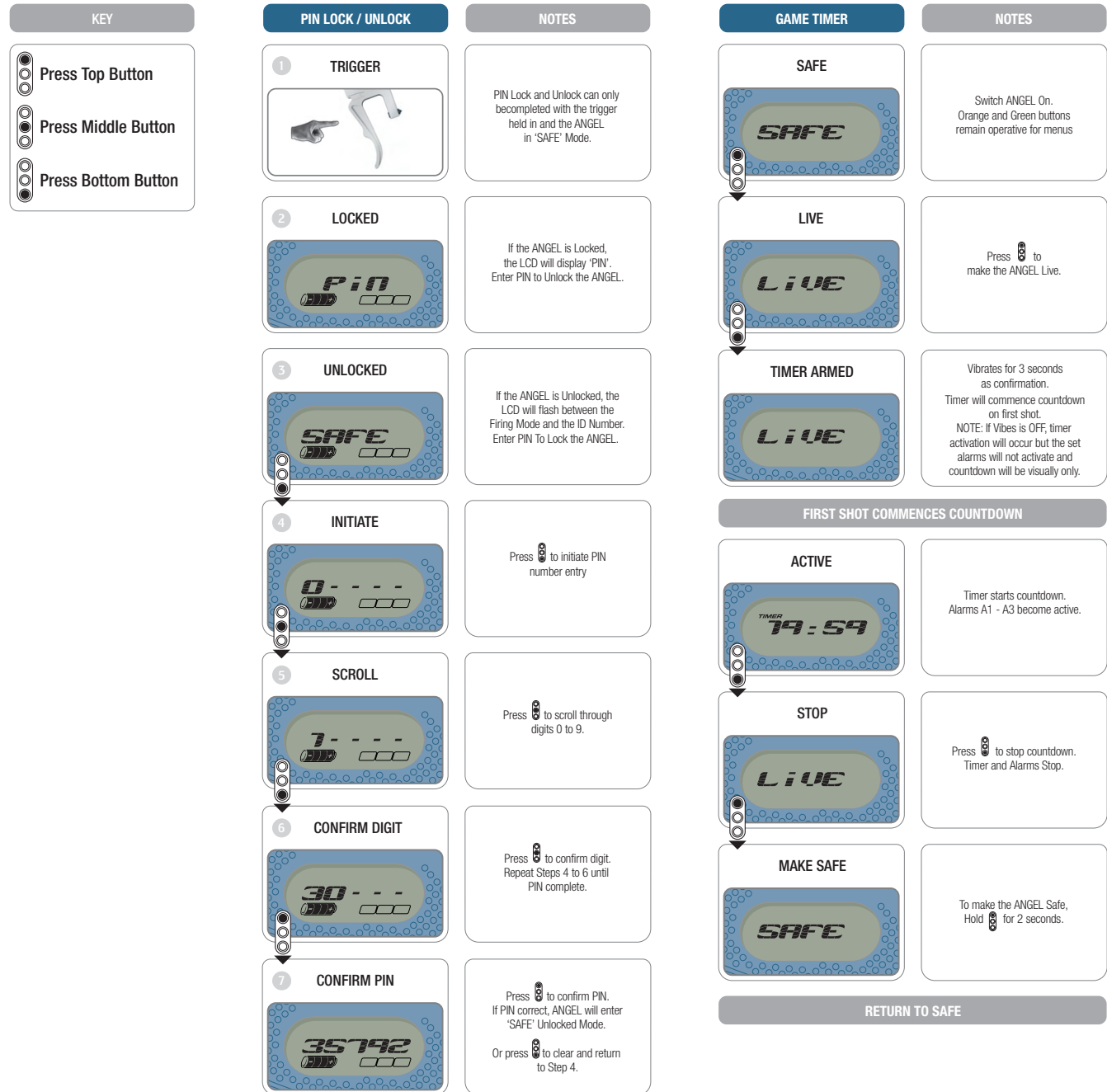

GENERAL CARE & CLEANING

⚠ WARNING

ADHERE STRICTLY TO THESE
AND ALL OTHER SAFETY
INSTRUCTIONS AND GUIDELINES

- Ensure a barrel blocking device is fitted to the ANGEL.
- Ensure the hopper is removed from the ANGEL.
- Ensure that there are no paintballs in the ANGEL.
- Always remove the first stage regulator and relieve all residual gas pressure from the ANGEL before disassembly.
- The ANGEL can hold a small residual charge of gas, typically 2 shots, with the first stage regulator removed. Always discharge the marker in a safe direction to relieve this residual gas pressure.

The ANGEL should only be cleaned externally using a synthetic oil moistened cloth only. Under no circumstances should you use hydrocarbon based oils, as these will cause irrevocable damage to the internal seals, e.g.: WD40, Vaseline, Duck Oil, Engine oil, Plus Gas, 3in1. The suitable oil is Love Juice Oil.

The ram shaft and internal parts that are accessible during disassembly and re-assembly should be lubricated with Love Juice Extreme Grease.

The frequency of lubrication should be every event or at least 8000 shots for oil lubrication and 20,000 shots for grease lubrication. The ANGEL should never be immersed into water otherwise damage may occur to the electronics.

The electronics are moisture/damp proof to IP65. Ensure correct tools are used.

IMPORTANT NOTES: For General Maintenance

- No solvents or abrasive cleaning products should be used. All external and internal accessible moving parts should be lubricated using light synthetic oil only.
- All threads are metric except gun accessory mountings onto the grip frame, which is industry standard 10/32 UNF at centres 0.75 inches. The screw thread length must not exceed 0.375 inches (10mm) into the bottom of the frame otherwise damage will occur to the electronics. We recommend that you remove the left-hand cheek cover and ensure the screws do not project into the circuit board cavity when fitting.

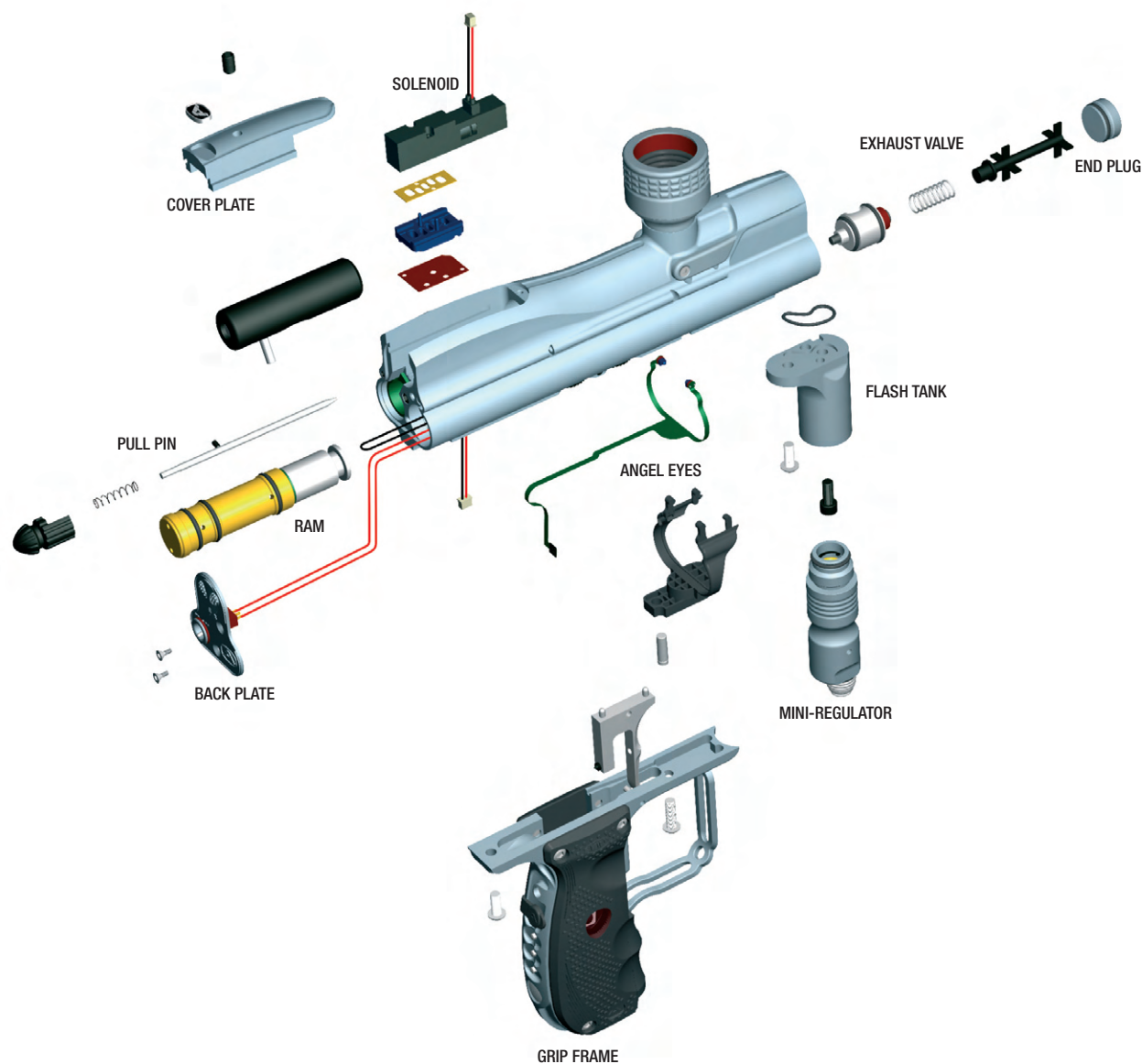

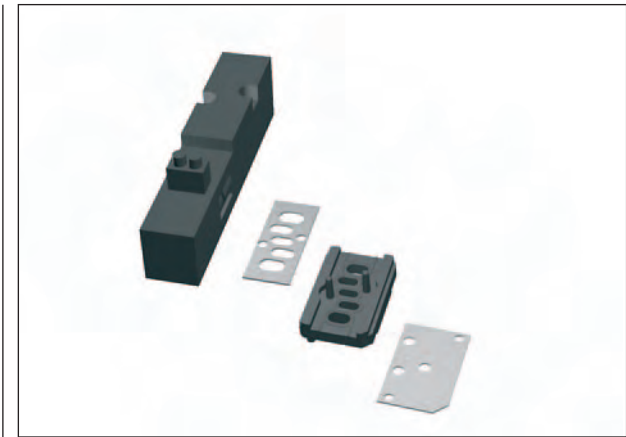

SOLENOID ASSEMBLY



ANGEL EYES SENSOR

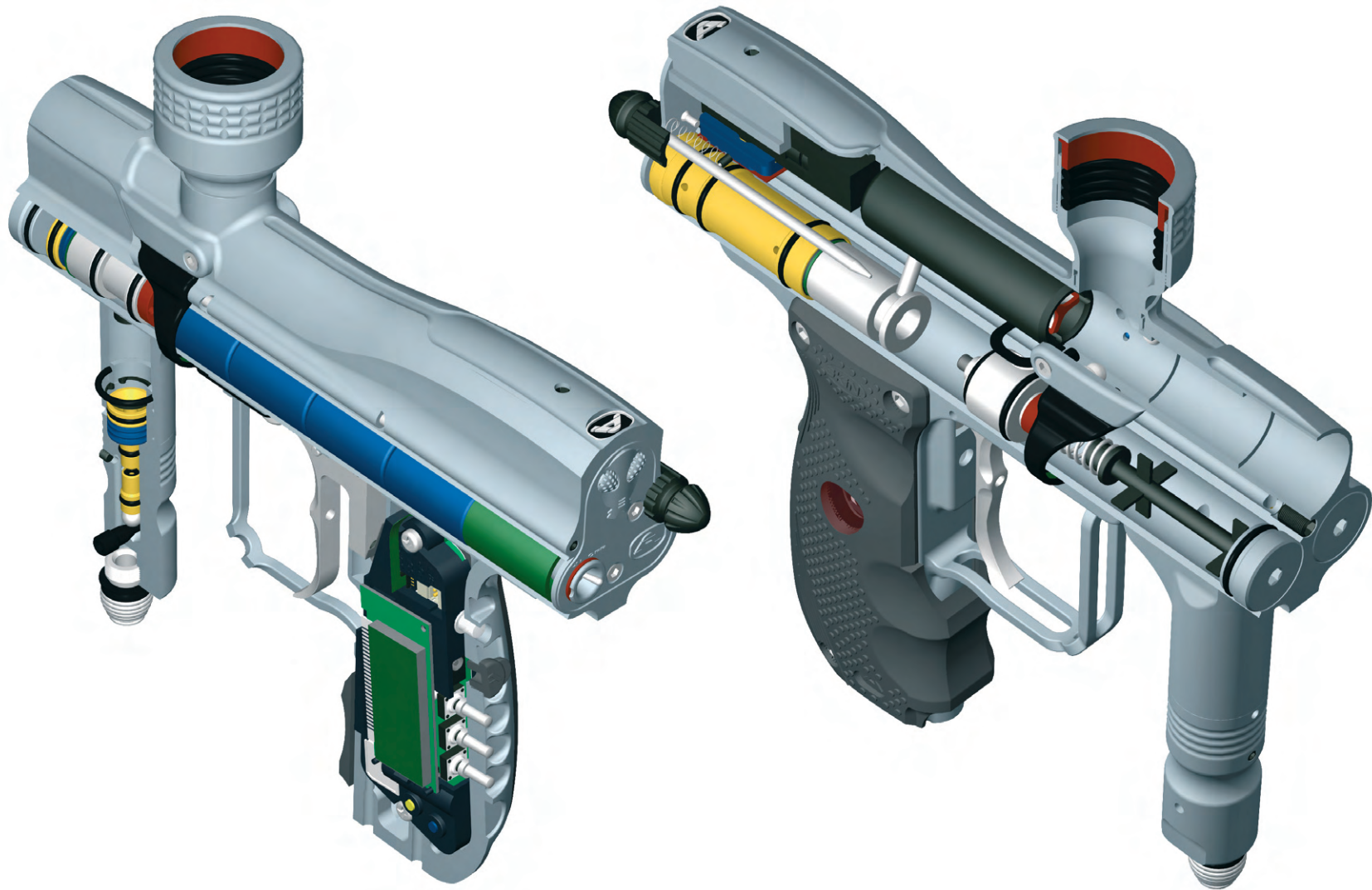

MINI-REGULATOR SERVICE

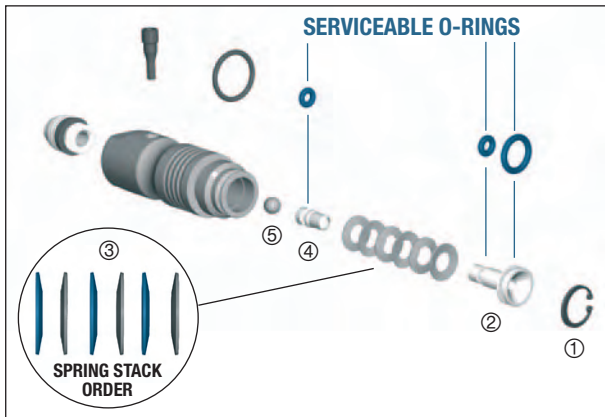

WARNING

ADHERE STRICTLY TO THESE AND ALL OTHER SAFETY INSTRUCTIONS AND GUIDELINES

- Ensure a barrel blocking device is fitted to the ANGEL.
- Ensure the hopper is removed from the ANGEL.
- Ensure that there are no paintballs in the ANGEL.
- Always remove the first stage regulator and relieve all residual gas pressure from the ANGEL before disassembly.
- The ANGEL can hold a small residual charge of gas, typically 2 shots, with the first stage regulator removed. Always discharge the marker in a safe direction to relieve this residual gas pressure.

The mini-regulator is a second stage regulator that is used to control the velocity and regulate the gas pressure. It can be deleted, but only if a suitable first stage regulator is used that incorporates a high flow and good regulation properties across the tank pressure range. The thread interface is to ASTM industry standard form.

- Remove the macro line hose from the mini regulator by following the procedure and warnings given in PROPELLANT AIR/NITROGEN SUPPLY - Page 4.
- Remove the mini-regulator from the flash tank by screwing counter-clockwise.
- Remove the circlip ① using circlip pliers.
- Invert the mini-regulator body and tap it down firmly onto a smooth surface to shock the internals out of the mini-regulator body.
- Ensure the large piston ②, Spring stack ③, small piston ④ and the ball bearing ⑤ are removed.
- Inspect the O rings for damage and replace if necessary.
- Inspect the small piston face seal for damage and replace the whole small piston ④ if necessary.
- Inspect the large piston ② and small piston ④ sealing faces for damage and replace if necessary.

IMPORTANT NOTES: For re-assembly of components

- Due care and attention must be shown to ensure you do not score or damage the bores within the mini-regulator body whilst performing maintenance.
- If the small piston or large piston seal faces are damaged they must be replaced.
- We recommend that you lubricate the parts during re-assembly with Love Juice Extreme Grease.
- Ensure the spring stack ③ is in the correct order.
- Ensure the circlip ① is re-located correctly in the groove.
- Ensure you follow the procedure and warnings given in PROPELLANT AIR/NITROGEN SUPPLY - Page 4, when re-attaching the micro-line hose.

ANTI-DOUBLE BALL DETENT SERVICE

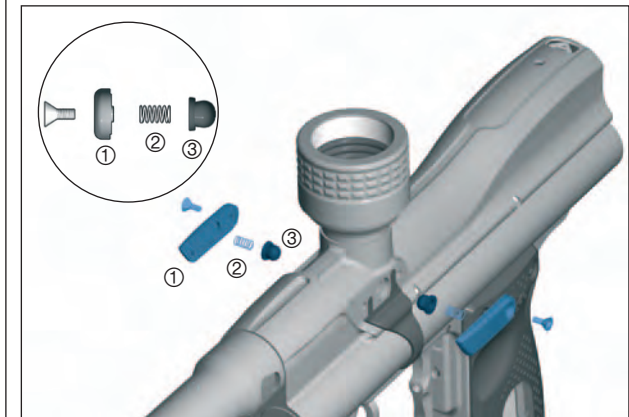

WARNING

ADHERE STRICTLY TO THESE AND ALL OTHER SAFETY INSTRUCTIONS AND GUIDELINES

- Ensure a barrel blocking device is fitted to the ANGEL.
- Ensure the hopper is removed from the ANGEL.
- Ensure that there are no paintballs in the ANGEL.
- Always remove the first stage regulator and relieve all residual gas pressure from the ANGEL before disassembly.
- The ANGEL can hold a small residual charge of gas, typically 2 shots, with the first stage regulator removed. Always discharge the marker in a safe direction to relieve this residual gas pressure.

There are two anti-double ball assemblies that can be removed and the internal parts serviced if necessary. These are located on either side of the body below the feed tube.

- Using a 2.0mm Allen key, remove the covers ①.
- Remove the spring ②.
- Remove the anti-double ball ③.
- Repeat for other side.
- Inspect parts and replace if necessary.

IMPORTANT NOTES: For re-assembly of components

- Ensure the anti-double ball ③ is re-located correctly.
- Ensure the spring ② is located correctly onto the anti-double ball.
- Ensure the anti-double ball covers ① are inserted correctly into the ANGEL body.
- Ensure that the Angel Eyes are not moved or trapped.

ANGEL EYES

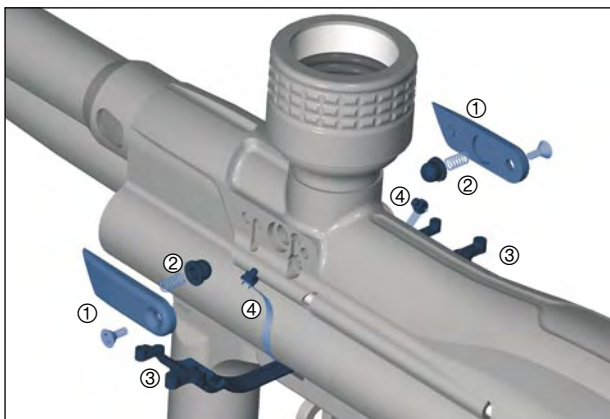

⚠ WARNING

ADHERE STRICTLY TO THESE AND ALL OTHER SAFETY INSTRUCTIONS AND GUIDELINES

- Ensure a barrel blocking device is fitted to the ANGEL.
- Ensure the hopper is removed from the ANGEL.
- Ensure that there are no paintballs in the ANGEL.
- Always remove the first stage regulator and relieve all residual gas pressure from the ANGEL before disassembly.
- The ANGEL can hold a small residual charge of gas, typically 2 shots, with the first stage regulator removed. Always discharge the marker in a safe direction to relieve this residual gas pressure.

The ANGEL uses a dual optical eye (break beam) system to detect when a ball is in position and ready to fire.

SERVICE

Prior to servicing the Angel Eyes you should carry out the Angel Eye test to ensure that they are not functioning prior to servicing. See Angel Eye Test - Right.

The Angel Eyes are located under the same cover plates as the anti double balls and the internal parts can be serviced if necessary. These are located on either side of the body below the feed tube.

- Using a 2.0mm Allen key, remove the covers ①.
- Remove the anti double ball assembly ②.
- Carefully remove the rubber protective strap from its location ③.
- Carefully extract the Angel Eye from its location hole and clean if necessary ④.
- Inspect parts and clean if necessary.

IMPORTANT NOTES: For re-assembly of components

- Ensure the anti-double ball is re-located correctly.
- Ensure the spring is located correctly onto the anti-double ball.
- Ensure the cover plates are inserted correctly into the ANGEL body
- Ensure that the Angel Eyes are not moved or trapped.

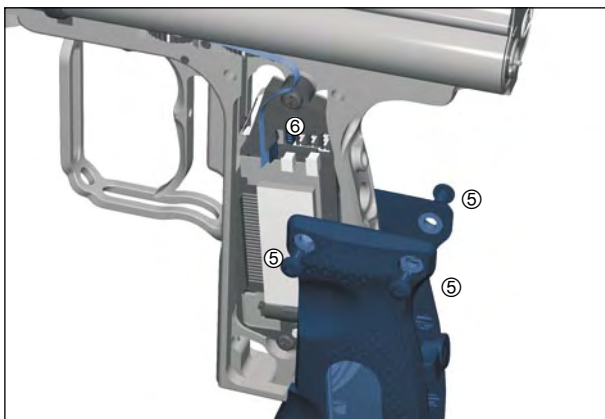

REMOVAL

The whole of the Angel Eyes system may be removed should it become damaged, should this prove necessary follow the procedure listed below;

- Remove the Angel Eyes from the body as per the service instructions.
- Remove the grip cheek screws using a suitable 2.5mm Allen Key ⑤.
- Carefully unplug the ribbon cable from the PCB ⑥.
- Carefully unplug all remaining plugs from the PCB ⑥.
- Remove the grip frame from the body using a suitable 3.0mm Allen Key ⑦.
- Remove the protective strap assembly from the body ⑧.
- Remove the vernier trigger wheels ⑨ See VERNIER TRIGGER WHEEL REMOVAL SECTION - Page 22.
- Carefully remove the Angel Eyes flexible PCB and replace if necessary ⑩.

TEST

- Whilst the ANGEL is in SAFE mode.
- From the Basic or Advanced menu select the Angel Eyes Test option, using the middle button externally or the blue button internally.
- Press the bottom button externally and the display will show dropB.
- Drop a paintball into the feed tube so that it falls into the breach.
- When the paintball is detected the display will give the message PASS.
- Repeat this several times to ensure the Angel Eyes are functioning correctly.
- Failure to obtain the PASS message can be an indication that the Angel Eyes need to be cleaned or replaced.

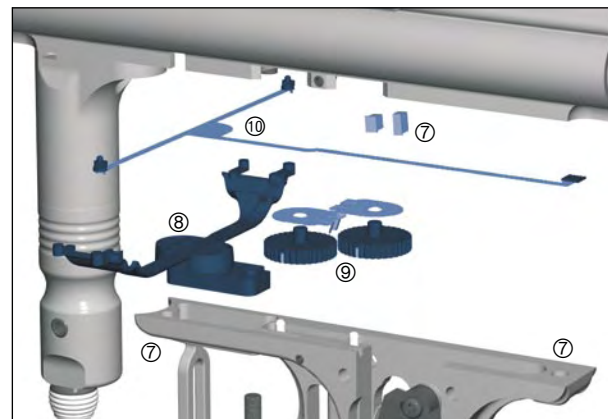

⚠ WARNING

ADHERE STRICTLY TO THESE AND ALL OTHER SAFETY INSTRUCTIONS AND GUIDELINES

- Ensure a barrel blocking device is fitted to the ANGEL.
- Ensure the hopper is removed from the ANGEL.
- Ensure that there are no paintballs in the ANGEL.
- Always remove the first stage regulator and relieve all residual gas pressure from the ANGEL before disassembly.
- The ANGEL can hold a small residual charge of gas, typically 2 shots, with the first stage regulator removed. Always discharge the marker in a safe direction to relieve this residual gas pressure.

SENSOR REPLACEMENT

- Remove the grip cheek cover by removing the 6 retaining screws and using a metric 2.5mm A/F Allen key.
- Unplug the battery and solenoid plugs ⑥.
- Remove the Angel Eyes ribbon cable from the ZIF socket on the circuit board ⑥.
- Ensure the vernier trigger wheels are locked.
- Remove the Anti double ball covers using a metric 2.0 mm A/F Allen key ①.
- Remove the 2 grip frame screws holding the frame to the body using a suitable 3mm A/F Allen key ⑦.
- Remove the grip frame from the body.
- Remove the Angel Eyes sensors and its shields from the body ⑧ ⑩.

IMPORTANT NOTES: For re-assembly of components

- Ensure no wires become trapped between the body and grip frame during re-assembly.
- Ensure the plugs are located in the correct sockets

MICRO PRESSURE INDICATOR (OPTIONAL)

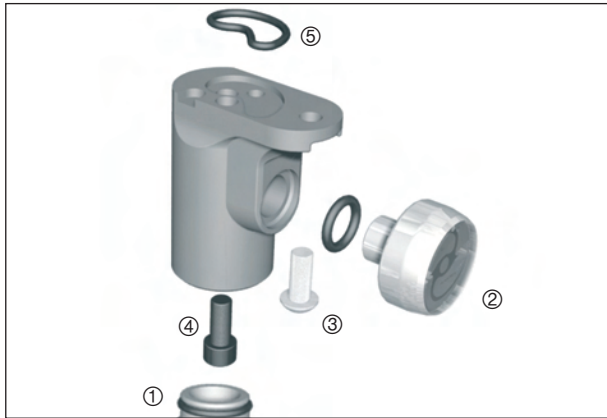

⚠ WARNING ADHERE STRICTLY TO THESE AND ALL OTHER SAFETY INSTRUCTIONS AND GUIDELINES

- Ensure a barrel blocking device is fitted to the ANGEL.
- Ensure the hopper is removed from the ANGEL.
- Ensure that there are no paintballs in the ANGEL.
- Always remove the first stage regulator and relieve all residual gas pressure from the ANGEL before disassembly.
- The ANGEL can hold a small residual charge of gas, typically 2 shots, with the first stage regulator removed. Always discharge the marker in a safe direction to relieve this residual gas pressure.

The micro pressure indicator is located above the mini regulator and is provided to give you the pressure that is being supplied to the ANGEL from the mini regulator. It is a non-serviceable item and should only be replaced with a genuine ANGEL micro pressure indicator.

- Unscrew by hand and remove the mini regulator ①.
- Removal of the micro pressure indicator ② is by hand by rotating counter clockwise.
- Remove flash tank external retaining screw ③ using a 3.0mm A/F Allen key.
- Remove the flash tank internal retaining screw ④ using a 4.0mm A/F Allen key.
- Ensure the flash tank O ring ⑤ is not lost.

IMPORTANT NOTES: For removal and re-assembly of components

- Do not apply any thread sealant to the micro pressure indicator threads.
- Do not expose the micro pressure indicator to pressures above 500 psi otherwise damage may occur and its readings will be incorrect.
- Do not use any form of grips or clamps on the micro pressure indicator body.
- Do not attempt to fit any other pressure indicator to the assembly.

LPR ADJUSTMENT

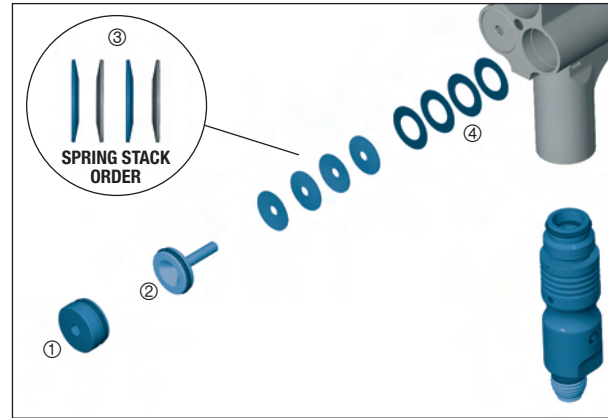

⚠ WARNING ADHERE STRICTLY TO THESE AND ALL OTHER SAFETY INSTRUCTIONS AND GUIDELINES

- Ensure a barrel blocking device is fitted to the ANGEL.
- Ensure the hopper is removed from the ANGEL.
- Ensure that there are no paintballs in the ANGEL.
- Always remove the first stage regulator and relieve all residual gas pressure from the ANGEL before disassembly.
- The ANGEL can hold a small residual charge of gas, typically 2 shots, with the first stage regulator removed. Always discharge the marker in a safe direction to relieve this residual gas pressure.

The low-pressure regulator controls the pneumatic cycle of the ANGEL and is located in the left-hand chamber at the front of the ANGEL body. The pressure needs to be at 82 PSI (5.7) output at a pressure of 350 PSI at the second stage regulator.

LPR adjustment is achieved by the removal of shims. Each shim equals approximately 5 PSI/0.35 BAR. We recommend the use of the optional service tools and lubrication of parts with Love Juice Extreme GREASE only. See General Assembly diagrams - pages 12-13.

- Ensure the ANGEL is de-gassed and switched OFF.
- Remove the left end cap ① using suitable metric 4.0 A/F Allen key.
- Insert the optional pressure gauge adaptor into the hole that the end cap ① was removed from.
- Re-Gas the ANGEL and switch the ANGEL to LIVE.

⚠ WARNING ADHERE STRICTLY TO THESE AND ALL OTHER SAFETY INSTRUCTIONS AND GUIDELINES

- THE ANGEL IS LIVE AND CAPABLE OF DISCHARGING.

- Fire 6 shots with NO paintballs present to stabilize the LPR pressure.
- Note the pressure reading. Should the reading be too high or low, proceed to the next stage.

⚠ WARNING ADHERE STRICTLY TO THESE AND ALL OTHER SAFETY INSTRUCTIONS AND GUIDELINES

- Always remove the first stage regulator and relieve all residual gas pressure from the ANGEL before disassembly.
- The ANGEL can hold a small residual charge of gas, typically 2 shots, with the first stage regulator removed. Always discharge the marker in a safe direction to relieve this residual gas pressure.

- Ensure the ANGEL is de-gassed and switched OFF.
- Remove the pressure gauge adaptor and insert an M 2.5mm screw or the piston extracting tool (optional extra) into the brass piston ② and withdraw slowly.
- Remove the four piston springs ③.
- Add or subtract shims ④ as necessary, note the number of shims may vary from the diagram shown (maximum 20).
- Replace piston springs ③ in correct order onto the piston.
- Re-insert the piston ② ensuring that it is located correctly.
- Insert the optional pressure gauge adaptor into the hole that the end cap ① was removed from.
- Re-Gas the ANGEL and switch the ANGEL to LIVE.

⚠ WARNING ADHERE STRICTLY TO THESE AND ALL OTHER SAFETY INSTRUCTIONS AND GUIDELINES

- THE ANGEL IS LIVE AND CAPABLE OF DISCHARGING.

Verify the LPR pressure by following the procedure described above. Once the desired pressure has been achieved proceed to the next stage.

⚠ WARNING ADHERE STRICTLY TO THESE AND ALL OTHER SAFETY INSTRUCTIONS AND GUIDELINES

- Always remove the first stage regulator and relieve all residual gas pressure from the ANGEL before disassembly.
- The ANGEL can hold a small residual charge of gas, typically 2 shots, with the first stage regulator removed. Always discharge the marker in a safe direction to relieve this residual gas pressure.

- Ensure the ANGEL is de-gassed and switched OFF.
- Remove the pressure gauge adaptor & replace the end cap ①.

LPR ASSEMBLY REMOVAL

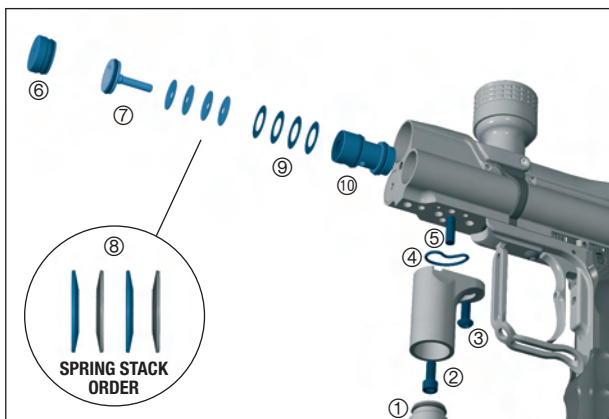
⚠ WARNING

ADHERE STRICTLY TO THESE AND ALL OTHER SAFETY INSTRUCTIONS AND GUIDELINES

- Ensure a barrel blocking device is fitted to the ANGEL.
- Ensure the hopper is removed from the ANGEL.
- Ensure that there are no paintballs in the ANGEL.
- Always remove the first stage regulator and relieve all residual gas pressure from the ANGEL before disassembly.
- The ANGEL can hold a small residual charge of gas, typically 2 shots, with the first stage regulator removed. Always discharge the marker in a safe direction to relieve this residual gas pressure.

- Unscrew and remove the mini regulator ①.
- Remove the flash tank internal retaining screw ② using a 4.0mm A/F Allen key.
- Remove the micro-pressure indicator if fitted (optional accessory).
- Remove flash tank external retaining screw ③ using a 3.0mm A/F Allen key.
- Ensure O ring ④ is not lost.
- Remove LPR retaining pin ⑤ using suitable grips.
- Remove the right end cap ⑥ using suitable metric 4.0mm A/F Allen key.
- Insert an M 2.5mm screw or the piston extracting tool (optional extra) into the brass piston ⑦ and withdraw slowly.
- Remove the 4 piston spring stack ⑧.
- Remove the shims ⑨, Note: the number of shims may vary from shown diagram.
- Using a suitable blunt pick, carefully withdraw the LPR body ⑩.

IMPORTANT NOTES: For re-assembly of components

- Care must be taken so that the bore is not scored or the seals damaged.
- Ensure the LPR's pin location hole is aligned with the pin retaining hole within the ANGEL body prior to insertion.
- Ensure the spring stack ⑧ is inserted in the correct order.
- We recommend that you verify your LPR pressure if it has been removed. See LPR ADJUSTMENT - Page 17.
- Ensure the end cap ⑥ is located correctly.
- Ensure the springs or shims are not lost (see LPR assembly). Insert or remove shims as necessary.
- Each shim equals approximately 5 PSI/0.35 BAR

LPR MAIN SEAL REPLACEMENT

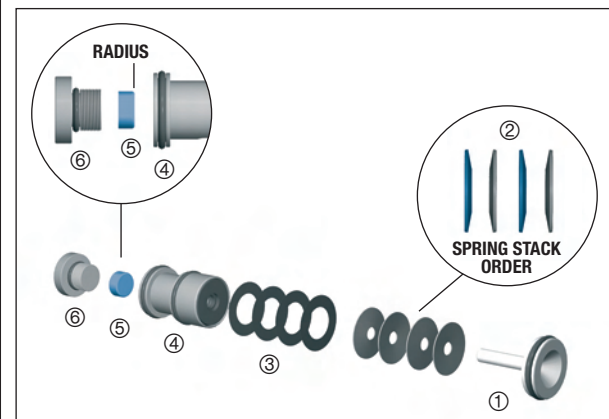
⚠ WARNING

ADHERE STRICTLY TO THESE AND ALL OTHER SAFETY INSTRUCTIONS AND GUIDELINES

- Ensure a barrel blocking device is fitted to the ANGEL.
- Ensure the hopper is removed from the ANGEL.
- Ensure that there are no paintballs in the ANGEL.
- Always remove the first stage regulator and relieve all residual gas pressure from the ANGEL before disassembly.
- The ANGEL can hold a small residual charge of gas, typically 2 shots, with the first stage regulator removed. Always discharge the marker in a safe direction to relieve this residual gas pressure.

The LPR may be serviced once it has been removed by following the LPR ASSEMBLY REMOVAL - Left. The serviceable parts are the external O rings and the internal main seal.

- Remove the LPR piston ①.
- Remove the LPR spring stack noting the order ②.
- Remove the LPR shims ③, Note: the number of shims may vary from shown diagram.
- Remove the LPR main seal retainer nut ⑥ from the LPR body ④ using a suitable tool. To prevent the body from rotating in your hand you may insert the LPR lock pin into the LPR body to give some leverage.
- Remove the main seal ⑤ noting the radius on the edge of the seal.
- Discard the main seal ⑤ and replace with new item.

IMPORTANT NOTES: For re-assembly of components

- Ensure the new main seal is replaced with the radius edge going in first.
- Ensure the seal retainer nut is tight and flush with the LPR body.
- Ensure the spring stack is in the correct order.
- Ensure that the LPR pressure is reset as per LPR ADJUSTMENT - Page 17.

EXHAUST GUIDE REMOVAL

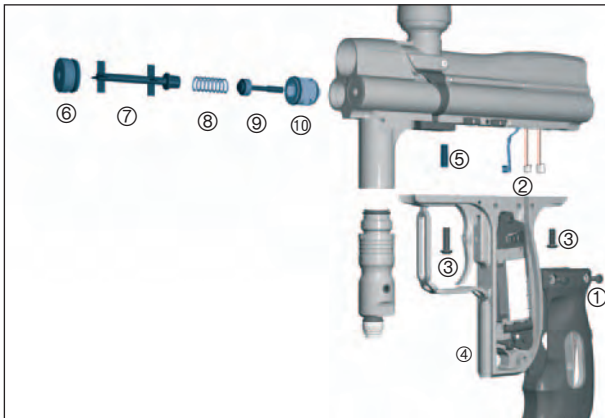

WARNING

ADHERE STRICTLY TO THESE AND ALL OTHER SAFETY INSTRUCTIONS AND GUIDELINES

- Ensure a barrel blocking device is fitted to the ANGEL.
- Ensure the hopper is removed from the ANGEL.
- Ensure that there are no paintballs in the ANGEL.
- Always remove the first stage regulator and relieve all residual gas pressure from the ANGEL before disassembly.
- The ANGEL can hold a small residual charge of gas, typically 2 shots, with the first stage regulator removed. Always discharge the marker in a safe direction to relieve this residual gas pressure.

- Remove the grip cheek cover by removing the 6 retaining screws ① using a metric 2.5mm A/F Allen key.
- Unplug the Angel Eyes, battery and solenoid plugs ②.
- Remove the 2 grip frame screws ③ holding the frame to the body using a suitable 3mm A/F Allen key.
- Remove the grip frame ④ from the body.
- Pull out the exhaust valve retaining pin ⑤ located in the body using suitable grips.
- Remove the left end cap ⑥ using suitable metric 4.0mm A/F Allen key.
- Remove the valve spring support bobbin ⑦.
- Remove the valve spring ⑧.
- Remove exhaust valve stem ⑨.
- Using a suitable blunt hooked pick carefully retract exhaust valve guide ⑩ by inserting the pick into the exhaust valve hole that the exhaust valve stem located into.
- Inspect and service parts as necessary.

IMPORTANT NOTES: For re-assembly of components

- Care must be taken so that the bore is not scored or the seals damaged.
- Ensure the exhaust valve guide body is free from damage that may score the bore.
- Ensure you do not damage the exhaust valve guide sealing face.
- Ensure the location hole in the exhaust valve guide is in the correct orientation to the lock hole within the main body prior to refitting.
- Slowly insert the valve guide pushing it down with a blunt soft faced rod.
- When the holes line up insert the lock pin into the hole.
- Ensure no wires become trapped between the body and grip frame during re-assembly.
- Ensure the plugs are located in the correct sockets.

EXHAUST VALVE STEM REMOVAL

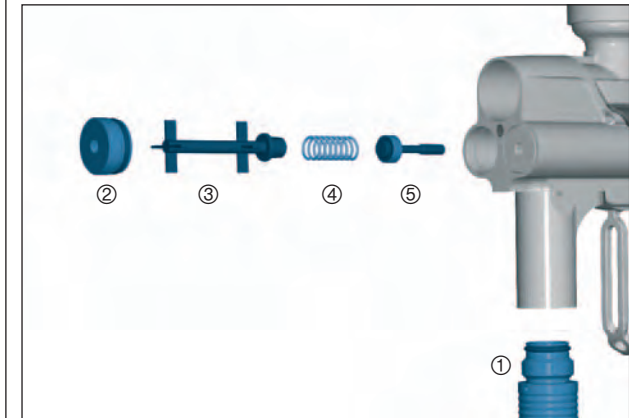

WARNING

ADHERE STRICTLY TO THESE AND ALL OTHER SAFETY INSTRUCTIONS AND GUIDELINES

- Ensure a barrel blocking device is fitted to the ANGEL.
- Ensure the hopper is removed from the ANGEL.
- Ensure that there are no paintballs in the ANGEL.
- Always remove the first stage regulator and relieve all residual gas pressure from the ANGEL before disassembly.
- The ANGEL can hold a small residual charge of gas, typically 2 shots, with the first stage regulator removed. Always discharge the marker in a safe direction to relieve this residual gas pressure.

The exhaust valve stem is a consumable item that will eventually wear out. Premature failure of the exhaust valve stem is caused by dirty air or failure to lubricate it at service intervals, to replace the exhaust valve stem follow the procedures listed below.

- Unscrew and remove the mini regulator ①.
- Remove the left end cap ② or volumizer using suitable metric 4.0mm A/F Allen key.
- Remove the valve spring support bobbin ③.
- Remove the valve spring ④.
- Remove exhaust valve stem ⑤.

IMPORTANT NOTES: For re-assembly of components

- Ensure exhaust valve is located in exhaust body within the ANGEL.
- Ensure the spring ④ is located onto the exhaust valve stem ⑤.
- Ensure the spring ④ is located onto the valve spring support bobbin ③.
- Ensure the end cap ② is located correctly

RAM STROKE ADJUSTMENT

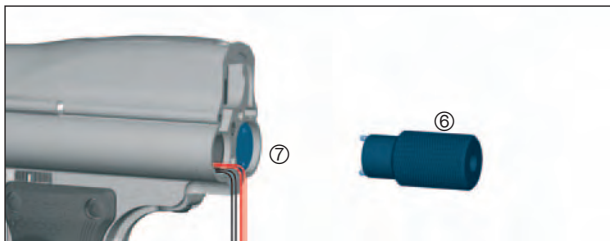
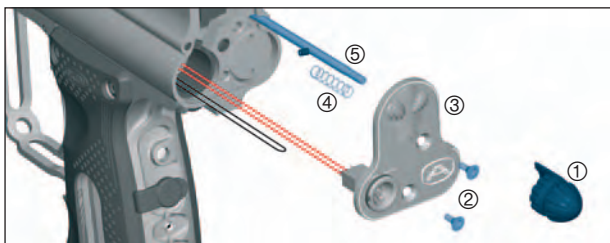

⚠ WARNING

ADHERE STRICTLY TO THESE AND ALL OTHER SAFETY INSTRUCTIONS AND GUIDELINES

- Ensure a barrel blocking device is fitted to the ANGEL.
- Ensure the hopper is removed from the ANGEL.
- Ensure that there are no paintballs in the ANGEL.

- Ensure the ANGEL is gassed and switched OFF.
- Ensure bolt is fully retracted.
- Remove the breech block pull knob ① by gently pulling and unscrewing counter-clockwise.
- Remove the countersunk screws ②, using a suitable 2.0mm A/F metric Allen key.
- Carefully lift the back plate ③ off.
- Retract the spring ④ and breech block lock pin ⑤.
- Using circlip pliers or the ram location tool ⑥ optional accessory rotate ram assemblies ⑦ clockwise until slight resistance is felt in opening the breech block. If rotated too far the breech will not open so rotate counter-clockwise and repeat operation. The ram must always be rotated clockwise when setting.

IMPORTANT NOTES: For re-assembly of components

- There are wires and a spring ④ is located under the back plate ③. Care must be taken so that the wires are not pulled or trapped during maintenance.
- The ram ⑦ must always be rotated clockwise when setting.
- Ensure the spring ④ is replaced correctly
- Ensure the breech block opens correctly after refitting the breech block knob ①.
- Ensure that no wires become trapped during re-assembly.

RAM REMOVAL

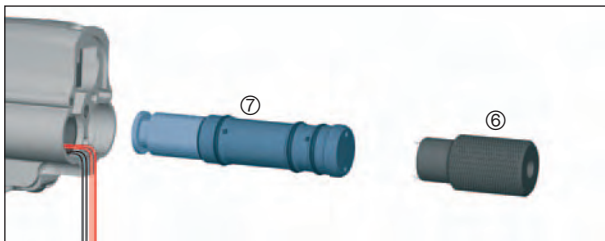
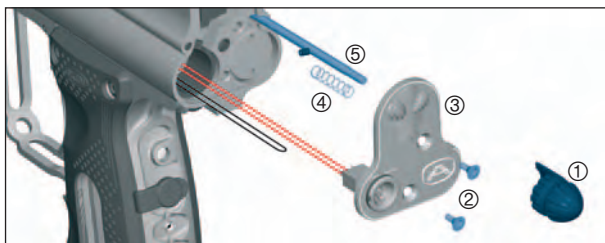

⚠ WARNING

ADHERE STRICTLY TO THESE AND ALL OTHER SAFETY INSTRUCTIONS AND GUIDELINES

- Ensure a barrel blocking device is fitted to the ANGEL.
- Ensure the hopper is removed from the ANGEL.
- Ensure that there are no paintballs in the ANGEL.
- Always remove the first stage regulator and relieve all residual gas pressure from the ANGEL before disassembly.
- The ANGEL can hold a small residual charge of gas, typically 2 shots, with the first stage regulator removed. Always discharge the marker in a safe direction to relieve this residual gas pressure.

- Ensure the ANGEL is de-gassed and switched OFF.
- Open the breech block and remove the bolt.
- Remove the breech block pull knob ① by gently pulling and unscrewing counter-clockwise.
- Remove the countersunk screws ②, using a suitable 2.0mm A/F metric Allen key.
- Carefully lift the back plate ③ off.
- Retract the spring ④ and breech block lock pin ⑤.
- Using circlip pliers or the ram location tool ⑥ (optional accessory) rotate ram assembly ⑦ counter clockwise and withdraw the ram.

IMPORTANT NOTES: For re-assembly of components

- There are wires and a spring ④ is located under the back plate ③. Care must be taken so that the wires are not pulled or trapped during maintenance.
- Ensure the ram assembly is lubricated with Love juice Extreme Grease prior to re-fitting.
- Ensure the ram assembly external O rings are not damaged.
- Ensure the ram assembly is inserted slowly to prevent damage to the O rings.
- See RAM STROKE ADJUSTMENT - Left, for setting the ram position.

RAM SERVICING

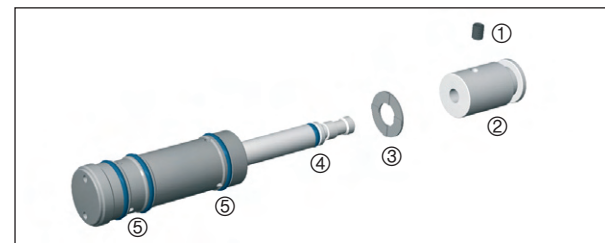

⚠ WARNING

ADHERE STRICTLY TO THESE AND ALL OTHER SAFETY INSTRUCTIONS AND GUIDELINES

- Ensure a barrel blocking device is fitted to the ANGEL.
- Ensure the hopper is removed from the ANGEL.
- Ensure that there are no paintballs in the ANGEL.
- Always remove the first stage regulator and relieve all residual gas pressure from the ANGEL before disassembly.
- The ANGEL can hold a small residual charge of gas, typically 2 shots, with the first stage regulator removed. Always discharge the marker in a safe direction to relieve this residual gas pressure.

- The ram must be removed as per RAM REMOVAL – Left, prior to servicing. The ram has three components that may be replaced these are the following: Hammer ②, Bumper ③, Ram clamp seal ④ and Ram Body O rings ⑤.
- Remove the ram hammer lock screw ① using a suitable 2.0 mm metric Allen key.
- Remove the hammer ② from the ram rod using suitable **SOFT** faced grips.
- Remove the bumper ③ and inspect for damage, replace if necessary.
- Remove the ram clamp seal ④ and replace.

IMPORTANT NOTES: For re-assembly of components

- The ram clamp seal ④ must be replaced with a new item if removed.
- We recommend that Loctite medium strength adhesive is applied to the hammer ② if removed.
- We recommend that Loctite medium strength adhesive is applied to the hammer lock screw ① if removed.
- We recommend that you lubricate the ram shaft with Love Juice Extreme Grease.

OPTO BOARD



WARNING

ADHERE STRICTLY TO THESE AND ALL OTHER SAFETY INSTRUCTIONS AND GUIDELINES

- Do not attempt to modify the OPTO™ board assembly in any way as this will invalidate your warranty and could lead to safety concerns.

The ANGEL incorporates the OPTO™ board. This is the latest development in trigger sensing function. It achieves unsurpassed advancements in trigger repeatability and sensitivity, its non-mechanical switching results in faster, shorter and lighter trigger strokes that give the user higher prolonged achievable rates of fire.

IMPORTANT NOTES:

- When accessing the Internal Tournament LED menus the OPTO™ board should not be exposed to direct sunlight or strong external sources of light without the grip cheek fitted as this light will induce a safety feature, that will prevent the ANGEL from firing whilst it remains exposed to the strong external light.
- The OPTO™ board is a non-mechanical switch that is silent in its operation and no audible click is present.

VERNIER TRIGGER ADJUSTMENTS

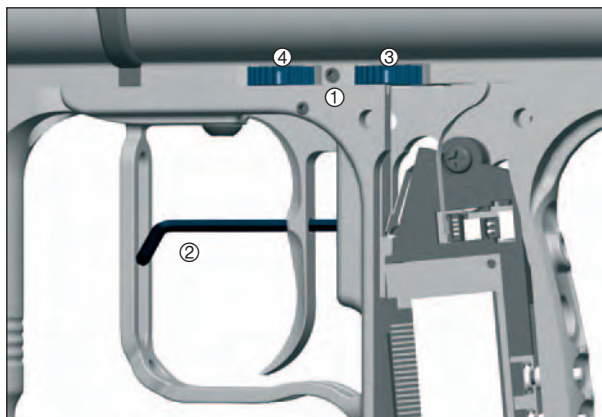

WARNING

ADHERE STRICTLY TO THESE AND ALL OTHER SAFETY INSTRUCTIONS AND GUIDELINES

- Ensure a barrel blocking device is fitted to the ANGEL.
- Ensure the hopper is removed from the ANGEL.
- Ensure that there are no paintballs in the ANGEL.
- Always remove the first stage regulator and relieve all residual gas pressure from the ANGEL before disassembly.
- The ANGEL can hold a small residual charge of gas, typically 2 shots, with the first stage regulator removed. Always discharge the marker in a safe direction to relieve this residual gas pressure.
- Never adjust your trigger so fine that accidental discharge can occur due to shock loads or vibration.

The trigger return stroke, over-travel and toe adjustments should be carried out in the order shown and will enable the user to have total adjustment on the tactile feel and trigger movement.

- Using a suitable Allen key undo the trigger adjustment locking screw ① located between the thumb wheels by rotating counter clockwise.
- Remove the grip cheek retaining screws and expose the circuit board
- Using a suitable Allen key back off the toe adjustment screw ② by rotating counter clockwise, now the trigger return stroke and over travel may be set.
- The vernier thumb wheel located at the top of the grip frame closest to the rear of the ANGEL ③ controls the over-travel
- By viewing the ANGEL on the left hand side of the body rotate the thumb wheel closest to the rear of the ANGEL slowly towards the rear of the ANGEL each click at a time, this will reduce the over travel each click will be an incremental reduction in the stroke.
- The vernier thumb wheel located at the top of the grip frame furthest to the rear of the ANGEL ④ controls the return stroke
- By viewing the ANGEL on the left hand side of the body rotate the thumb wheel furthest from the rear of the ANGEL slowly towards the rear of the ANGEL each click at a time, this will reduce the return stroke, each click will be an incremental reduction in the stroke.

- Further fine tuning can be achieved by adjusting the toe adjuster screw ②. Clockwise will cause the trigger to activate with less trigger movement counter clockwise will result in a longer trigger stroke within the limits set by vernier thumb wheels.
- Verify the trigger is functioning correctly.
- Replace grip cheek cover screws using a suitable metric Allen key.
- Very gently tighten the vernier thumb wheel locking screw

IMPORTANT NOTES: For re-assembly of components

- There must be sufficient over travel to activate the OPTO board, otherwise the opto-trigger will not operate correctly
- There must be sufficient return stroke to reset the OPTO board otherwise the opto-trigger will not operate correctly.
- Should the trigger be incorrectly adjusted, re-adjust the return stroke by repeating the procedures listed above or re-adjust the over travel by repeating the procedures listed above.
- When adjusting the trigger stroke we recommend you apply a small amount of Loctite low strength thread lock to the toe adjuster screw to prevent movement due to vibration prior to adjustment.
- The vernier locking screw must not be over tightened otherwise damage may occur to the vernier retention springs.
- The OPTO board is a non-mechanical switch that is silent in its operation and no audible click is present.
- The OPTO board should not be exposed to direct sunlight or external strong sources of light without the grip cheek fitted as this light will induce a safety feature, that will prevent the ANGEL from firing whilst it remains exposed to the external strong light.
- Never adjust the trigger stroke so that the trigger has so fine a movement that accidental discharges may occur or that trigger bounce may occur leading to accidental discharges.

VERNIER TRIGGER WHEEL REMOVAL

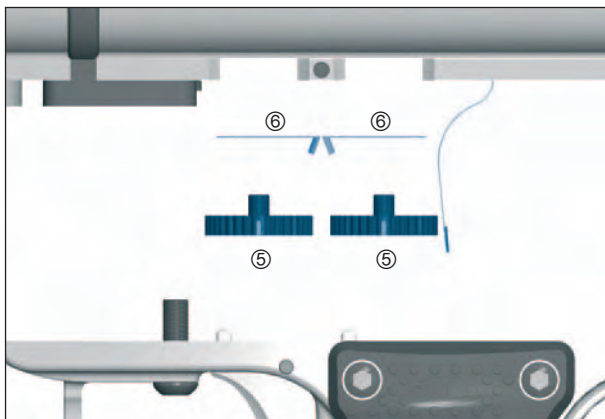
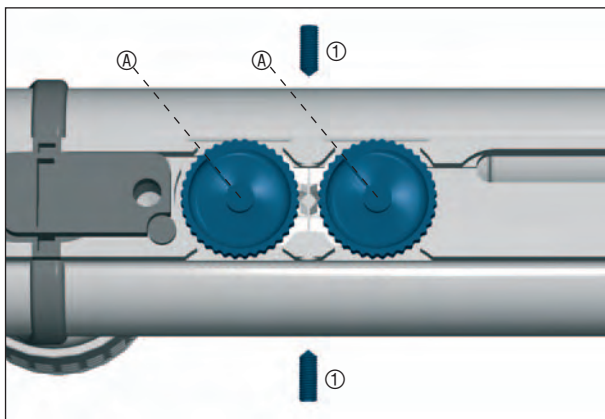
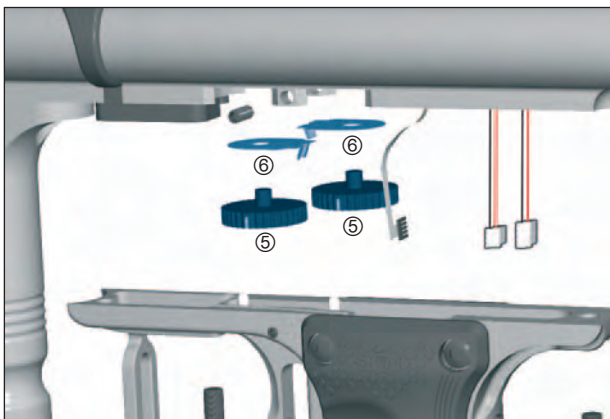
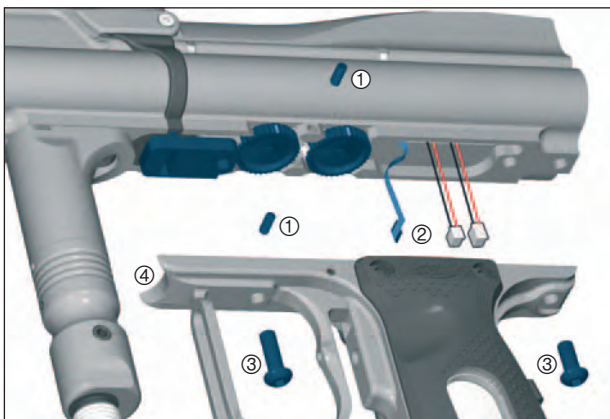

IMPORTANT NOTES: For re-assembly of components

- Should you be unsure of the original position of the vernier wheels follow the procedure listed below for re-assembly.
- Ensure the vernier wheel locking screws ① are backed off by rotating counter clockwise.
- Ensure the vernier trigger toe adjuster screw is backed off by rotating counter clockwise.
- It is important that the vernier wheels are inserted in position ① shown above, this is to ensure that you start with maximum range of adjustment
- Verify the correct vernier wheel position by the indicators on the wheels ⑤
- Re-attach the frame.
- Ensure no wires become trapped between the body and grip frame during re-assembly.
- Ensure the plugs are located in the correct sockets.
- Adjust the trigger as **VERNIER TRIGGER ADJUSTMENT** - Page 21.

⚠ WARNING

ADHERE STRICTLY TO THESE
AND ALL OTHER SAFETY
INSTRUCTIONS AND GUIDELINES

- Ensure a barrel blocking device is fitted to the ANGEL.
- Ensure the hopper is removed from the ANGEL.
- Ensure that there are no paintballs in the ANGEL.
- Always remove the first stage regulator and relieve all residual gas pressure from the ANGEL before disassembly.
- The ANGEL can hold a small residual charge of gas, typically 2 shots, with the first stage regulator removed. Always discharge the marker in a safe direction to relieve this residual gas pressure.
- Never adjust your trigger so fine that accidental discharge can occur due to shock loads or vibration.

- Undo the vernier wheel lock screws ① using a suitable allen key.
- Important: Note the vernier wheels position prior to removal.
- Remove the grip cheek cover by removing the 6 retaining screws and using a metric 2.5mm A/F Allen key.
- Unplug the Angel Eyes, battery and solenoid plugs ②.
- Remove the 2 grip frame screws ③ holding the frame to the body using a suitable 3mm A/F Allen key.
- Remove the grip frame ④ from the body.
- Gently remove the vernier wheels ⑤ from the body.
- Remove the vernier wheel ratchet plates ⑥ and inspect for damage.

BATTERY REMOVAL

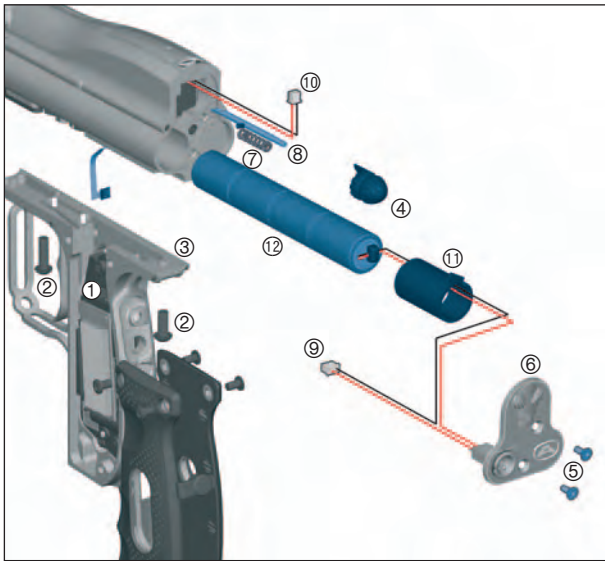

⚠ WARNING

ADHERE STRICTLY TO THESE
AND ALL OTHER SAFETY
INSTRUCTIONS AND GUIDELINES

- Ensure a barrel blocking device is fitted to the ANGEL.
- Ensure the hopper is removed from the ANGEL.
- Ensure that there are no paintballs in the ANGEL.
- Always remove the first stage regulator and relieve all residual gas pressure from the ANGEL before disassembly.
- The ANGEL can hold a small residual charge of gas, typically 2 shots, with the first stage regulator removed. Always discharge the marker in a safe direction to relieve this residual gas pressure.

The battery is a metal hydride 4.8 volt stick and is an item that will wear out with time dependant on the number of charges / discharges it has completed.

An indication of a worn battery is that it will not charge fully or that it will not hold a charge for a prolonged period. To replace the battery, follow the procedure below.

- Remove the grip cheek cover by removing the 6 retaining screws using a metric 2.5mm A/F Allen key.
- Unplug the Angel Eyes, battery and solenoid plugs from the PCB ①.
- Remove the 2 grip frame screws, ② holding the frame to the body using a suitable 3mm A/F Allen key.
- Remove the grip frame ③ from the body.
- Remove the breech block pull knob ④ by gently pulling and unscrewing counter-clockwise.
- Remove the countersunk screws ⑤ holding the back plate in place using a suitable 2.0mm A/F metric Allen key.
- Carefully lift the back plate ⑥ off.

- Retract breech block spring ⑦ and lock pin ⑧.
- Carefully feed the battery plug ⑨ and the solenoid plug ⑩ that was inserted into the PCB though the ANGEL body and withdraw the wires from the rear of the ANGEL.
- Remove the battery spacer ⑪ from the battery cavity.
- Carefully withdraw the metal hydride battery ⑫ from the ANGEL body.
- Re-assemble in reverse order.

IMPORTANT NOTES: For re-assembly of components

- Do not pull or apply excessive force to the wires.
- Do not trap any wiring or damage will occur to the wiring resulting in a fault developing.
- Do not attempt to disassemble the battery stick.
- Ensure that when the switch is replaced that it is rotated so that the ON position is as per the diagram in the section SWITCHING ON YOUR ANGEL - Page 3.

WIRING CONNECTIONS

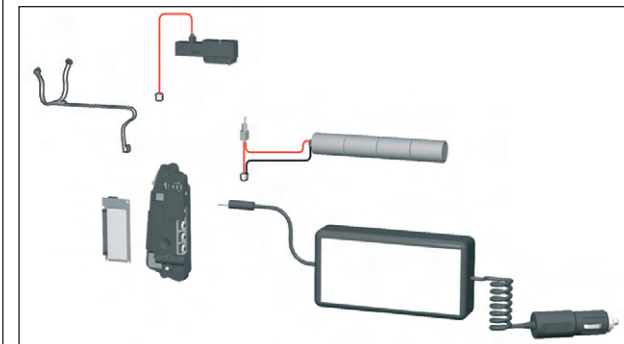
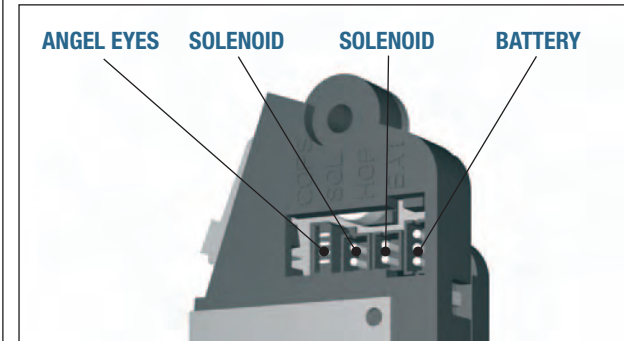

⚠ WARNING

ADHERE STRICTLY TO THESE
AND ALL OTHER SAFETY
INSTRUCTIONS AND GUIDELINES

- Ensure a barrel blocking device is fitted to the ANGEL.
- Ensure the hopper is removed from the ANGEL.
- Ensure that there are no paintballs in the ANGEL.
- Always remove the first stage regulator and relieve all residual gas pressure from the ANGEL before disassembly.
- The ANGEL can hold a small residual charge of gas, typically 2 shots, with the first stage regulator removed. Always discharge the marker in a safe direction to relieve this residual gas pressure.

- Ensure the ANGEL is de-gassed and switched off.
- Remove the left-hand side grip cheek cover by removing the 3 screws using a suitable metric Allen key.
- Access to the PCB connections is now gained.

IMPORTANT NOTES: For re-assembly of components

- Do not trap any wiring or damage could occur to the wiring resulting in a fault developing.
- Do not pull the plugs out from the PCB by the wiring use a suitable tool.

FAULT FINDING TABLE

PROBLEM	SOLUTION	PAGE
ANGEL WILL NOT FIRE		
No air or nitrogen present?	Propellant Air/Nitrogen Supply	4
Is the battery pack charged?	Charging the ANGEL	3
The battery is not charging.	Check vehicle voltage.	–
Is the ANGEL in 'SAFE'	Making the ANGEL 'LIVE'.	4
Is the isolator switched off?	Switching the ANGEL On.	4
Is the trigger not closing the switch?	Trigger Adjustment.	21
Is the trigger not releasing the switch?	Trigger Adjustment.	21
Is the bolt jammed forward?	Clear the blockage from breech.	–
Is the LPR set correctly?	LPR Adjustment.	17
Is the OPTO Trigger functioning?	Trigger Adjustment.	21
Are the connectors plugged in correctly?	Wiring Connections	23
Are the Angel Eyes switched on?	Ensure paint is present	–
Are the Angel Eyes optics blocked	Clean the Angel Eyes Optics	–

VELOCITY VARIATIONS

Are good quality paintballs been used?	Use good paintballs.	–
Is the barrel bore correct for the paint?	Use suitable barrel.	–
Is the paint swollen, cold or hot?	Review your storage of paint.	–
Is the barrel bore clean?	Clean the barrel.	–
Are the Anti-Double balls sticking?	Check Anti-Double Ball	15
Is the tank reg choking on gas supply?	Check tank regulator assembly.	4
Is the tank reg operating correctly?	Check tank regulator assembly.	4
Is the mini-reg operating correctly?	Mini-Regulator Service.	15
Is the mini-reg choking on gas supply?	Mini-Regulator Service.	15
Are unsuitable after market parts fitted?	Use genuine ANGEL parts.	–
Is the bolt worn?	Replace Soft Bolt.	5
Is the LPR set correctly?	LPR Adjustment.	17
Is the valve dwell set correctly?	Dwell Adjustment.	10
Is the ram set correctly?	Ram Stroke Adjustment.	20
Is first shot low?	Increase Dwell Time	10

VELOCITY TOO LOW / HIGH

Is the high pressure reg set correctly?	Check at Gas source.	4
Is velocity adjuster screw set correctly?	Velocity Adjustment.	6
Is the bolt sticking?	Check Anti-Double Ball.	15
Is the LPR set correctly?	LPR Adjustment.	17
Is the valve dwell set correctly?	Dwell Adjustment.	10
Is the Ram set correctly?	Ram Stroke Adjustment.	20

GAS LEAKING

From the back cover?	Check solenoid valve.	13
From the Ram assembly?	Check ram body O rings.	20
From the gas joints?	Check all fittings.	12-14
From exhaust valve?	Exhaust valve stem/guide.	19

PROBLEM	SOLUTION	PAGE
BREAKING PAINTBALLS		
Is the paint too fragile?	Use less fragile paint.	5
Is the barrel bore correct for the paint?	Use suitable barrel.	–
Is the paint swollen, cold, hot?	Review your storage of paint.	–
Are the Angel Eyes switched on?	Switching Angel Eyes On	4
Are the Angel Eyes functioning?	Angel Eyes Test.	16
Is the loader battery weak/dead?	Replace batteries.	5
Is a suitable working loader fitted?	See Loader section	5
Is the correct loader setting selected?	Change Loader Type settings	7
Is the rate of fire set too high?	MROF Adjustment.	9
Is the anti-double balls functioning?	Clean or replace.	15
Is the loader suitable for the paint?	Change paint colour	5
Is the paint too fragile for the loader?	Change paint to tougher grade	5

CHOPPING PAINTBALLS

Is the loader battery weak/dead	Replace batteries.	5
Is a suitable working loader fitted?	Replace loader.	5
Is the loader dirty?	Clean loader.	5
Are the paintballs swollen?	Replace the paintballs.	–
Are the Angel Eyes switched on?	Switching Angel Eyes On	4
Are the Angel Eyes functioning?	Angel Eyes Test.	16
Is the correct loader setting selected?	Change Loader Type settings	7
Is the Rate Of Fire set too high?	MROF Adjustment.	9
Are the Anti-double balls functioning?	Clean or replace.	15

FIRING TOO SLOW

Is the rate of fire set correctly?	MROF Adjustment.	9
Is the loader battery weak/dead?	Replace batteries	5
Is a suitable working loader fitted?	Replace loader	5
Is the loader dirty?	Clean loader	5
Are the Angel Eyes switched on?	Switching Angel Eyes On	4
Is the correct loader setting selected?	Change Loader Type settings	7
Is the Rate Of Fire set too low?	MROF Adjustment.	9

EXCESSIVE NOISE / GAS CONSUMPTION

Is the valve Dwell set correctly?	Dwell Adjustment.	10
Is the LPR pressure set correctly?	LPR Adjustment.	17
Is the exhaust valve worn?	Exhaust Valve replacement.	19
Is the barrel bore correct for the paint?	Use suitable barrel.	

USEFUL CONVERSIONS

Listed are some useful conversions relating to pressure, velocity, mass and distance.

PRESSURE

1 atm = 1.01325 bar
1 atm = 14.6959 psi
1 bar = 14.5038 psi
1 psi = 0.0689476 bar

VELOCITY

1 Ft/s = 0.3048 m/s
1 Ft/s = 0.6818180 Mph
1 m/s = 3.28084 Ft/s
1 m/s = 2.23694 Mph
1 m/s = 3.6 Kph

MASS

1 g = 0.05274 oz
1 Kg = 2.20462 lb
1 oz = 0.0283495 Kg

DISTANCE

1 mm = 0.0393701 Inch
1 Inch = 25.4mm
1 thou = 25.4 micron
1 micron = 0.0393701 thou

FORMULA TO CONVERT FEET PER SECOND (FT/S) TO FOOT LBS (FORCE)

1 foot lbs (force) = 1.35582 Joules
1 Joule = 0.737562 foot lbs (force)
1 Gram = 15.4324 Grains
1 Grain = 0.000142857 lb
1 lb = 7000 Grains

$$\frac{\text{Velocity squared} \times \text{Projectile weight}}{450240}$$

VELOCITY = Ft/s (feet per second)

PROJECTILE WEIGHT = GRAINS

Therefore a paintball @ 3.2grams @ 300Ft/s= 9.9 foot lbs (ftlbs)

TERMS OF WARRANTY - EEC/R.O.W. EXCLUDING USA / CANADA

Subject to the conditions set out below WDP Ltd. warrants that the ANGEL will correspond to its specification at the time of delivery and will be free from defects in materials and workmanship for a period of six months from the date of purchase.

WDP Ltd gives this warranty subject to the following conditions:

- Proof of purchase is required in all warranty claims.
- Warranty is not transferable.
- The company shall be under no liability in respect of any defect arising from fair wear and tear.
- Seals, batteries, wiring, circuit boards, displays and exhaust valves are not covered by this warranty. Wilful damage, negligence, abnormal working conditions, weather, accident, tampering, failure to follow manufacturers instructions (whether oral or in writing), misuse or alteration or repair of the ANGEL without the company's written approval will invalidate this warranty and the company shall be under no obligation whatsoever to the purchaser in respect of any of the above breaches of this warranty.
- The above warranty does not extend to parts, materials or equipment not manufactured by the company, in respect of which the purchaser shall only be entitled to the benefit of any such warranty or guarantee as given by the manufacturer to the company.

This warranty does not cover the following:

- Repairs, alterations or replacements not authorised by the manufacturer.
- The gradual reduction in performance linked to the age of the ANGEL or usage.
- Anything caused directly or indirectly by vandalism or theft.
- Any damage to parts which are recalled by the Manufacturer.
- Any loss, damage or failure, which a qualified engineer appointed by the Manufacturer, believes could have been avoided or was totally or partly caused by a lack of maintenance.

Subject as expressly provided in these conditions and except where the goods are sold to a person dealing as a consumer (within the meaning of the Unfair Contract Terms Act 1977) all warranties, conditions or other terms implied by statute or common law are excluded to the fullest extent permitted by law.

Where the goods are sold under a consumer transaction (as defined by the Unfair Terms in Consumer Contracts Regulations 1994 S13159) the statutory rights of the purchaser are not affected by these conditions. Carriage charges in relation to warranty claims shall be borne by the customer.

Where any valid claim in respect of the ANGEL is based in the quality or condition of the ANGEL or its failure to meet specification, and such valid claim is notified to the company in writing and is in accordance with the company's standard terms and conditions of sale, the company shall be entitled to repair or replace the goods or the part in question free of charge or, at the company's sole discretion, refund to the purchaser the price of the goods (or a proportionate part of the price) but the company shall have no further liability to the purchaser.

Except in respect of death or personal injury caused by the company's negligence, the company shall not be liable to the purchaser by reason of any representation, or any implied warranty, condition or other term, or any duty at common law, or under the express terms of this guarantee, for any direct or indirect, special or consequential loss or damage, whether to persons or property, costs, expenses or other claims for compensation or damages whatsoever (whether caused by the negligence of the company, its employees or agents or otherwise) which arise out of or in connection with the supply of the ANGEL its use, or misuse, or resale by the purchaser, or any individual, and the entire liability of the company under or in connection with the purchase or use or misuse of the ANGEL shall not exceed the purchase price of the ANGEL. Purchaser agrees to adhere strictly to all warnings and safety procedures and the contents of the Operators Manual.

The laws of England shall govern this warranty and the purchaser agrees to submit to the non-exclusive jurisdiction of the English courts.

The supply and purchase of the ANGEL is subject to the company's standard terms and conditions of sale, a copy of which is available on request. ANGEL patents applied for, design rights and all rights reserved. The ANGEL is marketed and distributed by WDP Ltd. company, registered in England No. 2114341.

No warranty is given to parts not manufactured by the manufacturer and all liability for loss damage or injury is excluded.

This warranty must be construed and read in conjunction with the products terms and conditions of sale.

To make a warranty claim, buyer must first contact the nearest authorised ANGEL Service Centre for instructions. A list of authorised ANGEL Service Centres may be obtained through WDP Ltd. website: www.wdp.tv, or by contacting WDP by mail at WDP Ltd., Metro Triangle, 221 Mount Street, Nechells, Birmingham, England, B7 5QT, or by fax at +(44) (0)121 327 3967, or by calling +(44) (0)121 328 2228.

WDP LTD. EXPRESS WARRANTY USA / CANADA ONLY

1. General Express Warranties.

WDP Ltd. warrants to the buyer who is purchasing to place into use (Buyer) only, that the ANGEL (Product) shall be free from material manufacturing defects in materials and workmanship for six months from the date of purchase, subject to the requirements, disclaimers and limitations of this Warranty. This is not a Warranty of performance, but a limited Warranty as to the condition of the Product at the beginning of the Warranty period, this Warranty is only against such defects and not against any other failures such as, but not limited to, those due to wear and tear, exposure to the elements, unusual operating environments, misuse, negligence, accident, alteration or repair in any respect which, in the judgement of WDP Ltd., adversely affects the condition or operation of the Product. Normal maintenance and perishable items such as seals, batteries, wiring, indicator lamps and exhaust valves are excluded from this limited Warranty against defects. This Warranty is not transferable and it may not be waived or expanded except in writing signed by WDP Ltd. The terms and limitations of this Warranty shall also apply to any additional goods or information, which may be distributed by WDP Ltd., relating to the ANGEL.

2. Disclaimer and Limitation of Express and Implied Warranties.

There are no express Warranties other than those contained in this Warranty. Whether or not the Product is to be used exclusively by Buyer, there shall be no third party beneficiaries to this Warranty herein. NO WARRANTY IS PROVIDED TO DISTRIBUTORS OR DEALERS EXCEPT AS MAY BE EXPRESSLY PROVIDED IN A SEPARATE AGREEMENT OF SALE. All descriptions, illustrations of the Product and other information in catalogues, brochures and price lists or otherwise provided by WDP or others are intended for general information only. WDP Ltd., is not responsible for any errors or omissions therein or for any loss or damage resulting from reliance on them. WDP Ltd., does not warrant that the Product is in compliance with any law or industry standards, guidelines or procedures. WDP Ltd. standard terms and conditions of sale also apply if Buyer is a direct purchaser from WDP Ltd. WDP LTD. DISCLAIMS ALL IMPLIED WARRANTIES INCLUDING, BUT NOT LIMITED TO, THOSE OF FITNESS FOR A PARTICULAR PURPOSE AND MERCHANTABILITY.

3. Remedy and Limitation of WDP Ltd. liability.

Defective or non-conforming Product or parts thereof discovered and returned to WDP Ltd. freight prepaid, with proof of purchase, during the Warranty period shall be repaired or replaced by WDP Ltd. without any additional charge and shipped to Buyer, FOB WDP Ltd. In lieu of repair or replacement, if WDP Ltd. elects, WDP Ltd. may, upon return of such product and making a determination of non-conformity or defect, keep the product and refund the purchase price paid by Buyer. Buyer's remedies shall be limited (even in the event of WDP Ltd. default of its Warranty obligations) exclusively to those provided in this Warranty. UNDER NO CIRCUMSTANCES SHALL WDP LTD. OR ANY SUPPLIER, DISTRIBUTOR, DEALER, OR OTHER PERSON BE LIABLE FOR EXEMPLARY, PUNITIVE, CONSEQUENTIAL OR INCIDENTAL DAMAGES, NOR FOR ANY AMOUNT IN EXCESS OF THE BUYER'S PURCHASE PRICE. Buyer waives any causes of action or theories of liability including, but not limited to, those arising under contract, tort, strict liability, Product liability, statutes, or otherwise, except as to those specifically provided by the Uniform Commercial Code (as adopted in Michigan) as excluded, modified and limited in this warranty.

4. Additional Consumer Protection.

The products are offered for sale for end use in supervised commercial establishments where professional safety codes are enforced, and not for personal, family or household use. Nevertheless, if the Product is determined in a transaction to be a customer Product under applicable law, the following provisions shall become applicable:

- (a) THE IMPLIED WARRANTIES OF MERCHANTABILITY OR FITNESS OF THE PRODUCT FOR A PARTICULAR PURPOSE THAT CANNOT BE DISCLAIMED ARE LIMITED IN DURATION TO THE INITIAL EXPRESS WARRANTY PERIOD.
- (b) Some states do not allow limitations on how long an implied Warranty lasts, so the above limitation in (a) may not apply.
- (c) Some states do not allow the exclusion or limitation of incidental or consequential damages, so such limitations may not apply.
- (d) And this Warranty gives buyer specific legal rights, and buyer may also have other rights provided for by law.

5. Parts, Service and Training performed by WDP Ltd.

All Warranty and non-Warranty parts, labour and service, if any, provided by WDP Ltd. related to the product are subject to all limitations and disclaimers of warranties and remedies provided in this Warranty. The replacement or repair of a product by WDP Ltd. does not give rise to any new Warranty except the Warranty period provided for herein shall be extended by the length of any period in which defective or non-conforming product is in possession of WDP Ltd. WDP Ltd. may have access to the Product after purchase of the Product. WDP Ltd. is not under any duty to inspect the product for any defects or any improper use or modification of the Product, nor to correct or advise anyone of any such condition, use or modification, which is observed. Any notification, which may be given, is voluntary and subject to all limitations and disclaimers in this Warranty.

6. User's Responsibility for Safety and Indemnification

It is Buyer's or other user's responsibility to obtain all training and means that may be necessary to effectively protect all individuals and property from damage and bodily injury, which otherwise may result from the use or maintenance of the Product, and to use the Product in accordance with operating instructions and due care.

If operating instructions are not provided with the Product or have been lost, a copy will be provided by WDP Ltd. without cost on request. Buyer shall use and shall require all others to use all safety devices and guards furnished with or intended to be used with the Product, and to follow proper safe operating procedures in accordance with general industry standards and as set forth in manuals and instruction information furnished by WDP Ltd. If Buyer fails to comply with the obligations set forth in this section, the buyer shall defend and indemnify WDP Ltd. harmless from any claim, liability or obligation incurred by WDP Ltd. or its suppliers, distributors, or dealers to persons injured directly or indirectly in connection with the use of the product contrary to this Warranty or any warning or instruction from WDP Ltd.

7. Law and Jurisdiction.

This Warranty shall be governed by the laws of Michigan, and Buyer irrevocably submits to the non-exclusive jurisdiction of courts sitting in Michigan to resolve all disputes arising from or related to this warranty or use of the Product.

8. Claims and information procedure.

To make a warranty claim, Buyer must first contact the nearest authorised ANGEL Service Centre for instructions. A list of authorised ANGEL Service Centres may be obtained through WDP Ltd. website: www.wdp.tv, or by contacting WDP Ltd. by mail at WDP Ltd., Metro Triangle,

221 Mount Street, Nechells, Birmingham, England, B7 5QT, or by fax at 011 44 121 327 3967, or by calling 011 44 121 328 2228.

UPDATES

The specification and photographs in this material are for general guidance purposes only.

Our products are continuously updated and changes may be made to specifications, design, or appearance from time to time.

For the latest specification, virtual products and on line technical support we recommend that you visit our website: www.wdp.tv.

YOUR PERSONAL DETAILS

Completing these details upon purchase will enable us to help you with your enquiries.

PURCHASE DETAILS

MODEL/COLOUR

BODY/BLOCK SERIAL NO

UNIQUE ELECTRONIC ID NO.

PURCHASED FROM

DATE

STREET

CITY

STATE

COUNTRY

ZIP/POSTCODE

PHONE

YOUR DETAILS

NAME

STREET

CITY

STATE

COUNTRY

ZIP/POSTCODE

PHONE

--	--

ANGEL™

⚠ WARNING

The ANGEL™ FLY is not a toy. Careless or improper use, including failure to follow the instructions in the Operator's Manual, could cause death or serious injury. Paintball industry standard eye/face/ear and head protection, designed specifically for paintball games, must be worn by user and any persons within range. Do not shoot at a person at close range. Must be at least 18 years of age to purchase. Persons under 18 years of age must only use under adult supervision. Observe all local laws, regulations and guidelines. Use only on professional paintball fields where codes of safety are strictly enforced.

Do not use CO2. Use .68 calibre paintballs only.

Read Operator's Manual before use and comply with all safety instructions AND guidelines.

The specifications & photographs in this manual are for information and general guidance purposes only. Our products are continually updated and changes may be made to specification, design or appearance from time to time. These changes are subject to change without notice. Contents of box may therefore vary from script or illustrations. For details of changes in design, specification or appearance consult your local distributor or dealer.

ANGEL™ is a registered trade mark. Design rights, copyrights and all rights reserved. All patterns, drawings, photographs, instructions or manuals remain the intellectual property of the manufacturer.

U.S. Patents: 6 003 504, 6 138 656, 6 311 682, 6 615 814, D473 910,
G.B. 2 342 710, 2 345 953, 2 372 553, 2 373 311, 2 384 292, 2 375 384,
2 352 022 plus other patents pending.

Registered Design Numbers. 2 106 442, 2 106 443.

All rights will be strictly enforced.

THE ANGEL™ FLY IS MADE IN ENGLAND AND MARKETED BY:

WDP LIMITED METRO TRIANGLE 221 MOUNT STREET

NECHELLS BIRMINGHAM B7 5QT ENGLAND

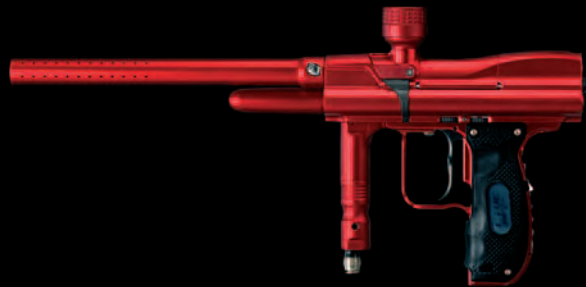

WDP Ltd,
Metro Triangle, Nechells, Birmingham,
England B7 5QT. Tel: +44 (0)121 328 2228.

WDP Paintball Inc.
417 Main, Huntington Beach,
CA 92648. Tel: (714) 536 9011.

