

!WARNING!

IMPORTANT SAFETY INSTRUCTION AND GUIDELINES

- This Paintball Marker is NOT A TOY. Misuse can cause serious injury or death.
- Recommend 18 years or older to purchase this product. Person under 18 must have adult supervision.
- Read this manual, understand and follow the manual instructions for using this product.
- Eye and face protection specially designed for paintball use, must be worn by user and persons within range at all times.
- Treat all paintball markers as if it were loaded and able to fire.
- Never look down the barrel or breech area of a marker.
- Always use barrel blocking device when the marker is not in use.
- Always chronograph this marker before playing paintball.
- Never shoot any marker at velocities exceeds 300 FPS (Feet Per Second), or velocities which is greater than local fields or national laws allow.
- Ensure all air lines and fittings are tightened and secured before installing the air tanks.
- Do not shoot at people, animals, houses, cars or anything is not related to the sport of paintball.
- Always keep the marker in Safe mode until ready for use.
- Fire only 0.68 caliber paintballs with this marker.
- Always make sure the bolt is in the un-cocked position when marker is not in use.
- Any modifications or tampering of original factory parts will cause all warranties and liabilities from Azodin.
- This owner's manual should always accompany this marker for reference and in the event of resale and new ownership.

!WARNING!

IMPORTANT CO2/ HPA AIR TANK SAFETY INSTRUCTION AND GUIDELINES

- Tank valves must be installed or removed by qualified personnel.
- All tanks must be retested before the expiration date.
- Improper use, filling, storage of this air tank may cause death, serious injury and property damage.
- Air tanks must be filled only by properly trained personnel.
- Do not over pressurize. Do not expose pressurized tanks to temperatures in excess of 130F° degrees (54°C).
- Do not expose tanks to corrosive materials and do not clean with caustic cleaners.
- Do not alter tanks in any way.
- Tanks heated up to a temperature of 250F° degrees (54°C) or more must be condemned or re-qualified.
- Keep air tanks out of reach of children.
- The valve should NEVER detach from the tank canister. Should this occur, seek assistance from a qualified airmith immediately.
- Air tanks are use for the sport of paintball only.

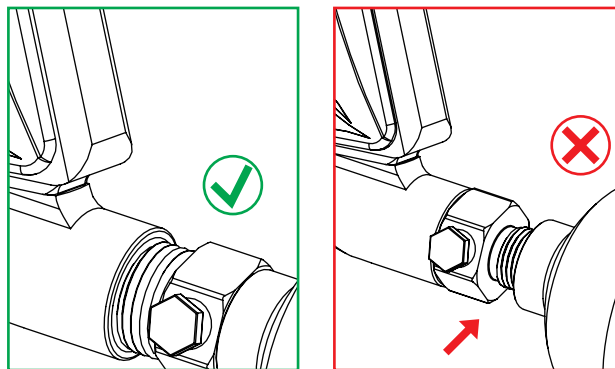

STOP IMMEDIATELY

When removing the air tank from the marker, check to see if the regulator / bonnet is unscrewing from the tank. If so, stop unscrewing the air tank from the marker and contact a qualified airmith for further assistance.

Air tanks should unscrew from the marker's ASA when the tank is turned counterclockwise. The regulator / bonnet should stay on the tank during the removal process.

HPA / N2 air tanks store high pressure air. If this air is released without using a regulator, it may cause serious injury or death.

GETTING STARTED

1. First, place the BARREL BLOCKING DEVICE over the barrel.
2. Always point the marker in a "SAFE" direction when powering it on. To turn the marker on, press the top button once. The marker will show a Red Light on the upper LED indicating it is in Safe Mode. The marker will not fire when the trigger is pulled. In order to remove the Safe Mode, please press the bottom button once. The upper Led will change to a Green Light (Eyes On) and the marker is ready to fire.
* For a detailed breakdown of the electronics and its operation, please refer to page (7)
3. Firmly screw in the CO2/ HPA/ N2 air tank onto the marker's ASA. Turn the air tank all the way in by turning it clockwise. CAUTION: Never use any hand tool to screw air tank to the bottom ASA.
4. Attach a paintball hopper/ loader to the marker's feed neck.
5. Remove the barrel blocking device and unlock the safe mode. CAUTION: The marker is now LIVE, pulling the trigger will fire a paintball. Only test the marker at a proper paintball field or in a safe direction where persons are not present.
6. Check the marker's velocity using a chronograph. Turning the Velocity Adjuster (P023) clockwise will increase the velocity. Turning it counterclockwise will decrease the velocity.
7. After playing, remove all paintballs from the hopper and detach the hopper from the marker. CAUTION: There may be 1-2 paintballs in the breach area. Shoot the marker until it is clear of paintballs or turn the marker upside-down to remove the paintballs.
8. Place the barrel blocking device over the barrel and turn the marker off. To turn the marker off, press and hold the top button until the lights disappear.
9. Unscrew the CO2/ HPA/ N2 air tanks from the marker's bottom ASA. CAUTION: Never use any hand tool to screw air tanks to the bottom ASA.
10. Store the marker in a paintball bag or in a safe place.

USING THE ZEN BOARD

TURNING ON THE BOARD: Press the Top Button once to turn on the board. The upper LED will show a Red Light (Safe Mode) and the Lower LED will show a Green Light (Default setting is Semi-Auto mode). If the Upper LED is flashing Red, the battery has a low charge and needs to be replaced. The Battery power status can be verified by press the Top Button once more.

SAFE MODE: After turning on the board, press the Lower Button once to turn off the Safe Mode. The Upper LED will show a Green Light to indicate the Eyes are on. Press the Lower Button again to turn on the Safe Mode. The Upper LED will revert back to the Red Light to indicate the Safe Mode is on.

EYES ON/OFF: When the Safety is off and Upper LED will show a Green Light (Eyes On). Pressing the Top Button once will change the Upper LED to an Orange Light indicating that the eyes are off.

To turn the eyes back on, press the Top Button again. The Upper LED will show a Green Light indicating the Eyes are on.

If the Eyes become blocked by paint or the Delrin Bolt (P042), the Upper LED will Flash Green. Pressing the Top Button twice will reset the Eyes back to a Solid Green Light. If the Upper light continues to Flash Green, clean out the Eyes and check to see if there is something blocking them.

FIRE MODE LOCK: To lock the marker in the desired fire mode, a Red Circuit Jumper needs to be removed from the Circuit Board. The Circuit Board will turn on with the last fire mode used when the "Jumper" is removed. When the jumper is on the Circuit board, the marker will power on with the default Green Mode (Semi-Auto). To re-enable all firing modes, simply place the Circuit Jumper back onto the Circuit Board.

LED COLORS
UPPER LED
RED = SAFF MODE
GREEN = EYES ON
ORANGE = EYES OFF (10.5 BPS)
FLASH RED = LOW BATTERY POWER STATUS
FALSH GREEN = EYES MALFUNCTION (8 BPS)
LOWER LED
GREEN = SEMI - AUTO (20 BPS SS=0)
DARK BLUE = PSP RAMP (10.2 BPS SS=3)
PURPLE = MILLENIUM RAMP (15 BPS SS=0)
LIGHT BLUE = CFOA SEMI (10.2 BPS SS=3)
FALSH GREEN = PROGRAMMING MODE

NOTE: Safety Shot (SS) defines the number of consecutive trigger pulls that must be achieved in order to activate the fire mode.

BUTTONS
TOP BUTTON
PRESS ONCE = POWER ON
PRESS AGAIN = VERIFY BATTERY POWER STATUS
PRESS AGAIN = EYES ON/OFF
PRESS AND HOLD = TURN OFF
LOWER BOTTON
PRESS ONCE = SAFF MODE ON/OFF
PRESS AND HOLD = ENTERS PROGRAMMING MODE
IN PROGRAMMING MODE
PRESS ONCE = CYCLE THROUGH SHOOTING MODES
PRESS AND HOLD = CONFIRM SHOOTING MODES

VELOCITY ADJUSTMENTS

(INCREASE & DECREASE VELOCITY)

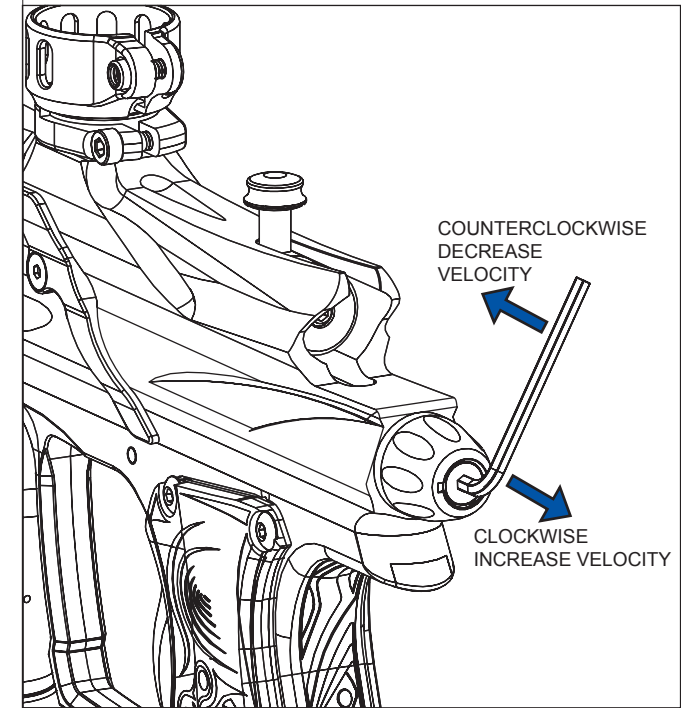

To increase your velocity FPS (Feet Per Second), use the allen wrench to turn the Velocity Adjuster (P023) clockwise.

To decrease your velocity FPS (Feet Per Second), use the allen wrench to turn the Velocity Adjuster (P023) counterclockwise.

ASSEMBLY AND CLEANING

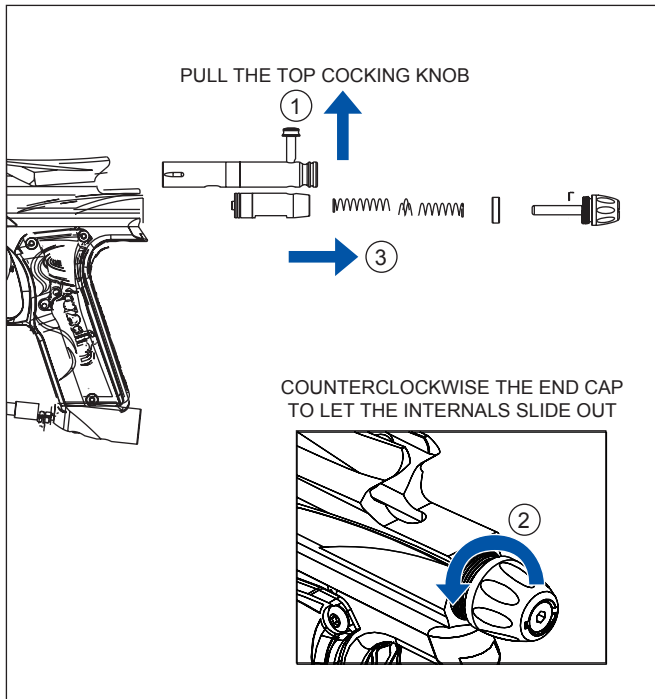

WARNING: Never remove the internals of the marker while the air tank is attached with the marker. Always remove all paintballs, loader and air tank before disassembling the marker.

MAINTAINING THE REAR INTERNALS

1. Lift the Top Cocking Knob, at the rear of the bolt, and slide the Delrin Bolt (P042) out the back.
2. Turn the End Cap (A051) counterclockwise and remove it from the marker.
3. Remove the Feather Striker Spring (P022) and the Bumper (P024) from the lower receiver.
4. Tilt the marker back and slide the Feather Striker (P021) out of the lower receiver.
5. Use a squeegee and/or battle swab to clean the inside of the receiver. Wipe down the bolt and striker for paint and/or dirt.
Apply a thin coat of paintball grease (Dow 33 based) to the Striker O-ring (R015) after each day of play.

REASSEMBLING THE REAR INTERNALS

1. Turn the marker on and set the board to eyes off mode.
2. Insert the Feather Striker (P021) with the oring facing towards the front of the marker. While inserting the Feather Striker, apply pressure behind it and pull the trigger. This will allow the striker clear the sear and move forward.
3. Insert the Delrin Bolt (P042) through the rear of the receiver.
Align the bolt with the Feather Striker and push the Cocking Knob down so it makes contact with the Feather Striker. The Top Cocking Knob should pass through hole on the top of the Feather Striker. If they made a connection, both pieces will move together when the bolt is pushed back and forth.
4. Insert the Feather Bumper (P024) into the lower receiver.
5. Insert the Feather Spring (P022) through the Feather Bumper (P024).
6. Insert the End Cap (A051), with the Velocity Adjuster (P023), through the Feather Spring.
7. Turn the End Cap (A051) clockwise until it is flush with the receiver. This cap will hold the internals in place.

TROUBLESHOOTING

WARNING: Always remove all paintballs, loader and air tank before disassembling the marker.

RECOCKING ISSUES

Striker O-Ring (R011) needs to be lubricated with Dow 33 Grease or Azodin Team Lube.

Striker O-Ring is damaged, missing, or incorrect. Replace with correct O-ring.

Pressure in the tank is too low and needed to be refilled.

Dirt and/or broken paintballs shells fragments in the receiver.
Disassemble the rear internals and clean out the receiver.

AIR LEAKS





Air leaking from the low pressure chamber. Check Front Valve O-Ring (R012), replace the O-ring and apply a thin coat of lube to the O-ring.

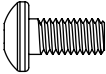

Air leaking from under the barrel is normally caused by worn or damaged Cup Seal (PH13). Check the guide for removal of Cup Seal / Valve Body. A scratch on the Valve Body will cause air leak.

A scratch on the Valve Body will cause air leak.

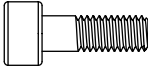
Air leaking from the receiver and throughout the Grip frame. Check Valve O-Rings and replace.

For a thorough breakdown visit our website or our [YouTube](#) channel AzodinPB.

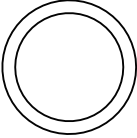
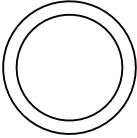
BLITZ-III SCREW CHART SIZE: 1:1	PART NUMBER AND NAME
	S011 M5 X 10L MAIN BODY SCREW
	S012 M8 X 8L VALVE RETAINING SCREW
	S016 M4 X 8L GRIP PANEL SCREW
	S017 M5 X 14L VERTICAL ASA SCREW
	S018 M4 X 8L EYE COVER SCREW
	S031 M4 X 4 RETAINING SCREW

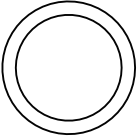
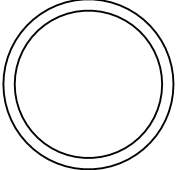
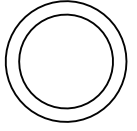
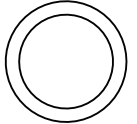
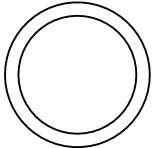
BLITZ-III O-RING CHART SIZE: 1:1	PART NUMBER AND NAME
	R009 NO.9 O-RING (BROWN)
	R011 STRIKER O-RING (RED)
	R012 FORNT VALVE O-RING (CLEAR)
	R013 VELOCITY ADJUSTER O-RING (BLACK)
	R015 AZ O-RING (BLACK)
	R016 BARREL O-RING (BLACK)
	R017 END CAP O-RING (BLACK)
	R031 REGULATOR PISTON O-RING (CLEAR)
	R032 REGULATOR SWIVEL MOUNT O-RING (BLACK)

A063 INLINE REGULATOR

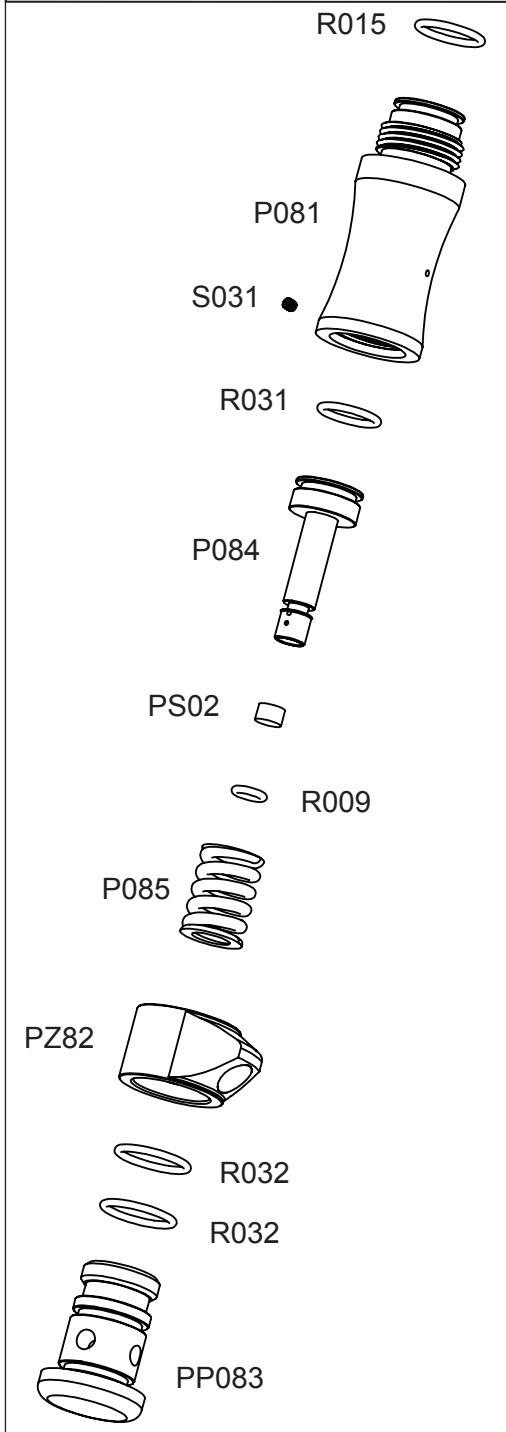

REGULATOR PARTS LIST

NO	PART NAME
PS02	PISTON SEAT
P081	MAIN REGULATOR HOUSING
PZ82	REGULATOR SWIVEL 45 MOUNT
PP083	REGULATOR END CAP
P084	REGULATOR PISTON
P085	REGULATOR MAIN SPRING
R009	NO.9 O-RING (BROWN)
R015	AZ O-RING
R031	REGULATOR PISTON O-RING
R032	REGULATOR SWIVEL MOUNT O-RING
S031	RETAINING SCREW

BLITZ PARTS LIST

NO	PART NAME	NO	PART NAME
PH11	HP VALVE	R015	AZ O-RING
PH12	HP CUP SEAL STEM	R016	BARREL O-RING
PH13	HP CUP SEAL	R017	END CAP O-RING
P014	CUP SEAL GUIDE	S011	MAIN BODY SCREW
P015	VALVE SPRING	S012	VALVE RETAINING SCREW
P021	FEATHER STRIKER	S013	BOTTOM ASA SCREW
P022	FEATHER SPRING	S016	GRIP PANEL SCREW
P023	VELOCITY ADJUSTER	S017	VERTICAL ASA SCREW
P024	FEATHER BUMPER	S018	EYE COVER SCREW
P031	BALL DETENT	A012	BLITZ BODY
P033	EYE COVERS	A021	BOTTOM ASA
P042	BOLT ASSEMBLY	A032	VERTICAL ASA
P073	BRAIDED HOSE	A041	FRONT PLUG
SLF1	SCREW LOCK FEEDNECK	A051	END CAP
R011	STRIKER O-RING (RED)	A063	PRESET REGULATOR
R012	FRONT VALVE O-RING (CLEAR)	A073	NYLON E-GRIP FRAME ASSEMBLY
R013	VELOCITY ADJUSTER O-RING	A082	GRIP PANEL
		A201	12" BARREL

BLITZ-III EXPLODED VIEW

