

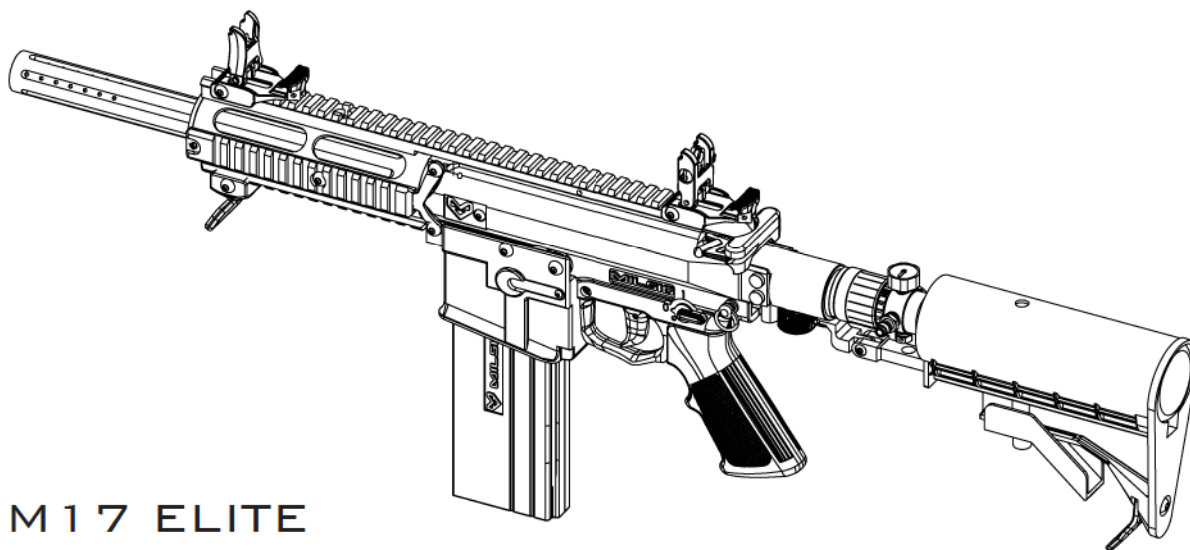

WARNING:

THIS IS NOT A TOY! MISUSE MAY CAUSE SERIOUS INJURY OR DEATH. EYE, FACE, AND EAR PROTECTION DESIGNED SPECIFICALLY FOR THE SPORT OF PAINTBALL MUST BE WORN BY THE USER AND ANY PERSON WITHIN RANGE. WE RECOMMEND AT LEAST 18 YEARS OLD TO PURCHASE. PERSONS UNDER 18 MUST HAVE ADULT SUPERVISION WHEN USING THIS PRODUCT. READ THE OWNER'S MANUAL BEFORE USING.

TECHNICAL MANUAL



M17 ELITE

Your M17 ELITE Includes:

- M17 ELITE Marker
- Polymer Flip Up Sights
- 1 18 Round FIRST STRIKE Magazine
- 1 20 Round Paintball Magazine
- 1 Tool Kit and Barrel Plug
- 1 False Magazine
- 1 Loader Feed Kit
- 1 Carrying Case

WARNINGS

- Do not load or fire this marker until you have completely read this manual and are familiar with its safety features, mechanical operation, and handling characteristics.
- Handle this and any marker as if it were loaded at all times.
- Keep your finger off of the trigger until ready to shoot.
- Do not look down the barrel of a paintball marker. Accidental discharge into the eyes may cause permanent injury or death.
- Keep the marker on safe until ready to shoot.
- Keep the barrel plug installed on marker when not shooting.
- Never point the marker at anything you do not intend to shoot.
- Never fire your marker at anything you do not intend to shoot because there may be balls or foreign debris lodged in the chamber, barrel, and / or marker valve.
- Do not shoot at fragile objects such as windows.
- Never fire your marker at personal property of others; the paintball can stain the paint of automobiles and houses.
- Always keep the muzzle pointed in a safe direction, even if you stumble or fall.
- Eye, face, and ear protection designed specifically to stop paintballs in the form of approved goggles, and full face mask should be worn by the user and any person within range.
- Never shoot at a person who is not protected by eye, face, and ear protection designed for paintball.
- Pressurize and load the marker only when the marker will be immediately used.
- Before storing or disassembling be sure to point your marker in a safe direction, fire several times to be sure there are no balls lodged in the chamber and / or barrel or air left in the marker. Install barrel plug.
- Store the marker unloaded and degassed in a secured place.
- Familiarize yourself with any warnings and instructions listed on the air supply cylinder.
- Contact the air supply cylinder manufacturer with any questions.
- Do not field strip or otherwise disassemble this marker while it is pressurized with air.
- Dress appropriately when playing the game of paintball. Avoid exposing any skin when playing the game of paintball.
- Even a light layer will absorb some of the impact and protect you from the paintballs.
- Keep exposed skin away from escaping gas when installing or removing air supply cylinder or if the marker or air supply is leaking. Compressed air, CO₂, and nitrogen gasses are very cold and can cause frostbite under certain conditions.
- Use only 68 caliber paintballs, never load or fire any foreign objects.
- Avoid alcoholic beverages before and during the use of this marker. Handling markers while under the influence of drugs or alcohol is a criminal disregard for public safety.
- Avoid shooting an opponent at pointblank, 2 Meters or less.
- Familiarize yourself with instructions listed on air supply cylinder or adaptor. Contact the air supply cylinder or adaptor manufacturer with any questions.
- Always measure your marker's velocity before playing paintball, and never shoot at velocities in excess of 300 feet per second.

WARRANTY

MILSIG warrants that this product is found free from defects in materials and workmanship for a period of 1 year from the original date of purchase by the original owner. Unauthorized modifications, alterations, neglect or abuse of this product voids this warranty. The warranty only covers the parts and labor required to repair the product to proper working order. MILSIG is dedicated to providing you with the best product and excellent support for your ultimate paintball experience.

EXCEPT WHEN MARKER IS IN USE, ALWAYS MAKE SURE THAT THE BARREL PLUG IS INSTALLED AND THE SELECTOR SWITCH IS IN SAFE MODE, WHICH DISABLES THE TRIGGER.

SAFETY

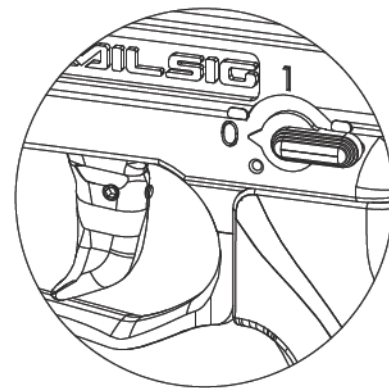
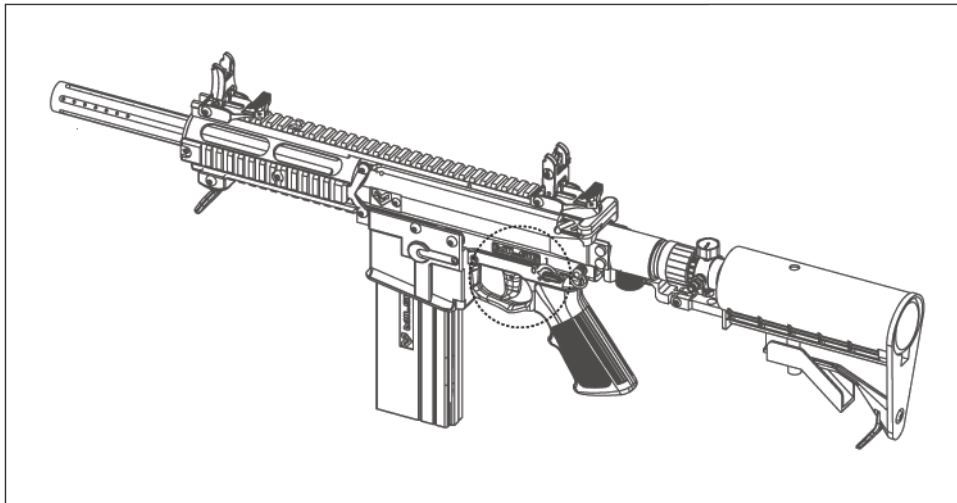

To turn ON the Safety (SAFE MODE):
To turn OFF the Safety (FIRE MODE):

Rotate Selector Switch counterclockwise until the arrow points to "0"
Rotate Selector Switch clockwise until the arrow points to "1" for semiauto;
to "∞" for full auto.

BARREL PLUG

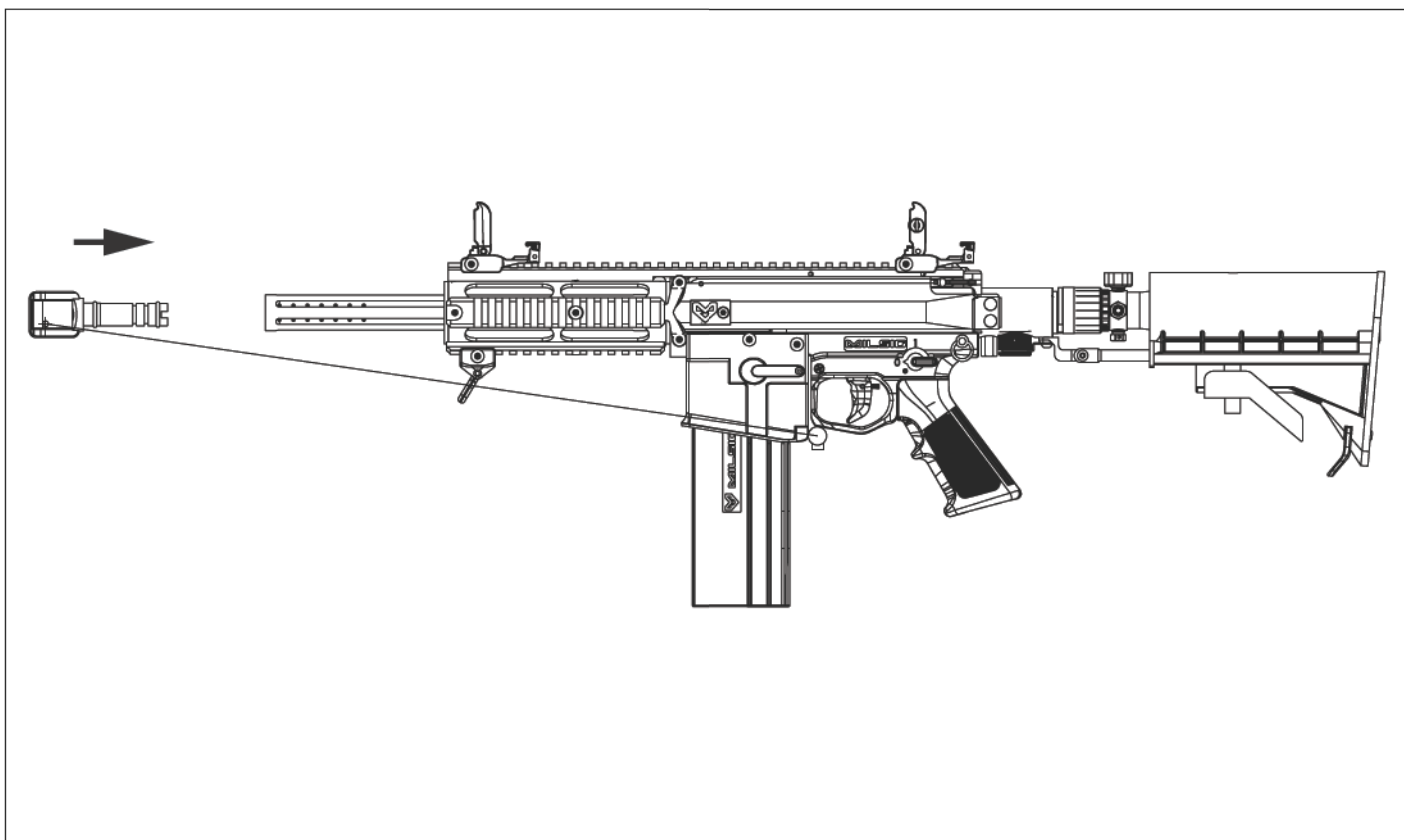

1. Insert plug into barrel and loop under the Magazine Well as shown.
2. Pinch cord length adjuster button and hold to back of Magazine Well as you pull cord through it until adjuster is snug against the back of the magazine well, then release.
3. Check to be sure there is enough cord elasticity to pull cord / adjuster off to remove barrel plug for firing.
4. After the cord length is adjusted, lock cord length by tying a knot in the cord against the back of the adjuster.

QUICK REFERENCE - USING YOUR MARKER

Before playing with your new M17 ELITE paintball marker there are a few important steps to take.

STEP 1. FEED MODE SELECTION

Your M17 ELITE marker is factory preset for magazine feed operation, if this is your desired feed mode, proceed to STEP 2.

LOADER FEED SET UP

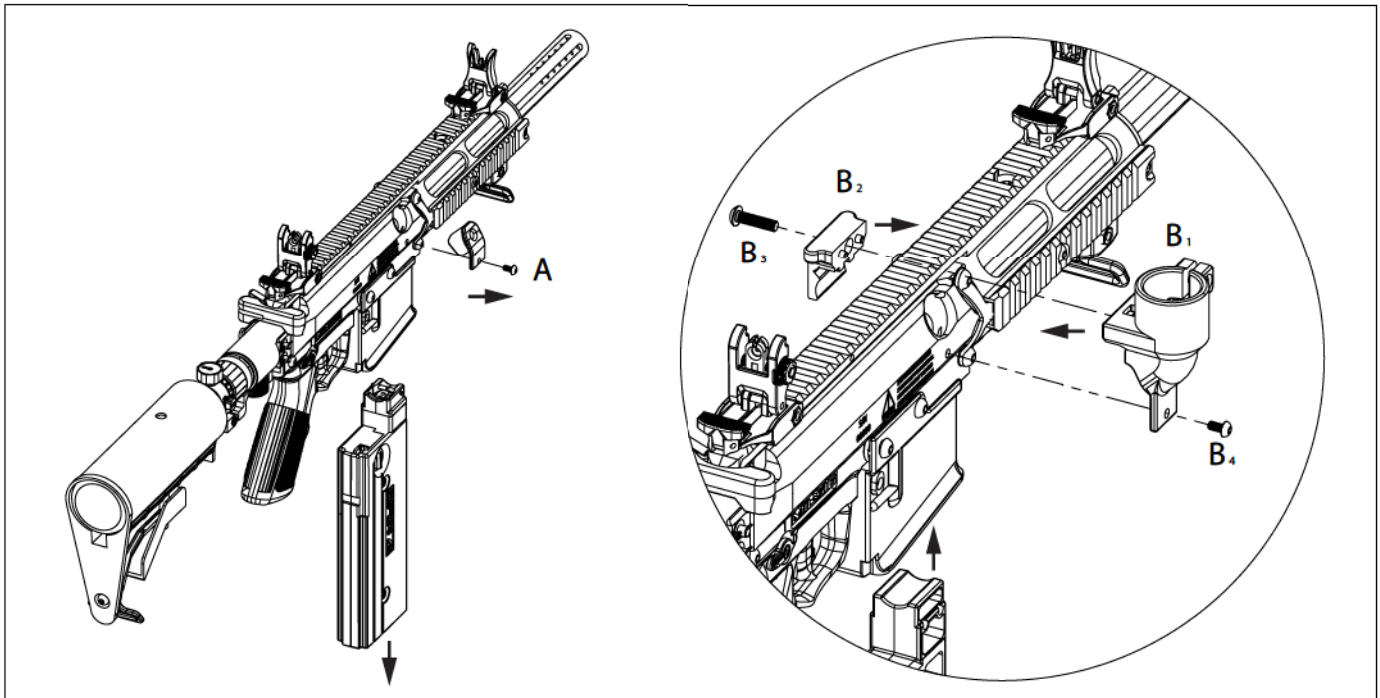

- A. Remove Side Feed Port Cover by removing bolt A with 2.5mm Allen Wrench; store Side Feed Port cover, bolts, and washers in a safe place for future use. Remove magazine.
- B. Place the main Loader Feed Adaptor body (B1) over the Side Feed Port located on the right side of the Receiver.
- C. Connect the Loader Feed Adaptor back plate (B2) to the main Loader Feed Adaptor Body (B3)
- D. Install screw (B4) with 2.0mm Allen Wrench, turn clockwise to tighten, your Loader Feed Adaptor should now be secured.
- E. Insert False Magazine and tap firmly into place.
- F. Install ELECTRONIC LOADER and secure to Loader Feed Adaptor.

WARNING: USE ONLY ELECTRONIC LOADERS, MARKER WILL NOT FUNCTION WITH GRAVITY FED LOADERS!

STEP 2. FILL MAGAZINE

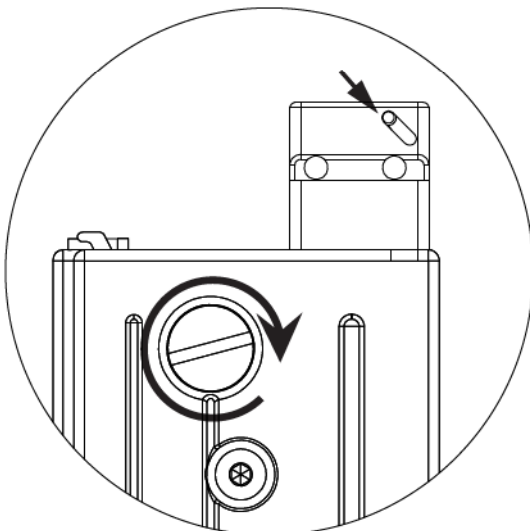

- A. Turn Magazine winder clockwise until tight. Do NOT overtighten.
- B. Hold down Ball Detent Bar and feed paintballs in one by one.
- C. Fill to capacity. Do NOT partially fill Magazine.

NOTE:

The ELITE comes with a 18rounds paintball / FIRST STRIKE projectile magazine and a 20rounds paintball only magazine.

For use with more brittle paintballs, we recommend the use of the 20rounds paintball magazine only. (Purchased Separately)

The stronger spring tension of the 18rounds magazine may lead to marker malfunctions.

For easier magazine winding, use the tip of the barrel plug as a magazine winding tool.

STEP 3A. ATTACHING AIR SOURCE

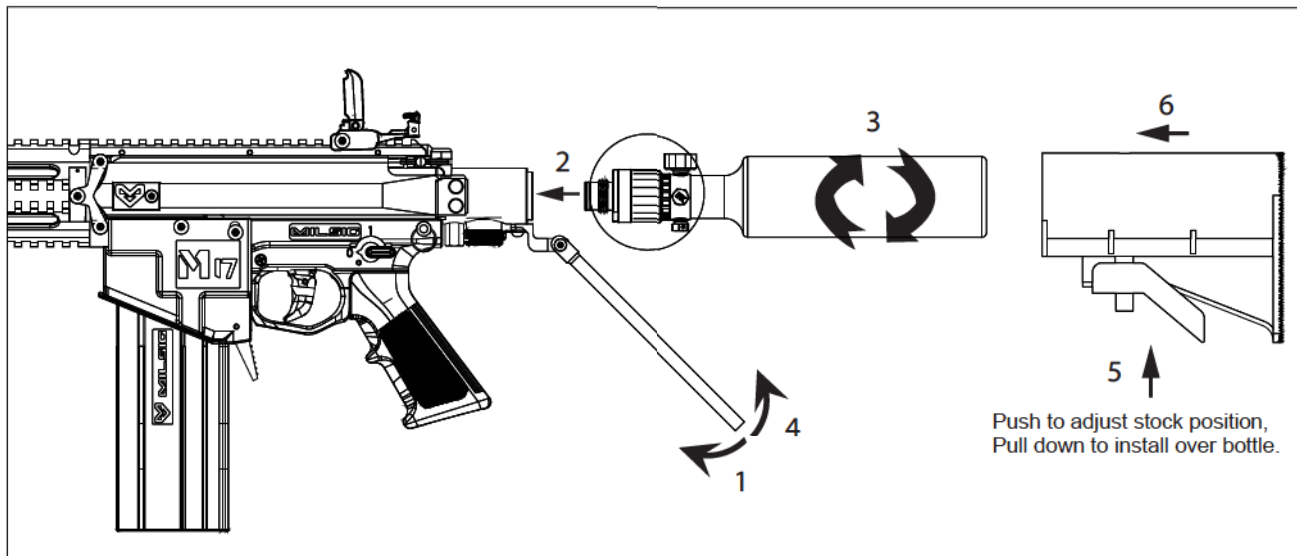

Your M17 ELITE marker is factory preset to accept air via a 13CI HPA (High Pressure Air) Bottle. We recommend using the MILSIG Factory 13CI HPA bottle with MILSIG NODE™ Air Regulator. (Purchased Separately) The MILSIG NODE™ Air Regulator has features that make it the best functioning Air Regulator for your M17 paintball marker, these include: *Pin-Valve-Less Design, Built in On / Off, Adjustable Bonnet Positions, and Adjustable output pressure (Vendor Serviced)*

HPA BOTTLE INSTALLATION

WARNING:

USE ONLY HIGH PRESSURE AIR (HPA). DO NOT USE CO2!

- Ensure breech is empty and barrel plug is installed (see P.3)
- Ensure that the HPA regulator output pressure is set between 600 and 850psi, and has adjustable bonnet positions.
- Lower Stock Guide Rail and insert bottle into back of the marker, turn clockwise to tighten.
- With the Air Bottle In place, check the position of the fill nipple and pressure gauge. If either the fill nipple or pressure gauge obstructs the guide rail, follow the Regulator Manufacturer's guide to reposition the Air Regulator.
- Install stock over the bottle and adjust to the desired position, fill Air Bottle to appropriate air pressure.

MILSIG NODE™ Regulator Bonnet Position Adjustment

- ENSURE that the Air Bottle is DE-PRESSURIZED. Adjusting the Bonnet position with a pressurized Air Bottle can cause personal injury.
- Locate 3 Allen Set Screws inside Bonnet Adjustor Ring, illustrated as "B".
- Loosen all 3 Allen Set Screws with 2.0mm Allen Wrench, do not remove completely.
- Rotate Air Bottle or Bonnet to the desired position, retighten all 3 Allen Set screws.

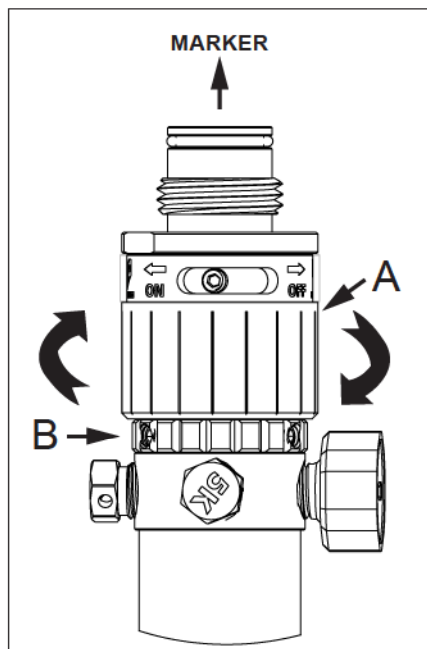

MILSIG NODE™ Regulator Built-In On / Off

Unlike conventional Air Regulators, the MILSIG NODE™ Air Regulator does not use a pin valve to shut off airflow. Instead, it uses a built-in air shut off that is controlled by a rotating On / Off ring. By eliminating the use of a pin-valve, maximum air flow is achieved. The On / Off also serves as a marker degasser. When the rotator ring is turned to the OFF position, the entire marker is degassed. This allows the Air Bottle to be removed with the marker and ASA in a pressure-less state, which dramatically reduces wear and tear on the marker ASA and the regulator bonnet.

To turn Air On, rotate On / Off rotator ring, illustrated as "A" from right to left;
To turn Air Off, rotate from left to right.

STEP 3B. ATTACHING BARREL AND ACCESSORIES

Insert barrel into marker, turn clockwise to tighten. Your M17 marker comes with detachable sights, which are not factory installed. Simply place sights at the desired rail position and tighten downthumbscrews. Any other accessory should be attached to the marker at this time.

STEP 4. CHECKING THE VELOCITY

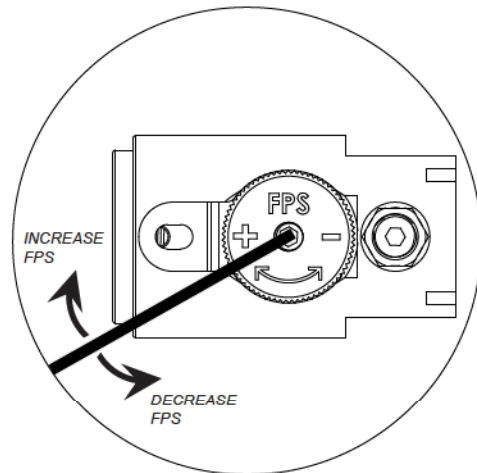
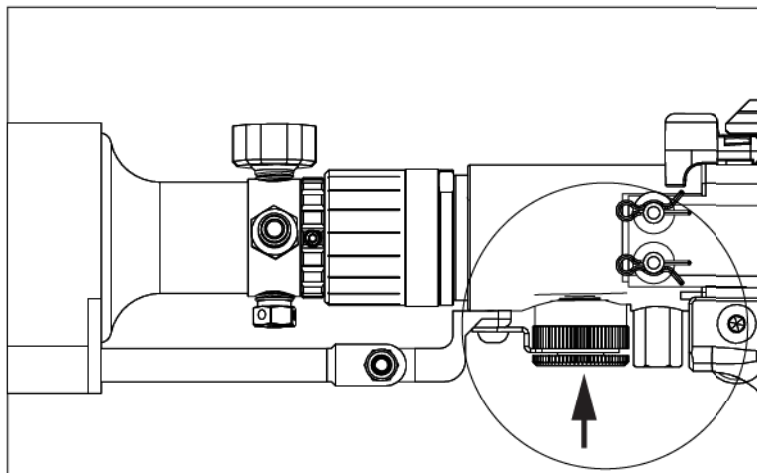

The Velocity Adjustment Set Screw is located on the underside of the HEAT CORE Regulator

Adjust output pressure with 3mm Allen Wrench via Velocity Adjustment Set Screw

- A. Make sure you and everybody around you is wearing Paintball Approved Masks.
- B. Make sure the Marker is on safe by checking the Selector switch.
- C. Fill Pre-Installed Air Bottle with HPA (High Pressure Air) Only.
- D. Insert pre-filled Magazine, release safety, and fire several shots over chronograph to check initial muzzle velocity; the factory setting is approximately 275fps, but a + / - 15 fps variance can occur due to different playing environments.
- E. Increase velocity by turning velocity adjustment set screw clockwise, or decrease velocity by turning Adjustment Screw counterclockwise. Fire several shots to retest velocity once further adjustments are made.
- F.

NOTE: Allow Air Pressure to stabilize inside the marker after every velocity adjustment by firing multiple shots over the Chronograph. Velocity changes may require several shots before taking effect. Marker may discharge one single shot when it is first aired up. This is caused by a bolt left in its forward position from previous use. The bolt will reset itself and is not a sign of a malfunction.

WARNING: DO NOT EXCEED 300 FPS, DOING SO IS UNSAFE FOR YOURSELF AND OTHER PLAYERS AROUND YOU AND CAN CAUSE DAMAGE TO YOU MARKER.

CHANGING MAGAZINE

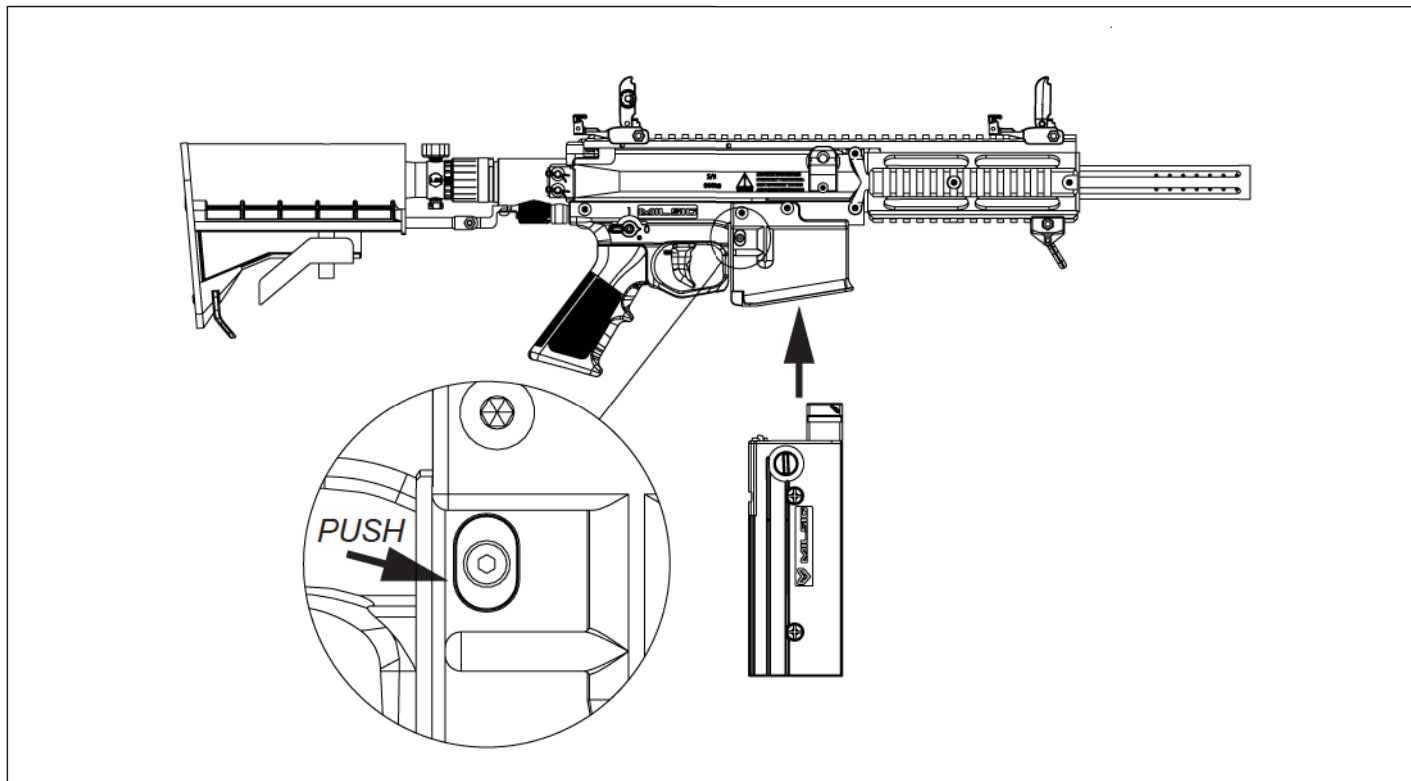

RELEASE MAGAZINE

With the barrel pointing AWAY from you, depress the Magazine Release Button.

LOAD MAGAZINE

Orient Magazine as shown and insert FIRMLY into Magazine Well until it clicks and locks into place.

TRIGGER ADJUSTMENT

Your M17 marker is designed to function primarily as a Semiautomatic fire, Mechanical Magazine Fed Marker. It is tuned for maximum efficiency and accuracy in this firing mode. It also has a Full Automatic fire capability that can be used periodically to enhance your experience. While the default Semiautomatic fire mode will function within the normal working perimeters of the marker, the Full Automatic firing mode has more specific perimeters that must be met for smooth operation.

- A. Muzzle Velocity must be set between 240 fps and 290fps
- B. Air tank input pressure must be between 600 and 850psi (Do NOT exceed 850PSII)
- C. Trigger must be set properly

The Trigger may need periodic adjustment for the Full Automatic fire mode to function smoothly. Full Automatic Fire can only be achieved when the Trigger Adjuster (illustrated as "B") is set to its "sweetspot". The sweetspot location changes with the system operating pressure or muzzle velocity.

For example, if the marker is set up for use at an outdoor field at 280fps, and then lowered to 240fps for indoor use, the Full Auto mode may not function smoothly. A small adjustment may be necessary once the marker is set at the lowered velocity, and again when the velocity is raised back up for outdoor use. Note that your M17 trigger is factory set at 275fps.

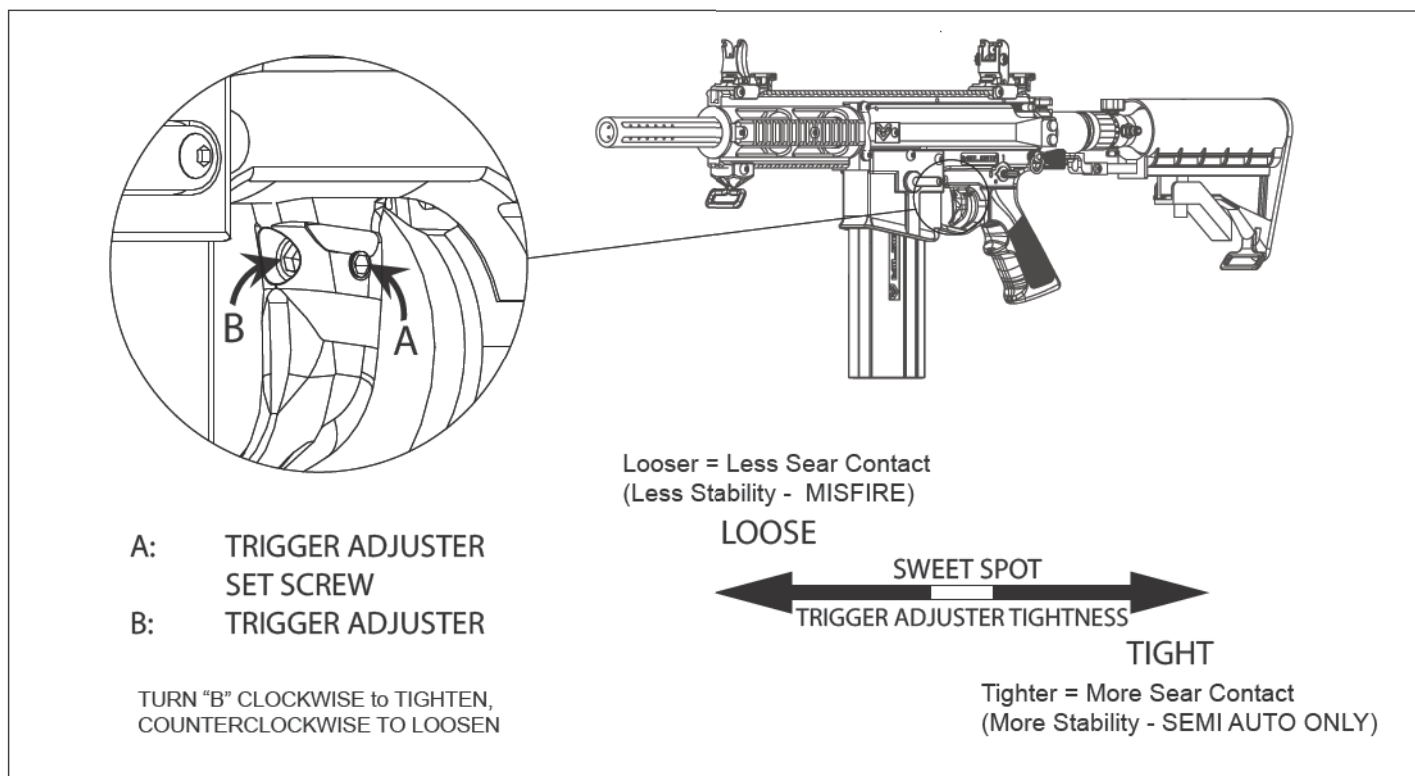

The Trigger Adjustment process should be performed immediately after the marker has been chronographed, and the desired muzzle velocity is set.

- A. Remove magazine or hopper and clear the marker of paintballs. (The entire Trigger Adjustment process is performed by dry firing only.)
- B. Ensure that there is sufficient Air Pressure inside the Air Bottle.
- C. With Selector Switch set to Full Auto Fire mode, pull the trigger and perform a 2-3 second burst.
- D. Note how the marker behaves during the burst test, if the Full Auto Burst is inconsistent, or that the marker misfires, the Trigger Adjuster will need to be tightened. If the marker does not sustain a steady burst, or that it only shoots Semiauto, the Trigger Adjuster will need to be loosened. If the marker does a steady burst, no adjustment is needed.
- E. To adjust, loosen the Trigger Adjuster Set Screw (labeled as "A" on the diagram above) by turning it counterclockwise with a 1.5mm Allen Wrench; do not completely remove.
- F. Insert a 2.5mm Allen Wrench into the Trigger Adjuster (labeled as "B" on the diagram above) and turn clockwise to tighten, and counterclockwise to loosen. Turn Trigger Adjuster only 1/8th of a turn at a time, and fire a test burst after every minute adjustment. Once you are able to achieve a smooth burst, the Trigger is set.
- G. Tighten Trigger Adjuster Set Screw "A" by turning it clockwise. Turn it until finger snug, do not overtighten.

BOLT RESET HANDLE (BRH)

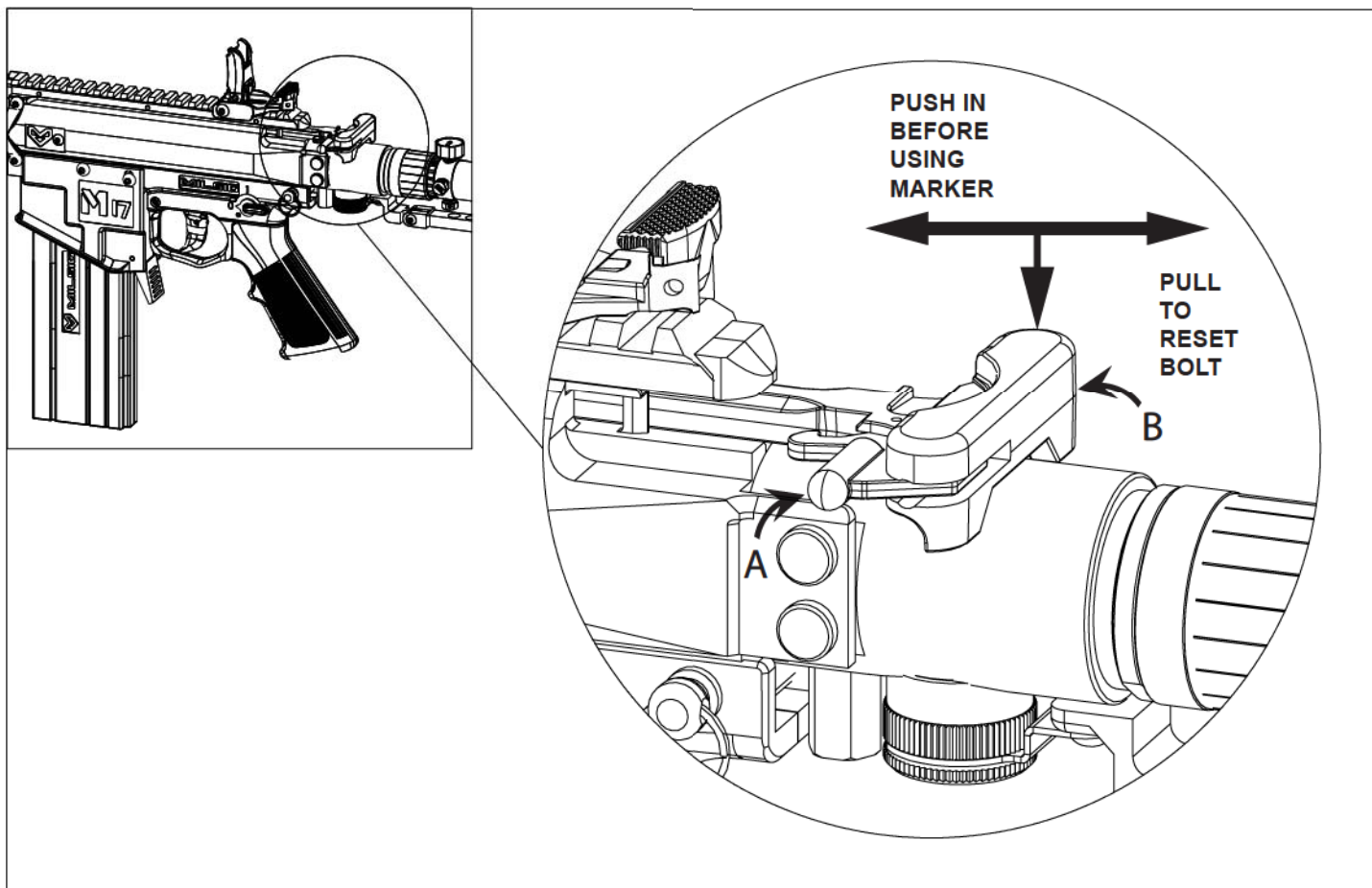

The BOLT RESET HANDLE (BRH) is located on the top of the receiver, directly under the Top Rail. Its shape and location on the receiver is the same as that of a real Armalite Rifle. However, it DOES NOT FUNCTION AS A COCKING HANDLE, and there is NO NEED to “rack” it to put the marker into battery before use. Your M17 marker utilizes the MILSIG HEAT CORE™ operating system, which is a “blowforward” operating system. The bolt will automatically go into battery when the marker is aired up.

There are two common scenarios which will require the use of the Bolt Reset Handle, they are as follow:

- A. A stuck bolt caused by a paintball or FIRST STRIKE round break inside the breech of the marker
- B. A spluttering bolt caused by insufficient air pressure (low air or velocity set too low)

To Reset The Firing Bolt

- A. Put the marker in SAFE MODE
- B. With the marker pointing away from you, grab the Bolt Reset Handle Retention Hinge (Located on the left hand side of the Bolt Reset Handle, illustrated as “A”) and the Bolt Reset Handle (illustrated as “B”) simultaneously and pull the BRH towards you until its furthest back position. Note that the travel distance of the handle is very short, at approximately 5cm or 2”. Do NOT release the BRH at this point.
- C. Manually push the BRH back inside the marker to its most forward position.
- D. Take appropriate measures to further troubleshoot marker if necessary.

WARNING!

DO NOT operate your M17 marker before the Bolt Rest Handle is pushed into its most forward position, firing the marker with the BRH pulled back can cause the marker to malfunction, and potentially damage the BRH or the marker itself. The firing bolt is directly linked to the BRH, and it moves with tremendous force during the firing cycle; therefore, the BRH must be in its most forward position to ensure the firing bolt’s travel path is not obstructed.

The BRH is spring loaded and will pull itself forward under spring tension. However, do NOT release the BRH when it is at its most back position, thus allowing it to return to the forward position solely under spring tension. Doing so will cause the BRH to slam forward into the marker body with more force than is necessary, thus causing unnecessary wear and tear to the BRH and the marker body itself. Please note that any damage to your M17 marker caused by misuse of the BRH is NOT covered by the limited warranty.

Selector Switch / Safety:

Your M17 selector switch is non ambidextrous, however, you can swap its position from the left hand side to the right hand side. Simply remove the selector switch by removing the selector switch locking screw with a 3.0mm Allen Wrench. Re-install the selector switch on the opposite side of the grip frame and re-install locking screw.

Standardized AR Pistol Grip:

Your M17 Pistol Grip is standard AR sized. The grip frame will accept most aftermarket pistol grips designed for the ArmaLite Rifle. Do note that some aftermarket grips may not have contours that matches perfectly with your M17 grip frame. To change grip, simply remove grip locking screw with 3.0mm Allen Wrench.

Note: Some aftermarket grips may include its own grip screw, use ONLY the factory M17 screw to attach all grips.

MAINTENANCE

WARNING:

Before conducting any marker maintenance, remove magazine / loader, point marker in a safe direction, and discharge until degassed.

These Additional Tools may be required for maintenance or marker take-down:

Non-Corrosive Lubricant
(for best results use MILSIG SOS II Lube)
Small Phillips Head Screwdriver
Small Flat Head Screwdriver
Small Pick for removing O-Rings
Tech Mat

Maintenance Intervals:

We recommend a thorough check of the marker before every use, to ensure that all parts are securely installed, and o-rings are properly lubricated for best performance.

Pre-Use Check:

1. Remove HEAT CORE from marker by removing RECEIVER / HC PINS. (refer to P. 12 "RECEIVER 2")
2. Remove Bolt from Air Chamber, check Bolt and make sure that all parts are securely fastened.
3. Check Air Chamber and make sure that all parts are securely fastened.
4. Check AC Bumper O-Ring, replace if there are any signs of wear. (refer to P. 13 "HEAT CORE")
5. Place one dab of lubricant on the surface of the AIR CHAMBER BODY (refer to P. 13 "HEAT CORE")
6. Remove any excess lubricant with a soft cloth or paper towels. DO NOT over lubricate, over lubrication can lead to marker malfunctions.
7. Place one dab of lubricant on AC Main O-Ring (refer to P. 13 "HEAT CORE").
8. Place Bolt over Air Chamber, install Bolt Spring, and re-install HEAT CORE to receiver.
9. Re-Attach HEAT CORE LOCKING PINS, your marker is now ready for use.
10. Drop 1 small drop of oil into the small air hole found in your ASA. (refer to P. 13 "HEAT CORE")
11. Check Air Bottle O-Ring, replace if there are any signs of wear.
12. Proceed to marker set up (P. 4) when ready to use.

NOTE:

Pull the trigger once when re-installing the HEAT CORE back into the Receiver Body.

REPLACING WEAR AND TEAR ITEMS:

There are TWO major wear and tear items that may need periodic replacement as they wear out. They are the "Bolt to AC Bumper" and "AC Main O-Ring". (Parts 13 & 15 as labeled on P.13 "HEAT CORE") A spare unit of each is included with your marker.

TO REPLACE:

- A. Bolt to AC Bumper - Remove HEAT Core from Marker, separate Bolt Assembly from Air Chamber, slide old Bumper off and discard. Install new Bumper, ensure that it seats properly in the cut out slot of the Air Chamber, reassemble HEAT Core.
- B. AC Main O-Ring (Orange O-Ring) - Remove HEAT Core from Marker, separate Bolt Assembly from Air Chamber, using a small pick, carefully pry old O-Ring out from the tip of the Air Chamber and discard. Install new o-ring with a non pointy object, slowly work the sides of the o-ring into the cut out slot of the Air Chamber. Put 1 drop of oil on the o-ring, reassemble HEAT Core.

WARNING:

DO NOT USE MARKER IF ANY PART OF THE BOLT OR THE AIR CHAMBER IS LOOSE. DO NOT USE MARKER WITHOUT AN AIR CHAMBER (AC) BOLT BUMPER. DO NOT USE MARKER WITH A WORN OUT AIR CHAMBER (AC) BOLT BUMPER.

STORAGE:

1. Remove magazine or loader and remove remaining paintballs. AVOID reusing old or deformed paintballs.
2. Discharge remaining gas in the Marker and remove the Air Source.
3. Put Marker on SAFE and install Barrel Sleeve.
4. Place Marker in a suitable storage device.

MAGAZINE MAINTENANCE:

1. Remove all paintballs and / or FIRST STRIKE projectiles from your magazine.
2. Remove Magazine Body Screws with small Phillips Screw Driver.
3. Separate the Magazine Body, remove Magazine Feed Assembly and Magazine Winder Assembly.
4. Wipe off any left over paint residue from disassembled magazine parts. If desired, all parts can be washed with mild soap and warm water. Make sure to completely dry all surfaces with paper towels or a hair dryer when finished.
5. Apply light coat of oil to the feed channel of the marker body, apply 1-2 drops of oil on the winder mechanism.
6. Re-Assemble magazine when finished, do NOT overtighten Magazine Body Screws.

BALL DETENT:

The Ball Detent is located under the MILSIG Name Plate, access to the Ball Detent is gained by removing 2 Name Plate Bolts. (see P. 13 "RECEIVER 3")

ADDITIONAL TECHNICAL INFORMATION:

For additional technical information such as How to Videos, FAQs, Performance / Upgrade Tips, and the latest product information, please refer to our website at www.milsig.com and follow us via the following social media platforms.



facebook.com/milsigpb



youtube.com/milsig



twitter.com/milsigpb

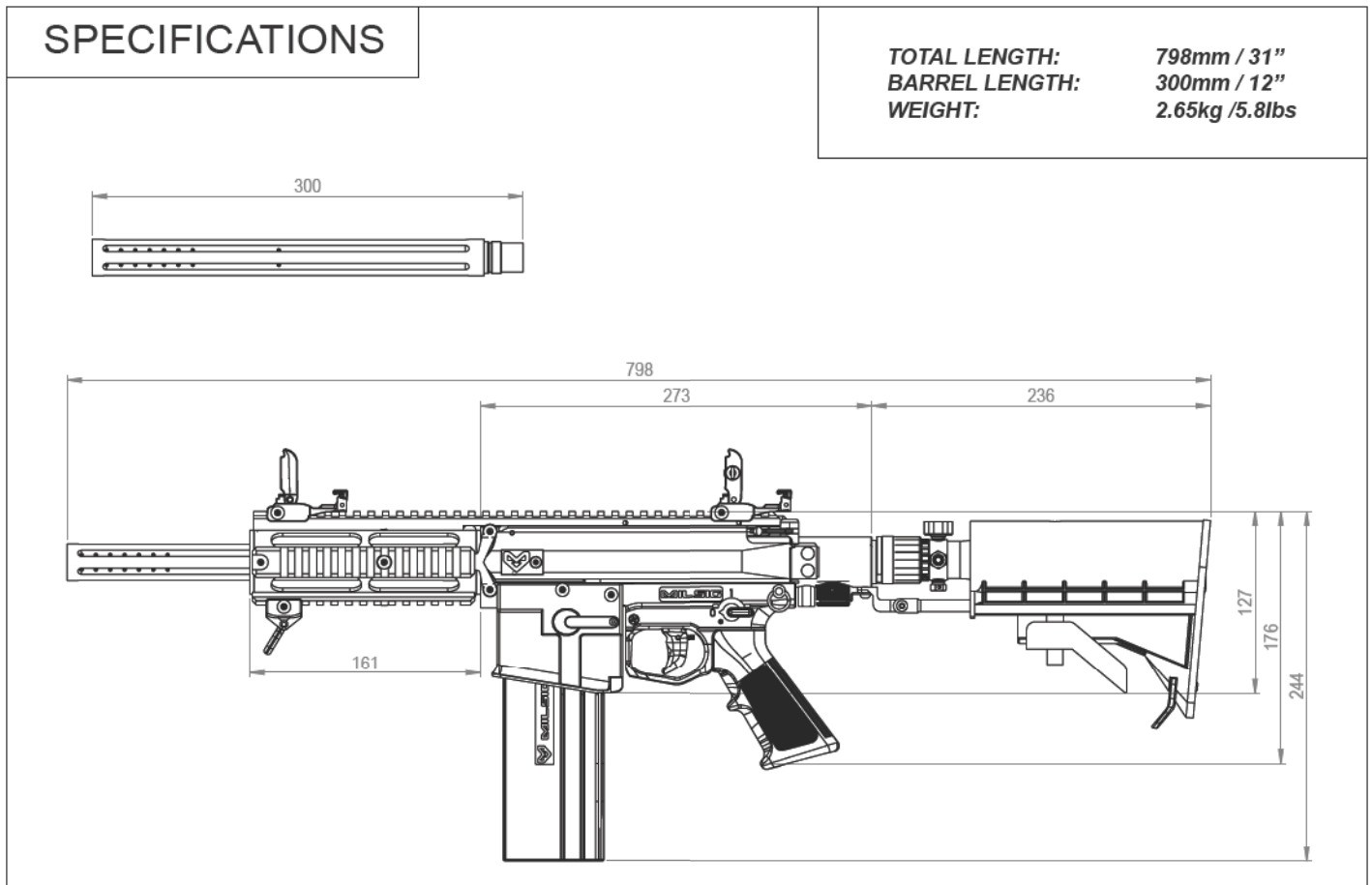

TROUBLESHOOTING

SYMPTOM: (S) / REMEDY: (R) / CAUSE (C)

1. S: Marker won't air up / Bolt Spultters when aired up.
R: A: Check marker input pressure (velocity). B: Check Air Source Air Pressure. C: Check Main Bolt O-Ring
C: The bolt cannot recock itself without sufficient air pressure, or a bad o-ring leading to bad air seal.
2. S: Marker fires a single shot on its own when it's first aired up.
R: None
C: This occurs when the bolt is left in an uncocked position after its last use. The bolt will complete a single firing cycle on its own before it recocks, this is a normal occurrence and is not a malfunction.
3. S: Bolt Spultters during use.
R: A: Pull Bolt Reset Handle (See "B.R.H." P. 8) and reset bolt. B: Check Air Source Air Pressure, refill Air Bottle if pressure is low
C: Unload magazine and check the breech for obstruction. Remove obstruction and clean breech / barrel if necessary.
C: The Air Pressure from the air source has dipped below the Minimum Operating Pressure needed for the marker's bolt to cycle. A broken paintball or FIRST STRIKE round is obstructing the bolt, disabling it from cycling.
4. S: Marker misfires / fires more than one shot with each trigger pull in Semiautomatic mode.
R: A: Remove HEAT CORE, check main bolt o-ring, replace if worn. B: Remove grip frame, check Sear Spring, and Sear. Replace one or both if necessary.
C: A worn o-ring may cause the bolt to not seal properly, thus causing it to not cycle properly. A weakened or worn sear spring or worn sear may cause the sear to not catch the bolt as it cycles, allowing the bolt to fire again before it is locked back.
5. S: Marker fires Single Shots only in Full Automatic Mode.
R: A: Check marker's muzzle velocity to make sure that it is within the operating range of the Full Automatic function, adjust velocity if necessary. B: Follow "Trigger Adjustment" instructions on (P. 7) to make sure the trigger is properly adjusted.
C: Velocity is set outside of the operating range of the Full Automatic function, or an improperly adjusted trigger.
6. S: Marker misfires / doesn't cycle properly in Full Automatic Mode.
R: A: Check marker's muzzle velocity to make sure that it is within the operating range of the Full Automatic function, adjust velocity if necessary. B: Follow "Trigger Adjustment" instructions on (P. 7) to make sure the trigger is properly adjusted.
C: Velocity is set outside of the operating range of the Full Automatic function, or an improperly adjusted trigger.
7. S: Small Air Leak (hiss) from inside of the marker.
R: A: Remove HEAT CORE From Marker. B: Check Bolt and Air Chamber for structure integrity, if any part of the Bolt and / or Air Chamber is loose, rebuild as necessary. C: Check all HEAT CORE O-Rings, replace if necessary.
C: Loose Bolt or Air Chamber causing the HEAT CORE to not seal properly. Worn O-Ring(s) causing a bad seal.
8. S: Small Air Leak (hiss) from outside of the marker.
R: A: Listen for the leak and identify source. If leak is coming from the back of the marker, it may be the air source. If leak is coming from the underside of the marker, it may be the air source or the PRV (Pressure Relief Valve). B: If leak is from air source, replace o-ring. If leak is from PRV, check and adjust marker velocity as needed. If PRV continues to leak air when marker is at a safe operating pressure, it may need to be rebuilt or replaced.
C: Bad o-ring on Air Source (Air Bottle) causing a leak around the ASA. Muzzle velocity of the marker set too high and PRV is activated. A worn or stuck PRV internal air plug causing the PRV to bleed air inadvertently.
9. S: Air Bottle cannot be screwed into the marker all the way / Fill Nipple / Air Bottle Pressure Gauge obstructs the stock rail.
R: A: Use only an Air Bottle with an adjustable position bonnet. B: Follow the Air Bottle (Regulator) Manufacturer's instruction on Bonnet position Adjustment.
C: This is self explanatory.
10. S: Body Screws too tight to remove / Sparks occur when twisting off Body Screws.
R: A: Use professional tools or purchase the "MILSIG PROFESSIONAL TOOL SET" for advanced marker servicing.
C: The marker's body screws are all tightened with precision pneumatic tools at a preset tension. The tension is set high to ensure that the receiver does not come loose under the tremendous stress of the HEAT CORE's cycling. The included mini tool set is designed for only basic maintenance and may not be sufficient to completely take down the marker. Sparks may occur when loosening the body screws due to metal on metal friction and is no cause for alarm.
11. S: Can't insert HEAT CORE back into marker once taken out.
R: A: Pull B.R.H. out, and place hammer guide pin under B.R.H. B: Pull trigger to prevent blockage of the HEAT CORE.
C: This is self explanatory.
12. S: Trouble removing Barrel from marker / Barrel Back gets stuck to the marker but barrel threads out.
R: A: Always use Barrel O-Ring on all threaded points of barrels and / or barrel backs.
C: Overtightening of barrel into barrel block, worn or missing barrel o-ring causing too much friction between barrel and mounting surface.

RECEIVER 1

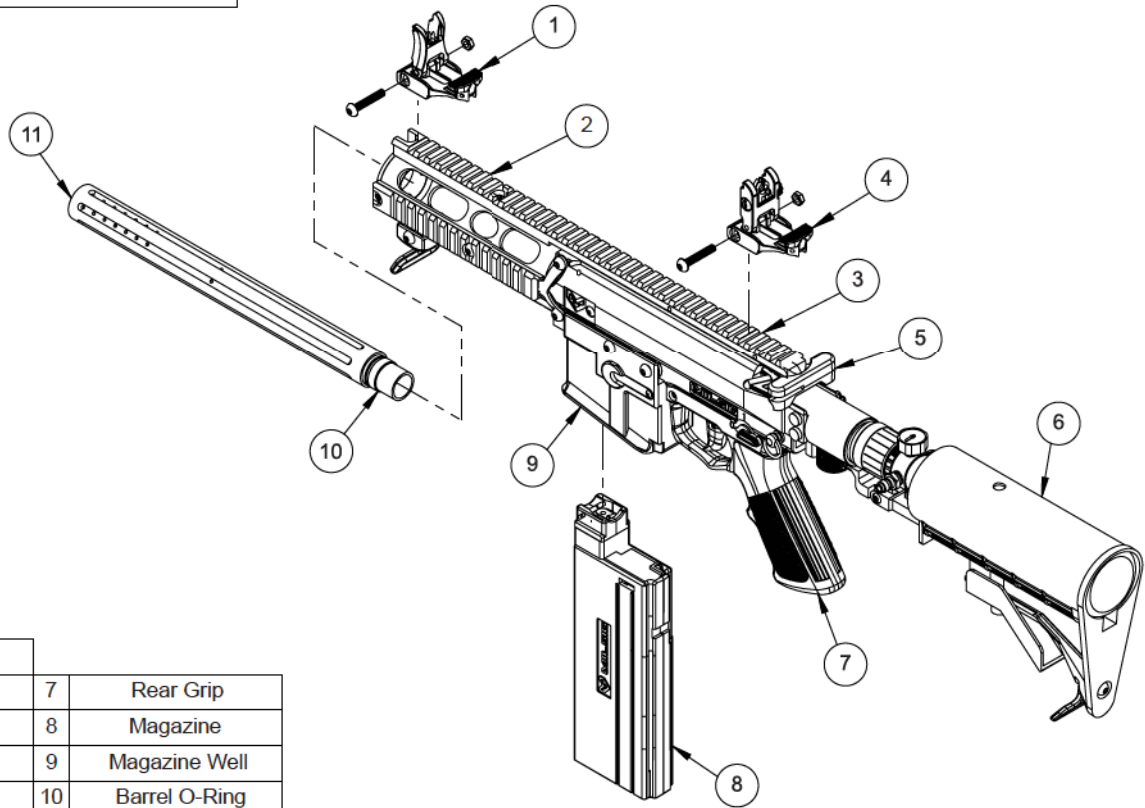

1	Front Sight	7	Rear Grip
2	Shroud	8	Magazine
3	Receiver	9	Magazine Well
4	Rear Sight	10	Barrel O-Ring
5	B.R.H.	11	Barrel
6	Buttstock		

RECEIVER 2

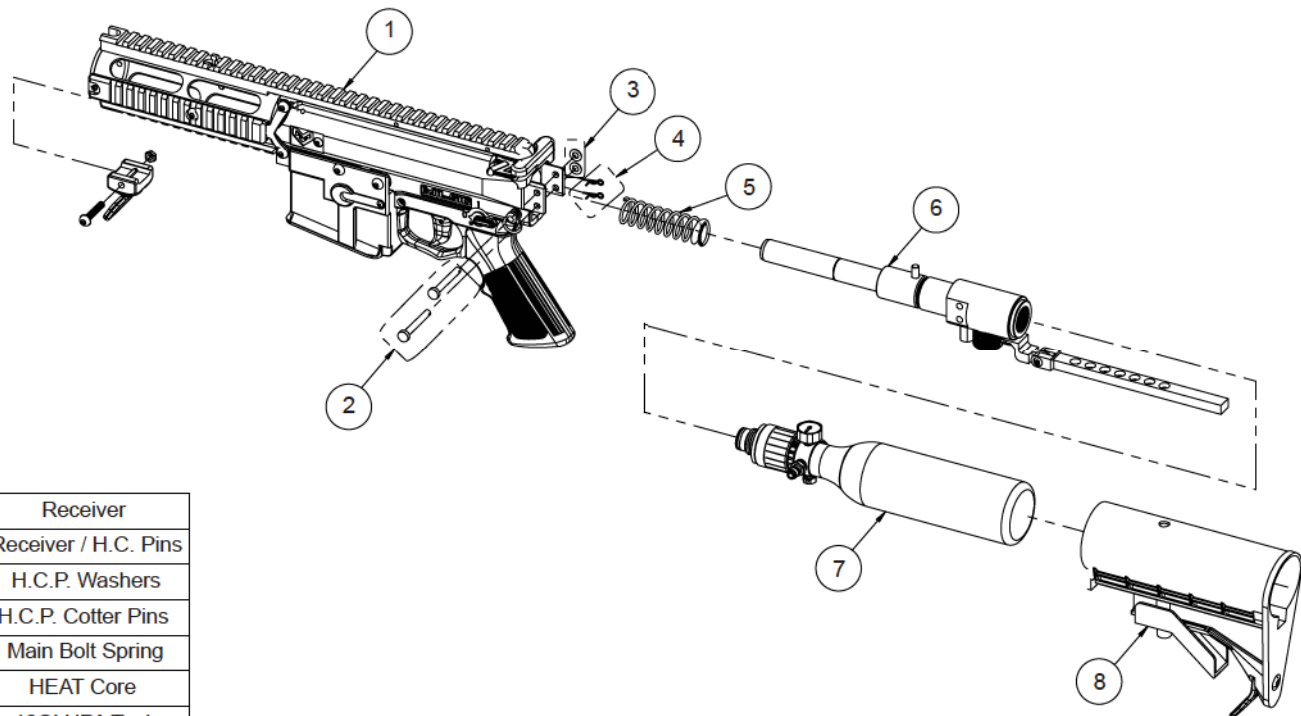

1	Receiver
2	Receiver / H.C. Pins
3	H.C.P. Washers
4	H.C.P. Cotter Pins
5	Main Bolt Spring
6	HEAT Core
7	13CI HPA Tank
8	Buttstock

RECEIVER 3

1A	Barrel Block
1B	Barrel Block Pins (2pcs)
1C	Bolt Guide
2A	Receiver Body
2B	Top Rail
2C	Receiver Body Pins (3pcs)
2D	Receiver Screws A (1pcs)
2E	Receiver Screws B (2pcs)
3A	R. Metal Bracket
3B	R.M.B. Screws (2pcs)(M5 x 10)
4A	Side Breech Cover
4B	S.B.C. Screws (1pcs)(M4 x 10)
5A	Hopper Feed Neck
5B	Hopper Feed Neck Screw (1pcs) (M5 x 20)
5C	Hopper Locking Screw (M4 x 14)
5D	Hopper Locking Nut (M4)
5E	Hopper Feed Neck Nut (M5)
6	Bolt Reset Handle

7A	Grip
7B	Grip Pin
7C	Grip Pin Screw (M5 x 10)
8A	Magazine Well
8B	M.W. Pin (2pcs)
8C	M.W. Screws (4pcs)(M5 x 10)
9A	Name Plate
9B	N.P. Screw (M4 x 8)

10	Ball Detent
11A	L. Metal Bracket
11B	L.M.B. Screws (2pcs)(M5 x 10)

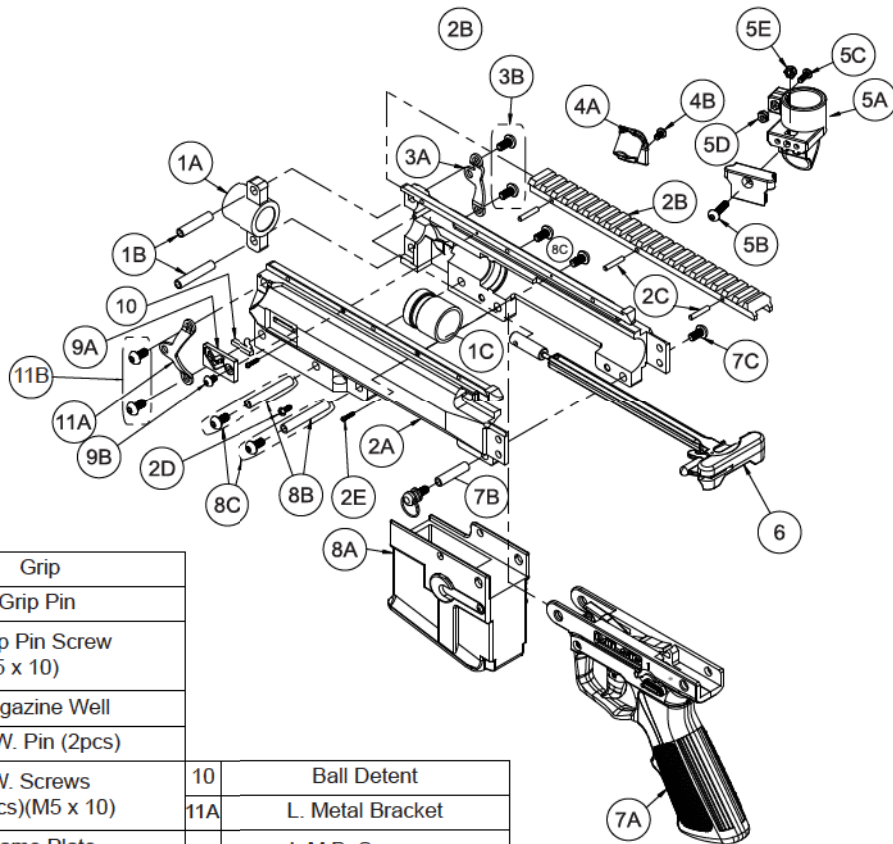

HEATCORE

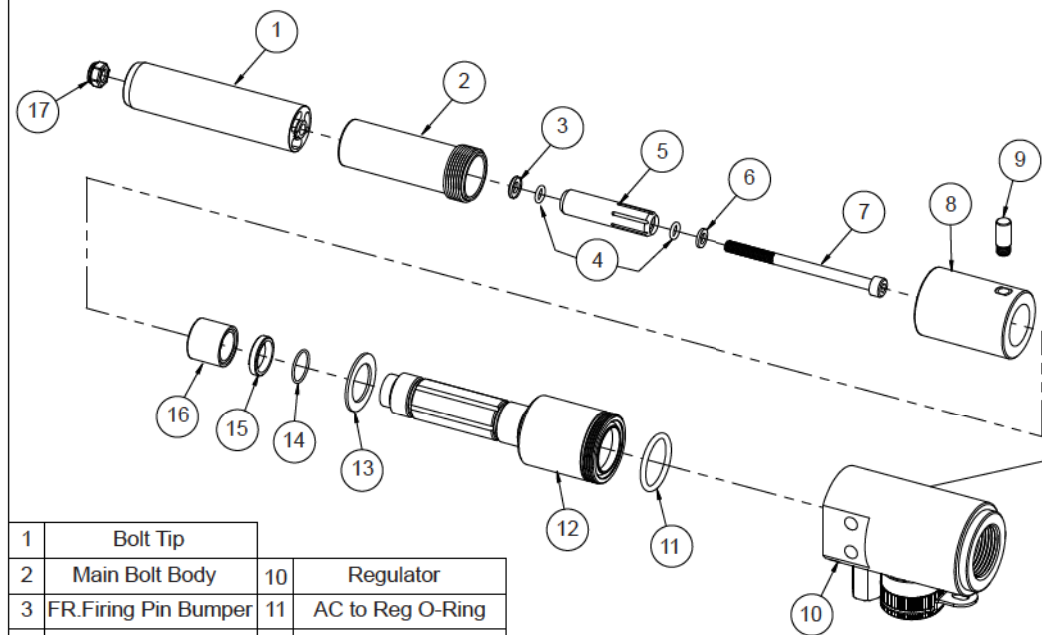

1	Bolt Tip	10	Regulator
2	Main Bolt Body	11	AC to Reg O-Ring
3	FR.Firing Pin Bumper	12	Air Chamber
4	Firing Pin O-Rings	13	Bolt to AC Bumper
5	Firing Pin	14	AC Cap O-Ring
6	RR.Firing Pin Bumper	15	AC Main O-Ring
7	Bolt Stem Screw	16	AC Cap
8	Bolt Stem	17	Bolt Stem Nut

1	Regulator Body	6	Reg. Cover
2	Reg. O-Ring	7	Velo. Adj. Screw
3	Reg. Piston Head	8	P. R. V.
4	Reg. Shim Stack	9	P. R. V. O-Ring
5	Reg. Piston Base		

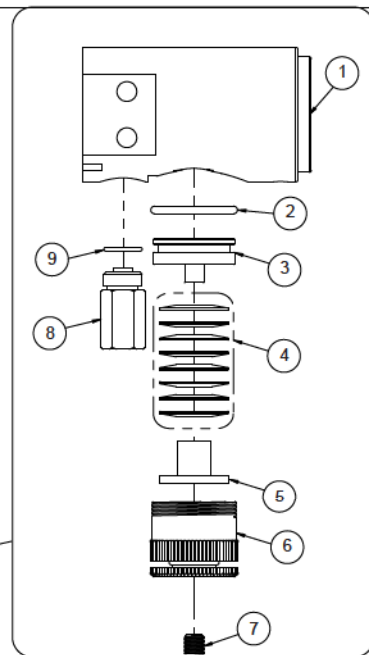

EXCLUSIVE DISTRIBUTORS / SERVICE CENTERS

ASIA / H.O.



Contact Person: Nelson Lau
Business Name: Han-Ma Enterprises Company Limited
Business Address: 1F, Sec 4, Chung Ching North Rd.
Shihlin Dist. Taipei City 111, Taiwan
Business Phone: +886-2-2811-0539
Email: info@milsig.com
Web: www.milsig.com
Facebook: facebook/MILSIGPB
facebook/groups/milsigowners

CANADA



Contact Person: Evan Henshaw
Business Name: WMI Sports Ltd.
Business Address: 171 A Rink St. Suite 245
Peterborough ON K9J 2J6 Canada
Business Phone: 1-705-313-1340
Email: info@milsigdirect.ca
Web: www.milsigdirect.ca
Facebook: facebook/MilsigDirectCanada

EUROPE



Contact Person: Tom Novotny
Business Name: TACRON S.R.O.
Business Address: Husovo nam. 51/16, 39701, Pisek
Czech Republic
Business Phone: +420-702524600
Email: info@milsigdirect.eu
Web: www.milsigdirect.eu
Facebook: facebook/MilsigDirectEurope

USA & SOUTH AMERICA



Contact Person: Doug Brown / Aaron Yendall
Business Name: Milsig Direct LLC.
Business Address: PO BOX 177,
LANDRUM SC 29356 USA
Business Phone: 1-864-457-7384
Email: sales@milsigdirect.com
Web: www.milsigdirect.com
Facebook: facebook/milsigdirect