

OWNER'S MANUAL 18 VOLT AGITATOR LOADER

This Manual Contains:

- Warranty Information
- Operating Instructions
- Maintenance Instructions
- Annotated Diagram

SPECIFICATIONS:

Power 18 Volt (requires two 9 volt batteries not included)
Capacity Approx. 180 Paintballs (88 cal)
Switching Infrared Sensor
Servo Ratio 12:1
Action Agitated gravity feed

The JT Revolution hoppers are electronically agitated paintball loaders designed for high performance and reliability. The patented design allows for the high rates of fire encountered with the modern paintball marker.

WARNING: Eye protection designed specifically for paintball must be worn by the user and persons within range. Safety is no accident.

WARNING!

GUNS AND PAINTBALL GUN ACCESSORIES ARE NOT TOYS!

- Careless use or misuse may result in serious bodily injury or death!
- Eye protection designed for paintball must be worn by the user and all persons within range.
- Must be 18 years of age or older to operate or handle any paintball gun and paintball gun accessories without adult or parental supervision.
- Read and understand all cautions, warnings, and operating manuals before using any paintball gun or paintball gun accessory.
- Do not aim paintball gun at eyes or head of people or at animals.
- Paintball guns are to be used with Paintballs only.
- To prevent fire or shock hazard, do not expose unit to rain or moisture.
- To prevent fire or shock hazard, do not immerse unit in liquids.
- To prevent fire or shock hazard, do not disassemble any electronic paintball device.
- The disposal of the battery used to power this product may be regulated in your area.
- Please conform to all local or state regulations with regard to battery disposal.
- Use common sense and have fun.

Any tampering with the unit voids your warranty. There are no consumer serviceable parts inside the unit. The use of non factory authorized components within this product may cause a critical failure, fire or shock hazard.

IN NO EVENT SHALL SELLER BE LIABLE FOR ANY DIRECT, INCIDENTAL OR CONSEQUENTIAL DAMAGES OF ANY NATURE, OR LOSSES OR EXPENSES RESULTING FROM ANY DEFECTIVE PRODUCT OR THE USE OF ANY PRODUCT.

WARNING: This product contains one or more chemicals that are known to the State of California to cause cancer and birth defects or other reproductive harm. **Wash hands after handling.**

Made in China.

▲ RULES OF SAFE PAINTBALL MARKER HANDLING

1. Treat every paintball marker as if it were loaded.
2. Never point the paintball marker at anything you don't wish to shoot.
3. Keep the paintball marker on safe until ready to shoot.
4. Keep the barrel plug in the paintball marker's muzzle when not shooting.
5. Always remove gas source before disassembly.
6. Store the paintball marker unloaded and degassed in a locked place.
7. Follow warnings listed on gas source for handling and storage.
8. Never use anything other than .68 caliber paintballs.
9. Always wear proper eye protection designed specifically to stop paintballs.
10. Never shoot a person who is not wearing proper protection.
11. Always measure velocity before playing paintball.
12. Never shoot at velocities in excess of 300 feet per second.

OPERATING INSTRUCTIONS:

CAUTION: Installing batteries incorrectly can cause damage to the circuit board!

Step 1. Insert Batteries. Slide the battery door off to insert two 9 volt batteries in through the bottom of the loader. Make sure the battery terminals are correctly oriented by noting the polarity markings that are located on the outside of the loader body and the battery door. Push on the batteries to compress the contact springs and slide the door back in place.

Step 2. Install loader on paintball marker and open spring loaded flip lid and fill through the lid opening. Leave some room for ball movement.

WARNING: Do not overfill the loader. This will cause prop jams or performance loss and could cause damage to the loader as well.

3. Switch on the power. The power switch and low-voltage indicator are located on the left side of the loader. The agitator activates when the infrared (IR) sensor does not detect a paintball in the neck of the feed tube. Once activated the prop will begin to spin until the feed tube becomes full. The IR sensor will then automatically shut the servo off.

Battery Indicator

The JT Revolution's voltage sensor circuitry will cause the LED indicator to blink and eventually glow steady as your batteries become discharged. You should replace the batteries when the LED glows steadily with the switch on and servo motor not running. You will begin losing maximum performance as your batteries deplete from this point.

STORAGE

To extend the product and battery life, always turn the power switch to off and remove the batteries during storage.

MAINTENANCE GUIDE

DISASSEMBLY

- Step 1.** Empty out any unused paintballs and remove loader from the paintball marker.
- Step 2.** Remove the feed adapter (if used), the battery door and the batteries.
- Step 3.** Remove the eight body screws from the side of the loader.
- Step 4.** Separate the two body halves of the loader and remove the flip lid and flip lid spring.
- Step 5.** Remove the main circuit board assembly, infrared circuit board, servo motor and wiring harness from the left body half.

CLEANING

Step 1. The body and flip lid may be cleaned with soap and water once they are separated from the Circuit Boards and motor. Keep moisture away from all electronic components of the JT Revolution.

Step 2. If the Circuit Boards or motor are contaminated with paint, wipe them off with a clean, dry cloth. The components can be separated if necessary by unplugging wiring harness.

REASSEMBLY

Step 1. Plug the Circuit Board back into the servo unit.

NOTE: The plugs are connected properly when the white wires face the left half of the loader.

WARNING: Improper assembly will damage electronics. See diagram below.

Step 2. Reinstall the servo unit back into left half of the loader. Make sure the switch aligns properly in this half of the loader when you have completed this step. This is to prevent pinching the wires during assembly of the two body halves.

Step 3. Install flip lid spring and flip lid into the right half of the loader.

Step 4. Carefully align the body halves together using the flip lid pin as a guide. Once the body halves are together and free of binding, snap the flip lid down in place.

Step 5. Install the eight body screws. Avoid over tightening the screws to ensure you do not strip the plastic body.

Step 6. Install the batteries and battery door. Now your JT Revolution is ready for action.

WARNING: Replace harness connectors back in location as shown. Assembling harness incorrectly will damage electronics.

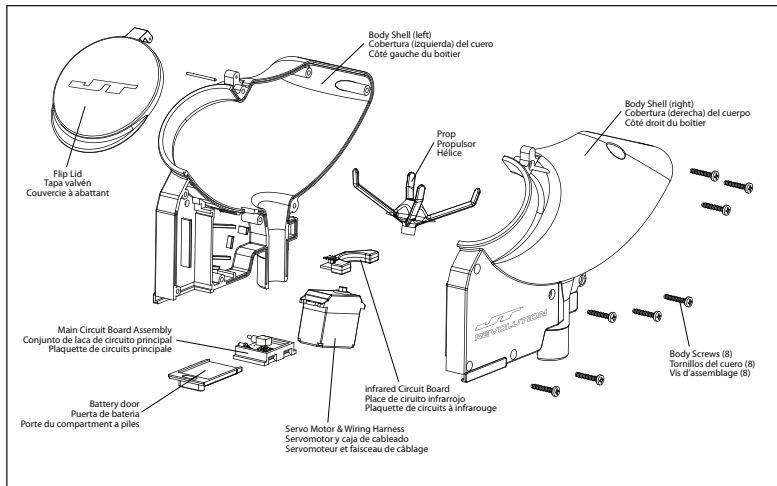
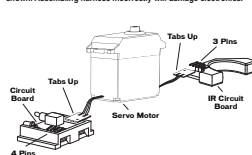

LIMITED LIFETIME WARRANTY INFORMATION

(ORIGINAL PURCHASE RECEIPT REQUIRED)

JT Paintball warrants that this product is free from defects in materials and workmanship for as long as it is owned by the original purchaser, subject to the terms and conditions set forth below. JT Paintball will repair or replace with the same or equivalent model, without charge, any of its products that have failed in normal use because of a defect in material or workmanship.

JT Paintball is dedicated to providing you with products of the highest quality and the industry's best product support available for satisfactory play.

Purchaser should register product to activate warranty. Register your product by:
 1. Online at www.paintballsolutions.com
 2. Complete the product registration card (if applicable) and mail along with a copy of your receipt to Paintball Solutions, 11723 Lime Kin Rd., Neosho, MO 64850.

WHAT THIS WARRANTY DOES NOT COVER
 This warranty does not cover problems resulting from abuse, the unauthorized modification or alteration of our product, problems resulting from the addition of aftermarket products and scratches or minor superficial imperfections. Due to the nature of paintball products it is important that the product be maintained by the user as indicated in the product manual to remain in good operating condition. Your Limited Lifetime Warranty will be void if you fail to maintain the product as recommended in the product instruction manual. In addition, certain parts of a product may be subject to wear through regular usage. Replacement and repair of such parts is the responsibility of the user throughout the life of the product.

These parts are not covered under the Limited Warranty. Examples of this type of part include (but are not limited to) goggle lens, straps, O-ring seals, cup seals, springs, ball detents, batteries, hoses, drive belts, gears and any part

of a product subject to continuous impact from paintballs. Hydrotesting of air cylinders is not covered under this warranty.

The Limited Lifetime Warranty also does not cover incidental or consequential damages. This warranty is the sole implied warranty on Empire's product and limits any implied warranty to the period that the product is owned by the original purchaser. Some states, provinces and nations do not allow the limitation of implied warranties or of incidental or consequential damages, so the above limitations or exclusions may not apply to you. This warranty gives you specific legal rights and you may also have other rights which vary from state to state, province to province, nation to nation.

If you should encounter any problems with your product and you have added aftermarket parts on your product, please test it with the original stock parts before sending it in. Always unload and remove air supply before shipping markers. Do not ship your air supply tank if it is not completely empty. Shipping a pressurized air supply tank is unsafe and unlawful. Remove all batteries from products prior to shipping.

This Limited Warranty gives you specific legal rights, and you may also have other rights which vary from state to state. Some states do not allow the exclusion of incidental or consequential damages.

For warranty parts, service or information in the U.S.

JT Paintball United States
 11723 Lime Kin Rd.
 Neosho, MO 64850
 (800)-220-3222
www.paintballsolutions.com
tech@paintballsolutions.com

JT Paintball Canada
 98 Bessamer Ct Unit 4
 London ON N6E 1K7
 (866)-685-0030
www.jpball.com

TROUBLESHOOTING CHART

For further assistance in troubleshooting your loader contact us at:

JT Paintball United States
 11723 Lime Kin Rd.
 Neosho, MO 64850
 (800)-220-3222
www.paintballsolutions.com
tech@paintballsolutions.com

JT Paintball Canada
 98 Bessamer Ct Unit 4
 London ON N6E 1K7
 (866)-685-0030
www.jpball.com

Symptom	Cause	Solution
Loader is Not Functioning or is Losing Maximum Performance	Depleted or Low Batteries	Replace Batteries
Loader is Not Operating Properly	Broken Part in the Loader	Clean the Loader
I Have Replaced Batteries and Cleaned My Loader and it Still Will Not Operate	Damaged Electronics	Visit a Local Service Center or Contact Paintball Solutions at 800-220-3222 (US)
The Loader Jams	Too Many Paintballs in the Loader or Low Quality out of Round Paintballs	Leave Some Room for Ball Movement When Filling the Loader

PATENTS: See www.paintballsolutions.com/patents ©2011-2012 KEE Action Sports. All rights reserved. The KEE Action Sports product is protected by one or more United States and International patents. KEE Action Sports Trademarks, Designs and Copyrights are protected by one or more United States patents and International Law. For more information contact KEE Action Sports at info@keesactionssports.com



