



U.S. PATENT NO. 5816232
OTHER PATENTS PENDING

This Manual Contains:

- Warranty Information
- Operating Instructions
- Maintenance Instructions
- Annotated Diagram

Specifications
 Power: 18 volts (requires two 9 volt batteries (not supplied))
 Capacity: Approx. 180 paintballs (.68 cal)
 Activation: Double Vision™ Beam IR circuit
 Feed Rate: On marker feed, up to 26bps.

WARNING: NEVER SHOOT AT ANYONE WITHOUT PROPER PROTECTIVE EQUIPMENT FOR EYES, EARS, THROAT AND HEAD, WHICH MUST BE WORN AT ALL TIMES. EYE PROTECTION MUST BE DESIGNED SPECIFICALLY FOR PAINTBALL USE. FAILURE TO FOLLOW THESE SAFETY PRECAUTIONS MAY RESULT IN BODILY INJURY INCLUDING BLINDNESS AND DEAFNESS.



Call 1-877-877-GAME (4263) or visit our web site at www.viewloader.com/service if you should need an Illustrated Parts List.



VIEWLOADER™

P.O. Box 1956, Rogers, AR 72757, U.S.A.
 877-877-GAME(4263) Fax (479)464-8701
www.viewloader.com

RULES OF SAFE PAINTBALL MARKER HANDLING

1. Always wear proper eye, face and ear protection designed especially to stop paintballs.
2. Never shoot a person who is not wearing proper protection.
3. Treat every paintball marker as if it were loaded.
4. Never look down the barrel of the marker.
5. Never point the paintball marker at anything you don't wish to shoot.
6. Keep the paintball marker on safe until ready to shoot.
7. Keep the barrel plug in the paintball markers muzzle when not shooting.
8. Always remove gas source before disassembly.
9. Store the paintball marker unloaded and degassed in a locked place.
10. Follow warnings listed on gas source for handling and storage.
11. Never use anything other than .68 caliber paintballs.
12. Do not shoot fragile objects such as windows.
13. Paintballs may cause staining of some porous surfaces such as brick, stucco and wood.
14. Always measure velocity (speed of the paintball before it exits the barrel) before playing paintball.
15. Never shoot at velocities in excess of 300 feet per second.
16. Never engage in vandalism.
17. Do not use marker for drive-by shootings.
18. Do not modify your markers pressurized air system or cylinder in any way.

OPERATION INSTRUCTIONS

(See Diagram B)

Step 1. Insert Batteries: Remove battery door screw. Slide battery door forward (see arrow) to remove. Move dual 9 volt battery harness outside the battery area and attach two new 9 volt or 9.6 volt NiMH batteries. Place batteries attached to harness into compartment. Use foam to secure battery firmly in loader compartment. Replace door into grooves on shell halves. Replace screw to hand tight.

Step 2. Install Loader: Press the neck portion of the loader into the feedport or elbow of the paintball marker as shown in direction of arrow and orient so the lid is to the rear of the marker. The neck is designed to fit most common paintball markers. The fit should be firm and tight.

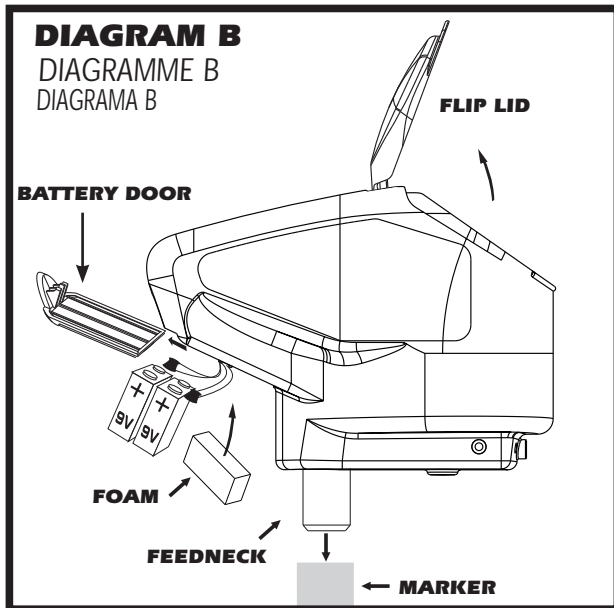

CAUTION: Do not overfill the loader! This will cause impeller jams or performance loss and could cause damage to the loader.

Step 3. Load Paintballs: Open the spring loaded lid, load paintballs leaving some room for movement. Close the lid by pressing downward until lid latches (snap shut).

Step 4. Switch on Power: The power switch, LED light, and tension micro switch are located at the rear of the loader. (See Diagram C)

Power Switch: When paintballs are loaded. (See Diagram C) Push the toggle switch to the left. Power is on LED will turn flashing green. Flashing green indicates idle mode. If the loader is empty and power is turned on the LED will be solid green indicating full speed run. To turn power to the loader off move the toggles switch to the right.

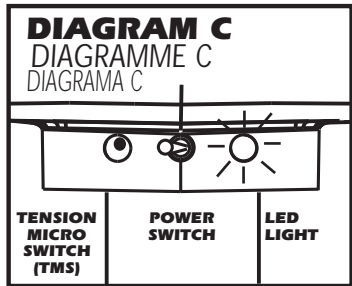

IR sensor (eyes) activation: When the center set of IR sensors are blocked by a paintball the loader will go to idle mode. When paintballs are shot, the rear (R) sensor is blocked the impeller will begin feeding paintballs. The loader will return to idle mode if no more paintballs are shot.

Low-Battery: The LED will turn solid red to indicate low battery voltage. The loader will function with low battery voltage but feed rate will not be at highest level.

Removable/upgradable Control Chip: (See Diagram F)

SelectForce® Chips As Well As Other Upgrade Chips Available But Sold Separately. Go To: www.viewloader.com for details

Auto Anti Jam Function: When the impeller arm is stopped by a jam the servo will reverse and clear the impeller. The clearing of a jam may take more than one reversing of the servo. The LED will turn orange for a moment when a jam is sensed. If excessive reversing is occurring the user will need to inspect the paintballs to determine what is causing the jam and clear paintballs or foreign objects from the loader. If you encounter several jam conditions in a loader full of paintballs you probably need to be using fresher or better quality paintballs. Note: Paintballs exposed to high temperatures can adhere to each other and will not feed in any loader. Protect your paintballs from direct sunlight and high temperatures whenever possible.

STORAGE
 To extend product and battery life, always turn the power switch off, remove the batteries, and store away from extremes in temperature and humidity.

CAUTION: USE OF ELECTRONIC CIRCUIT BOARD OR SERVO MOTOR OTHER THAN THE ORIGINAL SUPPLIED COMPONENTS MAY VOID YOUR WARRANTY. CHECK WITH VIEWLOADER BEFORE INSTALLING REPLACEMENT COMPONENTS.

CLEANING

(Diagram D) Light cleaning may be done by using a flexible/fuzzy tip squeegee or similar object such as a paper towel to clean broken paintballs from inside the loader of feed tube. If more thorough cleaning is necessary follow maintenance guide for disassembly and cleaning.

MAINTENANCE GUIDE

DISASSEMBLY (See Diagram A)

Step 1. Place a towel on a flat surface and assemble, Phillips screwdriver, flat blade screwdriver. Small cup for screws and parts.

Step 2. Remove, all screws from right side of loader. Remove single screw from left side of loader.

Step 3. Remove shells from the raceway circuit board assembly.

Step 4. (Diagram K) Remove impeller assembly.

Step 5. Remove screws from circuit board. Unplug the motor and battery harness. Separate circuit board from raceway.

IMPELLER DISASSEMBLY/REASSEMBLY:
 It is best to disassemble the loader before attempting to remove the impeller.
Step 1. (Diagram K) Remove impeller Phillips screw. Use flat blade screwdriver to lift impeller base from servo shaft. Rotate impeller and lift at several points under base.

Step 2. Remove impeller top and arms from base. Clean and lubricate spring with white grease.

Step 3. Reassemble spring to base tab as shown (Diagram K). Install impeller top and press on the servo shaft. Install Phillips screw to hand tight. Test impeller for function before reassembly of the loader. If the assembly does not spring back when under load disassemble for trouble-shooting. Reassemble with above procedure.

REASSEMBLY
Step 1 (Diagram E) Plug the wiring harness and servo motor harness back into the circuit board as shown.

Step 2. Attach motor and battery harness to connectors. Install the circuit board around feed neck, install both washers and screws. Test for correct counter-clockwise rotation. Do not over-tighten screws.

Step 3. Install assembly of step 2 into the Left shell housing and insert single raceway screw. Install lid as shown.

Step 4. Install Right side shell. Locate lid pin and lid spring correctly before installing any screws. Route battery harness wires in to groove. Install 4 long screws and single raceway screw. Test for lid and button function. Install batteries and battery door. Install battery door screw.

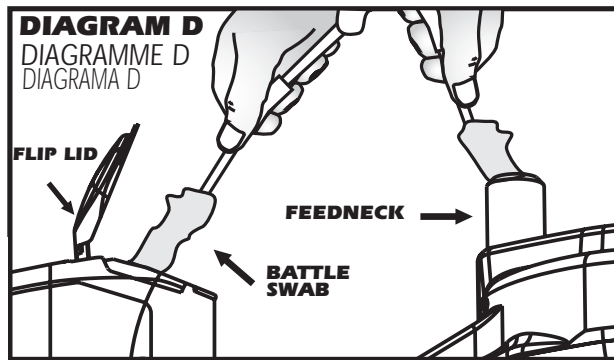

CAUTION: To prevent shorting out the wiring, check to assure no wire is crimped between servo, circuit board or housing.

NOTE: The wires from the wiring harness fit into the Left Housing. Test the direction of the impeller at this point to insure that it turns correctly in a counter-clockwise direction.

Servo Disassembly and inspection (See Diagram G) Disassemble as shown inspect Pinion Gear for excessive wear

CAUTION: To prevent shorting out the wiring, check to assure no wire is crimped between servo, circuit board or housing.

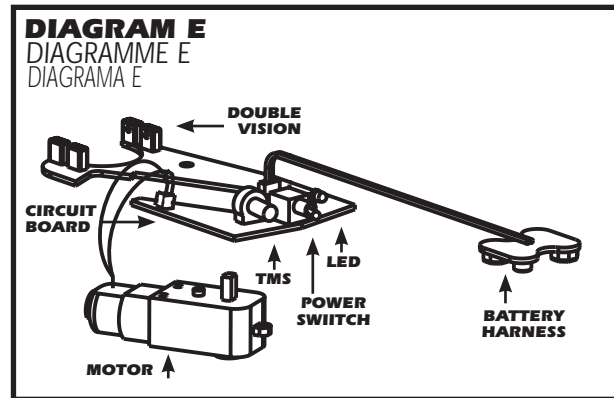

Removable / Upgradable Control Chip (See Diagram F) for correct removal and replacement of chip. Note: placement tabs must line up.

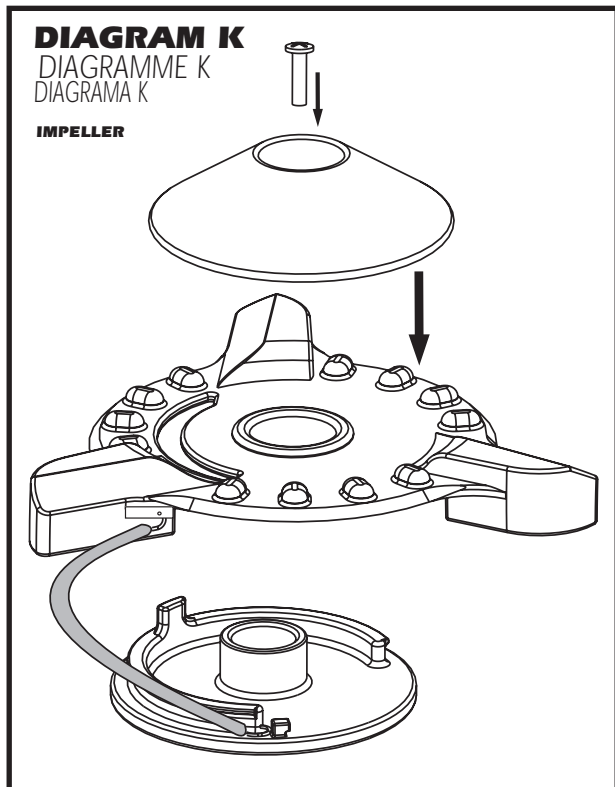
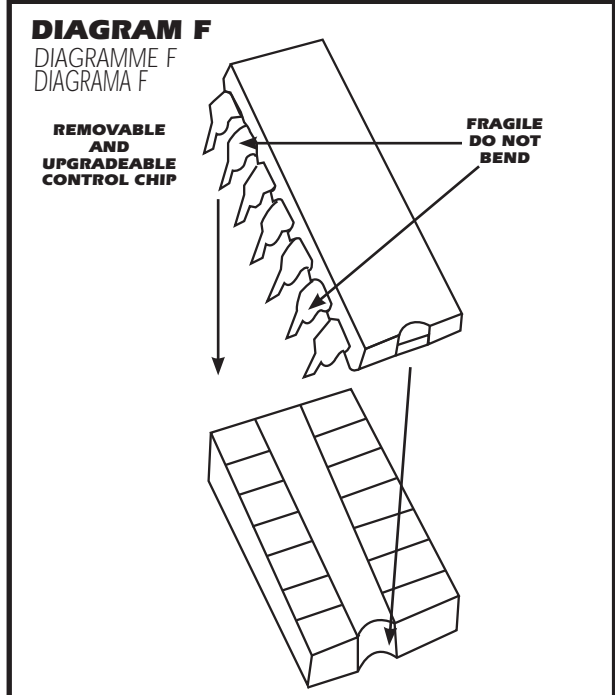
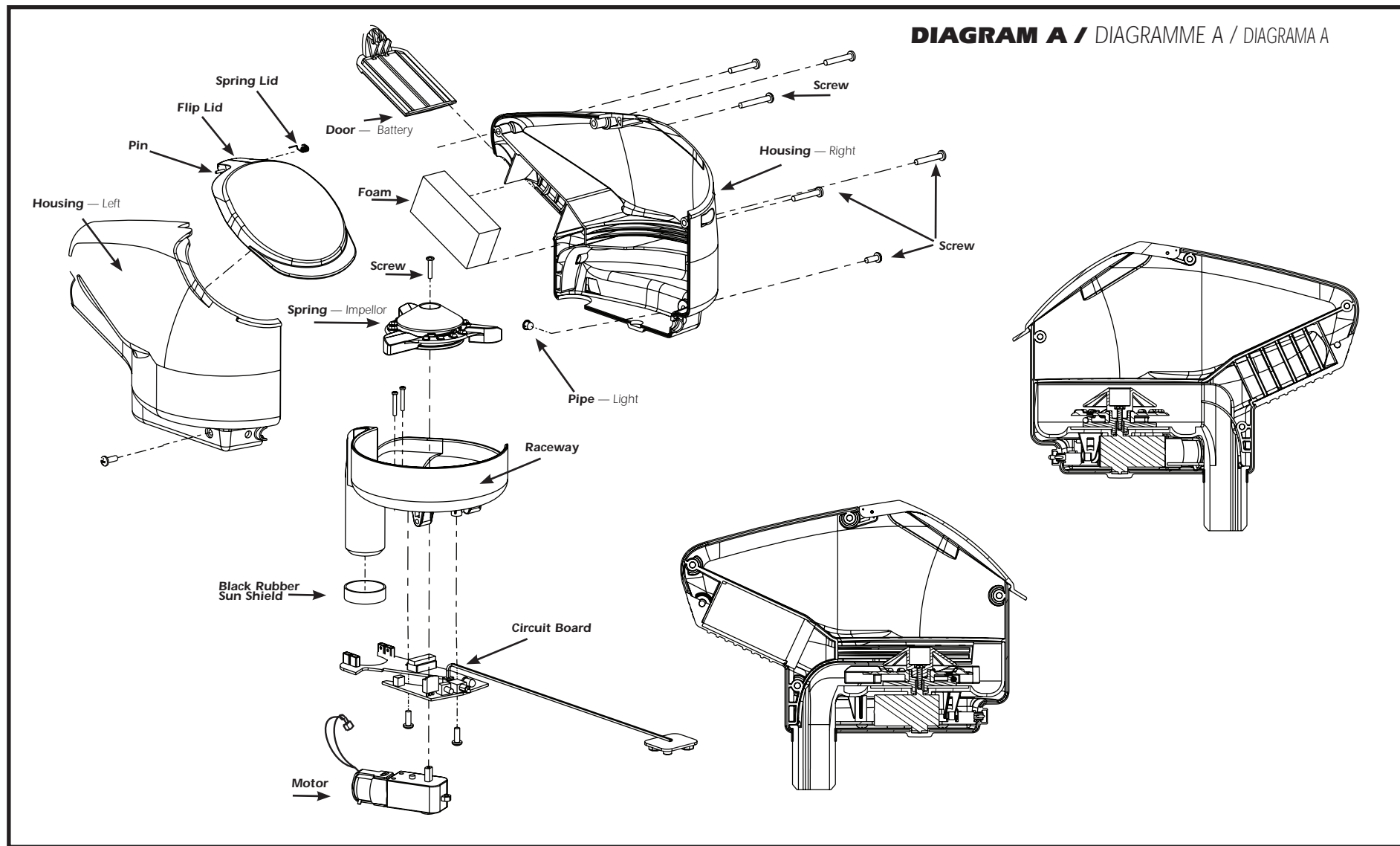
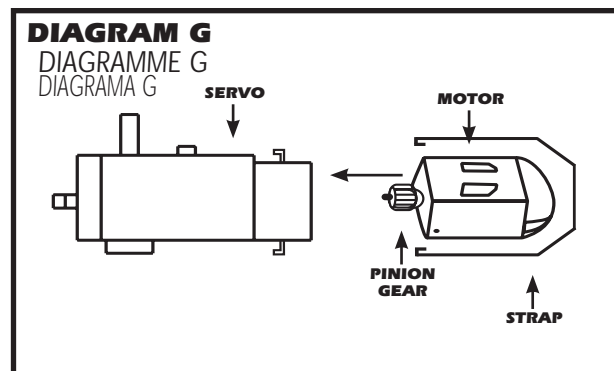

TROUBLESHOOTING CHART

For further assistance in troubleshooting your loader call Viewloader® customer service at 1-877-877-4263
 For new information on Viewloader® products and upgrades, go to www.viewloader.com

WARRANTY INFORMATION
WARRANTY: LIMITED 90 DAY WARRANTY (ORIGINAL PURCHASE RECEIPT REQUIRED)

For 90 days from date of purchase, Viewloader® will repair or replace this loader free of charge if defective in material or workmanship. This warranty gives you specific legal rights. You may also have other rights which may vary from state to state. Service is available from authorized Viewloader® Service Centers. A list of these is available at Viewloaders website at www.viewloader.com or by calling Viewloader® at 1-877-877-GAME (4263). These Service Centers generally offer the quickest service.

If you would rather return your loader to Viewloader® please call customer service at 1-877-877-GAME (4263) for return authorization number and shipping address. (Authorization number must be visible on outside of shipping package to be accepted.)

Do not return any products via non-trackable services such as regular mail or parcel post. Such products may become lost and Viewloader® Inc. will not be responsible for replacement.

PAINTBALL LOADERS OUT-OF-WARRANTY

Authorized Service Centers will gladly repair any loaders out of warranty for a nominal charge to cover parts and labor. Repairs made by Service Centers will usually be faster and less expensive than those sent back to the factory. Go to www.viewloader.com/service for service center locations near you. **Prior to shipping out of warranty loaders, you must first call customer service at 1-877-877-GAME (4263) for return authorization number and shipping address. (Authorization number must be visible on outside of shipping package to be accepted.)** Any out of warranty VLocity™ returned to Viewloader® must be shipped prepaid and include the repair fee. Please call the Customer Service number for current repair fees. Viewloader® will repair or replace the loader with a reconditioned unit of the same model. If payment is not included, you will be billed for the repair fee plus a \$4.00 invoicing fee. Upon receipt of payment, the loader or its replacement will be shipped to you. In the event that the loader includes no means of contacting the sender or no payment for repairs is received within 60 days of billing, the ownership of the loader will be forfeited and it will be disposed of at the discretion of Viewloader®.

Symptom	Cause	Solution
Loader Is Not Functioning Or Is Losing Maximum Performance	Depleted Or Low Batteries	Replace Batteries
Loader Is Not Operating Properly	Broke Paint In The Loader	Clean The Loader
LED Lights Up and Indicates Functioning but will not feed	Servo Wires are disconnected	Reattach Servo wire clip to PCBA
I Have Replaced Batteries And Cleaned My Loader And It Still Will Not Operate	Damaged Electronics	Visit A Local Service Center Or Contact Viewloader For Assistance At 877-877-GAME(4263)
I Have Taken Apart My Loader And Cleaned It. After Putting It Back Together It Will Not Function	Improper Assembly Of The Electronics or Eye Boots are Rotated Across Eyes	Reassemble The Loader Please Refer To The Electronic Assembly Diagram In Your Owners Manual
The Loader jams	Too Many Paintballs In The Loader or low quality out of round paintballs	Leave Some Room For Ball Movement When Firing The Loader
Spring Bind	Incorrectly installed	Reinstall Spring Per Spring The Diagram L

WARNING: NEVER SHOOT AT ANYONE WITHOUT PROPER PROTECTIVE EQUIPMENT FOR EYES, EARS, THROAT AND HEAD, WHICH MUST BE WORN AT ALL TIMES. EYE PROTECTION MUST BE DESIGNED SPECIFICALLY FOR PAINTBALL USE. FAILURE TO FOLLOW THESE SAFETY PRECAUTIONS MAY RESULT IN BODILY INJURY INCLUDING BLINDNESS AND DEAFNESS

International Service Center List List de Centre de Service Après-Vente International Lista de Centros de Servicio Internacionales		
Puerto Rico: Amado Gonzalez Villa Flores E-9 Urb. Los Frailes Guaynabo, PR 00969 787.790.8258 FAX: 787.720.5112 amagon@pric.net	South Africa: Paintball City South Africa P O Box 3090 Symridge 1420 27.11.828.7583 FAX: 27.11.828.7516 info@paintballcity.co.za www.paintballcity.co.za	New Zealand: Kilwell Sports 490 Te Ngae Road Rotorua 64.7.345.9094 FAX:64.7.345.5149 sports@kilwell.co.nz www.kilwell.co.nz
Canada: Kolder Canada 21 Grandview Cres. Bradford, ON L3Z 2A5 905.775.9191 FAX: 905.775.6780 sales@koldercanada.com	France: Sport Attitude 21 Avenue Rhin at Danube 72201 La Fleche Cedex 33.2.4348.5012 FAX: 33.2.43485005 www.sport-attitude.com	Brazil: Mercenarios Rua Roma, 620 C.J. 124A Sao Paulo SP 05050-090 55.11.3871.1468 mercenarios@mercenarios.com.br www.mercenarios.com.br
Mexico: Security Private Planet SA de CV Blvd. Interlomas No. 5 Local G-6 Col. Lomas Anahuac Huixquilucan Estado de Mexico CP 52760 52.55.5290.8190 FAX: 52.55.5290.8353 info@xtremepplanet.com www.xtremepplanet.com	Germany: CMC Sport GmbH Am Warftfeld 1 61169 Friedberg 49.6031.73.75.0 FAX: 49.6031.73.75.19 info@cmc-sport.com www.cmc-paintball.com	Japan: K2 Japan Corporation A Nishi-Sando Yamaki Bldg 3 28 6 Yoyogi Shibuya-ku Tokyo 151-0053 81.3.3320.7822 FAX: 81.3.3320.8771 www.k2japan.com

