



PLANET ECLIPSE: MG 100

USER MANUAL / ENGLISH

MG 100



AIR



68 CAL



SHAPED ROUND
COMPATIBLE

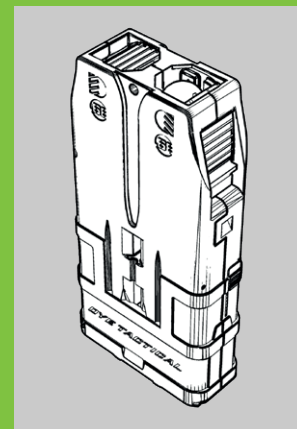
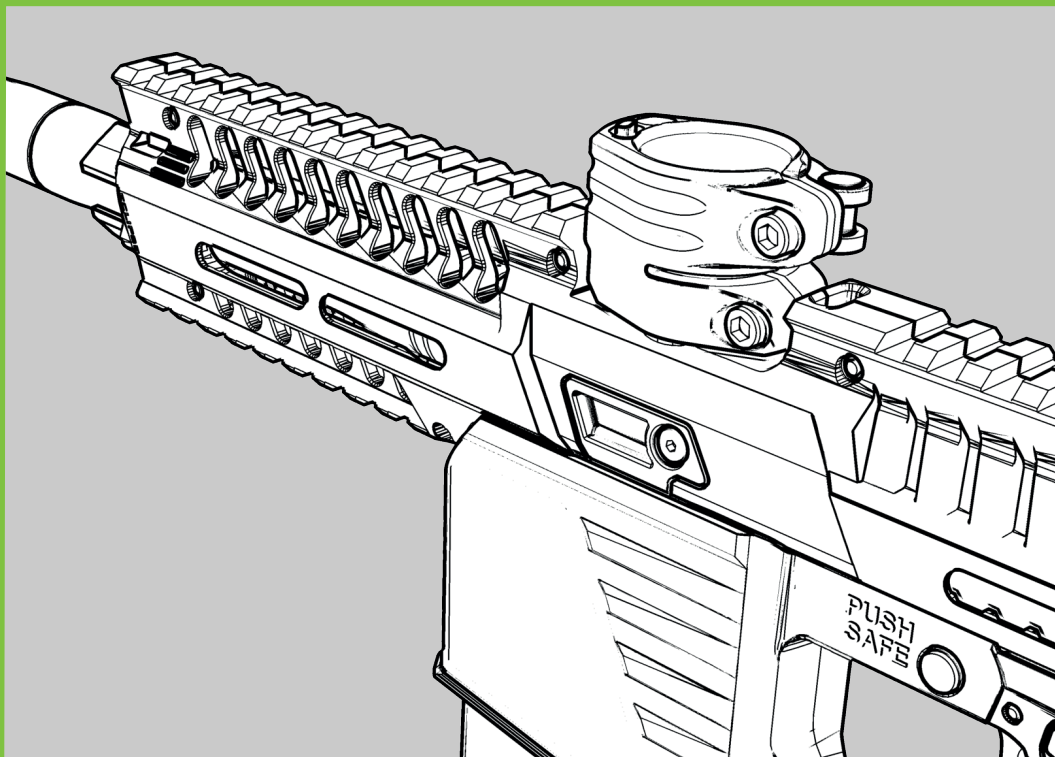

WARNINGS

READ CAREFULLY BEFORE USE

! THE PLANET ECLIPSE MG 100 IS NOT A TOY. PAINTBALL SAFETY RULES MUST BE FOLLOWED AT ALL TIMES.

! Careless or improper use of the MG 100, including failure to follow instructions and warnings within this User Manual could cause serious injury or death.

! Do not remove or deface any warnings attached to the MG 100.

! Paintball industry standard eye/face/ear and head protection designed specifically to stop paintballs and meeting ASTM standard F1776 (USA) or CE standard (Europe) must be worn by the user and any person within range. Proper protection must be worn during assembly, cleaning and maintenance.

! Hearing protection should be worn.

! Never shoot at a person who is not wearing proper protection.

! Never look directly into the barrel of the marker. Accidental discharge into the eyes may cause permanent injury or death. Never look into the barrel or breech area of the MG 100 whilst the marker is switched on and able to fire.

! Keep the MG 100 in SAFE mode until ready to shoot.

! Treat every marker as if it is loaded and ready to fire.

! Always fit a barrel-blocking device to the MG 100 when not in use.

! Always remove paintballs from the MG 100 when not in use.

! Do not field strip or remove any parts while the marker is pressurised.

! Do not pressurise the MG 100 without all the components of the marker correctly installed, as high-pressure gas may be emitted.

! Do not fire the MG 100 without the bolt correctly installed.

! Never put your finger or any foreign objects into the paintball feed tube or magazine well of the MG 100.

! Never allow pressurised gas to come into contact with any part of your body.

! Always remove the first stage regulator and relieve all residual gas pressure from the MG 100 before disassembly.

! Always remove the first stage regulator and relieve all residual gas pressure from the MG 100 for transport and storage.

! Always follow guidelines given with your first stage regulator for safe transportation and storage.

! Always store the MG 100 in a secure place.

! Observe all local and national laws, regulations and guidelines.



WARNINGS

READ CAREFULLY BEFORE USE

- ⚠ Persons under 18 years of age must have adult supervision when using or handling the MG 100.
- ⚠ Use only professional paintball fields where codes of safety are strictly enforced.
- ⚠ Use compressed air/nitrogen only. Do not use any other compressed gas or pressurised liquid including CO2.
- ⚠ Always follow instructions, warnings and guidelines given with any first stage regulator you use with the MG 100.
- ⚠ Use the calibre of paintballs or shaped rounds that are correct for your marker calibre (0.68ca).
- ⚠ Always measure your marker's velocity before playing paintball, using a suitable chronograph.
- ⚠ Never shoot at velocities in excess of 300 feet (91.44 metres) per second, or at velocities greater than local or national laws allow.
- ⚠ Any installations, modifications or repairs should be carried out by a qualified individual at a licensed and insured paintball facility.

WARNING!



This user manual must accompany the product in the event of resale or new ownership. Should you be unsure at any stage you must seek expert advice.



This Users Manual is in English.

It contains important safety guidelines and instructions. Should you be unsure at any stage, or unable to understand the contents of this manual you must seek expert advice.



Le mode d'emploi est en Anglais.

Il contient des instructions et mesures de sécurité importantes. En cas de doute, ou s'il vous est impossible de comprendre le contenu du mode d'emploi, demandez conseil à un expert.



Este manual de usuarios (operarios)

Usuarios está en Inglés. Contiene importantes normas de seguridad e instrucciones. Si no está seguro de algún punto o no entiende los contenidos de este manual debe consultar con un experto.



Diese Bedienungs - und Benutzeranleitung ist in Englisch.

Sie enthält wichtige Sicherheitsrichtlinien und -bestimmungen. Sollten Sie sich in irgendeiner Weise unsicher sein, oder den Inhalte dies Heftes nicht verstehen, lassen Sie sich bitte von einen Experten beraten.

04 CONTENTS

QUICK START (06 - 30)

06	Setting up the MG 100 - MagFed
08	Setting up the MG 100 - Hopper Fed
10	The MG 100 safety button
12	Changing between MagFed and Hopper Fed
14	Inserting the magazine
15	Removing the magazine
16	Loading / Reloading
17	Changing magazine springs
18	Attaching a PAL loader system
19	Attaching a generic loader
20	Attaching a front shroud
21	Accessory mounting
22	Attaching a stock
24	Velocity adjustment
25	Detents
26	Unloading the MG 100 - MagFed
28	Unloading the MG 100 - Hopper Fed
30	Storage and transportation

MAINTENANCE (31 - 33)

31	On-line maintenance videos
32	Fault-finding tables

TECHNICAL (34 - 43)

34	Parts list
36	MG 100 inline regulator
37	Three-way assembly
38	Bolt assembly (68cal)
39	Push On Purge System
40	Frame assembly
41	Feedneck and PAL plunger
42	Two-piece grips
43	Magazine

SUPPORT (44 - 49)

44	Our promise
45	Index
46	Notes
47	Warranty Registration Card
49	Notes



WE GOT YOUR BACK!!!

OUR ARMY OF PLANET ECLIPSE PRO TECHS ATTEND PAINTBALL EVENTS ALL OVER THE WORLD TO MAKE SURE THAT YOU AND YOUR ECLIPSE MARKER ARE FIRING ON ALL CYLINDERS, AT ALL TIMES, IN ALL GAME SCENARIOS.



FOLLOW OUR OFFICIAL PLANET ECLIPSE SOCIAL MEDIA CHANNELS TO KEEP UP TO DATE WITH OUR TECH SUPPORT EVENTS CALENDAR.

QUICK START

SETTING UP THE MG 100 MAGFED

FIG-1

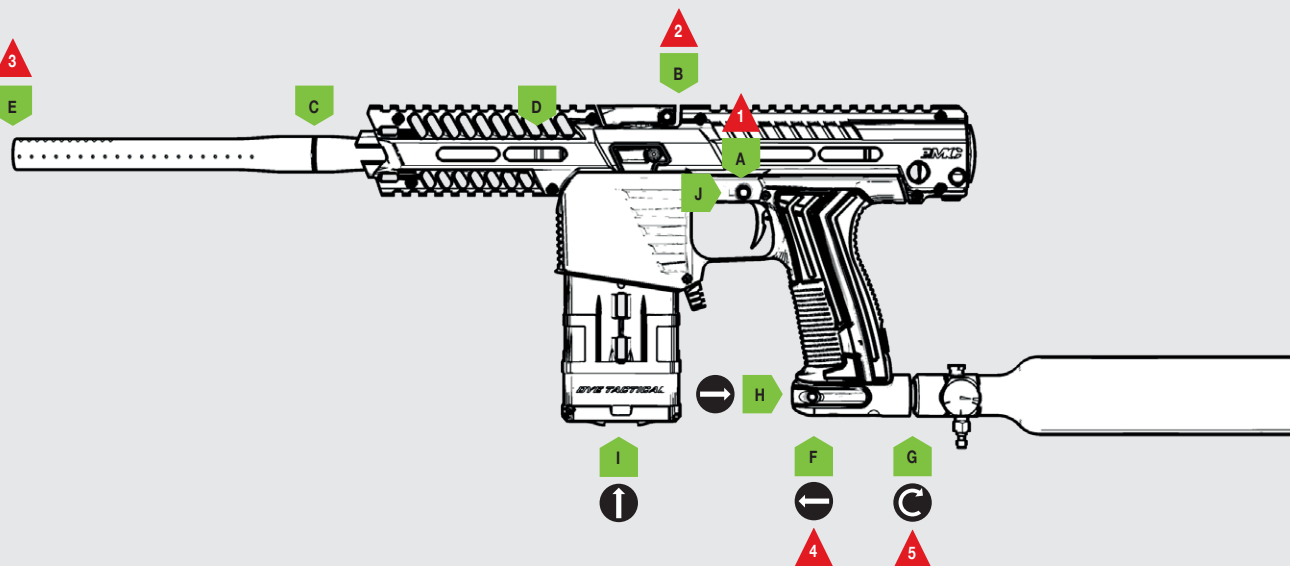

QUICK START

SETTING UP THE MG 100 MAGFED

FIG-1

- A Push the safety button to SAFE before you begin.**
- B Make sure the MG 100 is in Magfed mode.**
Insert the feedtube plug (see pages 12-13).
- C Connect both parts of the barrel together.**
Rotate the barrel tip counter-clockwise onto the barrel back.
- D Attach the complete barrel to the marker.**
Rotate the barrel clockwise into the marker body.
- E Attach a barrel blocking device for safety.**
- F Ensure the marker is de-gassed.**
Push in and hold the POPS button and pull the POPS bonnet away from the POPS body.
- G Attach the preset air system.**
Rotate the air system clockwise into the ASA body.
- H Gas the marker.**
Push the POPS bonnet into the POPS body until it engages.
- I Insert magazine into magazine well.**
Make sure the magazine clicks securely into place.
- J Push the safety button to FIRE.**
The marker will now fire when the trigger is pulled.

- 1 IMPORTANT!** To enable SAFE/FIRE see pages 10-11.
- 2 IMPORTANT!** The feedtube plug must be fitted correctly for the MG 100 to operate in magfed mode.
- 3 IMPORTANT!** Safety precaution if marker fires accidentally.
- 4 IMPORTANT!** Always ensure marker is de-gassed when setting up.
- 5 NEVER** use CO2. Only use compressed air or Nitrogen.

WARNING!



Always make sure that the marker is in SAFE mode with a barrel blocking device installed and that no paintballs are in the MG 100 or magazine before attaching an air system.

Compressed air and nitrogen systems can be extremely dangerous if handled or used incorrectly.

Only attach an air system certified for use within the country of use.

Never add lubricants or grease into the fill adaptor of the air system regulator.

Ensure that all screws are tightened and no parts are loose before installing an air system.

Do not pressurise the MG 100 without the bolt system correctly installed, as high pressure gas will be emitted.

Do not install a compressed air system or load paintballs into the MG 100 until you feel confident with your ability to handle the marker safely and responsibly.

QUICK START

SETTING UP THE MG 100 HOPPER FED

FIG-1

- A Push the safety button to SAFE before you begin.**
- B Make sure the MG 100 is in hopper fed mode.**
Attach the PAL feedneck (see pags 12-13).
- C Insert the dummy magazine into magazine well.**
Make sure the magazine clicks securely into place.
- D Secure the dummy magazine.**
Push the dummy magazine latch up to lock into place.
- E Connect both parts of the barrel together.**
Rotate the barrel tip counter-clockwise onto the barrel back.
- F Attach the complete barrel to the marker.**
Rotate the barrel clockwise into the marker body.
- G Attach a barrel blocking device for safety.**
- H Ensure the marker is de-gassed.**
Push in and hold the POPS button and pull the POPS bonnet away from the POPS body.
- I Attach the preset air system.**
Rotate the air system clockwise into the ASA body.
- J Attach PAL loader.**
If the feedneck is too tight, loosen the clamping feedneck more.
- K Gas the marker.**
Push the POPS bonnet into the POPS body until it engages.
- L Push the safety button to FIRE.**
The marker will now fire when the trigger is pulled.

- 1 IMPORTANT!** To enable SAFE/FIRE see pages 10-11.
- 2 IMPORTANT!** Hopper will not attach if PAL feedneck is not fitted.
- 3 IMPORTANT!** Safety precaution if marker fires accidentally.
- 4 IMPORTANT!** Always ensure marker is de-gassed when setting up.
- 5 NEVER** use CO2. Only use compressed air or Nitrogen.

WARNING!



Always make sure that the marker is in SAFE mode with a barrel blocking device installed and that no paintballs are in the MG 100 or loader before attaching an air system.

Compressed air and nitrogen systems can be extremely dangerous if handled or used incorrectly.

Only attach an air system certified for use within the country of use.

Never add lubricants or grease into the fill adaptor of the air system regulator.

Ensure that all screws are tightened and no parts are loose before installing an air system.

Do not pressurise the MG 100 without the bolt system correctly installed, as high pressure gas will be emitted.

Do not install a compressed air system or load paintballs into the MG 100 until you feel confident with your ability to handle the marker safely and responsibly.

10 QUICK START

THE MG 100 SAFETY BUTTON SAFE

FIG-1

The safety button **A** is located on the frame and is used to switch between safe (PUSH SAFE) and fire (PUSH FIRE).

PUSH SAFE

Push the safety button **A** in from the left side of the frame to make the MG 100 safe.

FIG-2

The button will click firmly into position **B** and will sit flush with the frame. The trigger will be locked and the marker will not fire.

! **IMPORTANT!** If the safety button does not work contact your local Eclipse Dealer immediately and do not use the marker.

WARNING!



When SAFE is enabled the MG 100 is still a live marker until the air system has been fully removed.

Ensure that a barrel blocking device is always attached when the marker is set to SAFE.

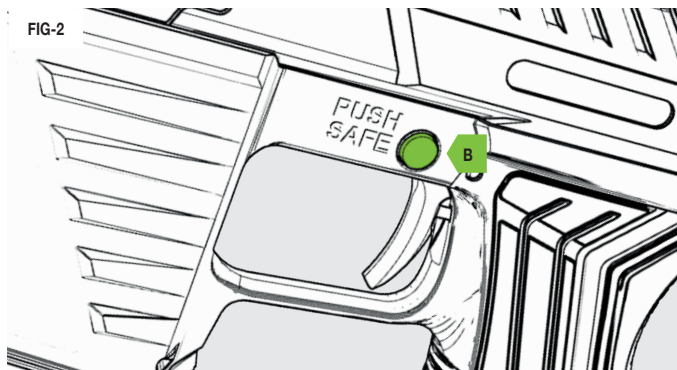

QUICK START

THE MG 100 SAFETY BUTTON FIRE

FIG-1

The safety button **A** is located on the frame and is used to switch between safe (PUSH SAFE) and fire (PUSH FIRE).

PUSH FIRE

Push the safety button **A** in from the right side of the frame to make the MG 100 ready to fire.

FIG-2

The button will click firmly into position **B** and will sit flush with the frame. The trigger will be unlocked and the marker will fire.

! **IMPORTANT!** If the safety button does not work contact your local Eclipse Dealer immediately and do not use the marker.

WARNING!



When FIRE is enabled the MG 100 is live and will fire with every pull of the trigger, if an air system is fitted.

Ensure that the MG 100 is set to SAFE and a barrel blocking device is attached until you are ready to use the marker.

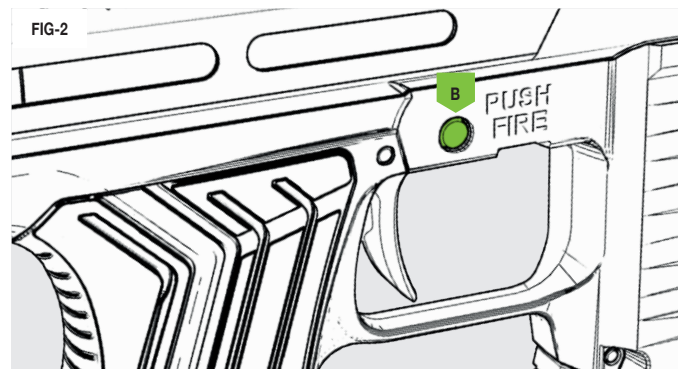
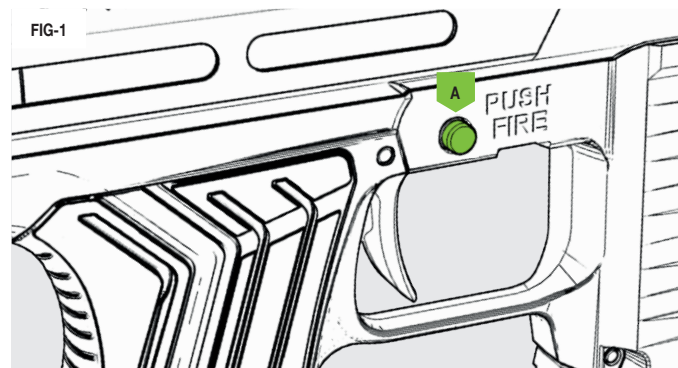

12 QUICK START

CHANGING BETWEEN MAGFED AND HOPPER FED

To switch from magazine fed to hopper fed simply follow these basic steps.

FIG-1

Locate the PAL feedtube plug screw **A**.

FIG-2

Rotate the PAL feedtube plug screw **A** counter-clockwise to remove using a 5/32 hex key.

FIG-3

Using the 5/32 hex key, bend the arms of the feedtube plug apart **B** and release the plug from the body.

FIG-4

Once released, simply pull the feedtube plug away from the body **B**.

1 **IMPORTANT!** The PAL feedtube plug will be held firmly in place so a reasonable amount of force may be required to remove.

WARNING!



The PAL feedneck feedtube plug will be secure when installed so will require an amount of force and agitation to remove it.

ALWAYS ensure that the MG 100 is degased and free from projectiles before beginning these procedures.

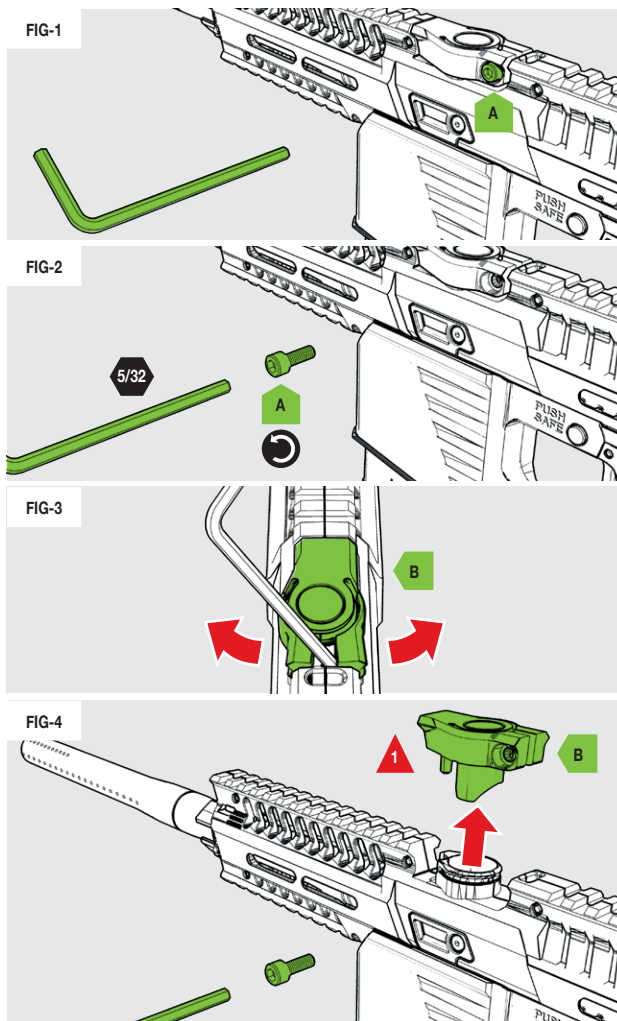

13

QUICK START CHANGING BETWEEN MAGFED AND HOPPER FED

FIG-5

Insert the PAL plunger **C** into the plunger receiver **D**.

FIG-6

Gently slide the PAL feedneck **E** over the plunger being careful not to damage it until the feedneck sits at a slight forwards leaning angle. Then push the feedneck down towards the back to level it out until it clicks into place.

FIG-7

Rotate the PAL feedtube plug screw **A** clockwise to replace it using a 5/32 hex key.

FIG-8

Insert the dummy magazine **F** into the magazine well until it clicks securely in place. Make sure the dummy magazine lock **G** is engaged, which prevents the dummy magazine latch **H** from accidentally ejecting the dummy magazine.

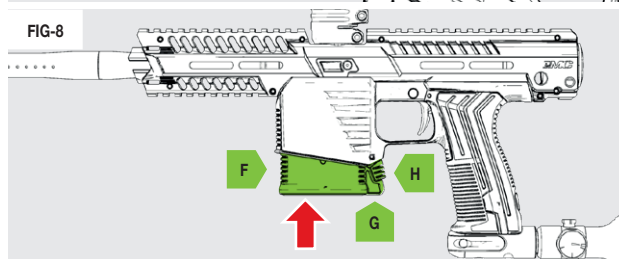
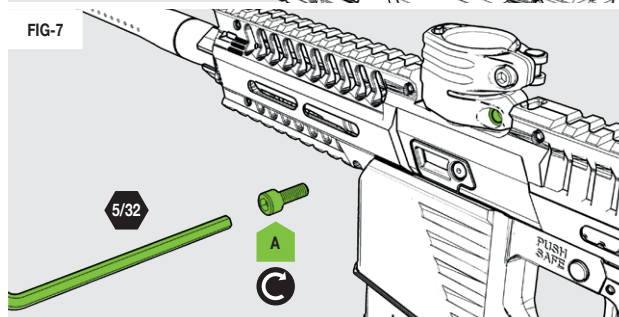
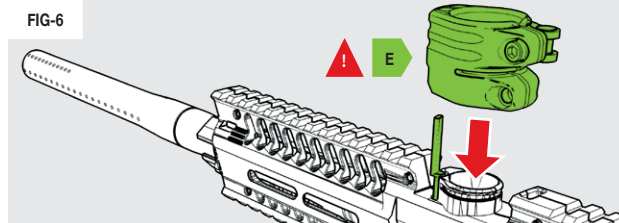
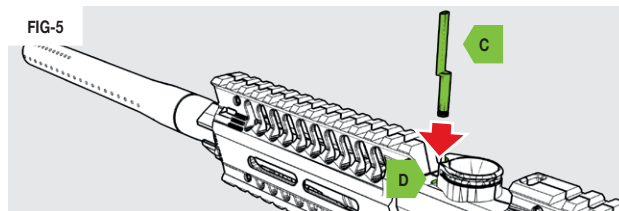

WARNING!



Take care when installing the PAL feedneck making sure not to apply too much force around the PAL plunger.

ALWAYS ensure that the MG 100 is degased and free from projectiles before beginning these procedures.

14 QUICK START

INSERTING THE MAGAZINE

FIG-1

When inserting the magazine. **A** into the magazine well, firstly make sure the magazine release latch **B** moves freely forwards and backwards between the locked and unlocked positions.

FIG-2

Push the magazine **A** firmly into the magazine well until the magazine clicks securely into place. The magazine is now engaged and ready to use.

! **IMPORTANT!** If the magazine latch is damaged the magazine will not securely engage. In this situation do not use the MG 100 and contact your local Eclipse dealer for advise.

WARNING!



Make sure the MG 100 is set to SAFE when installing a loaded magazine if you are not in a playing environment.

FIG-1

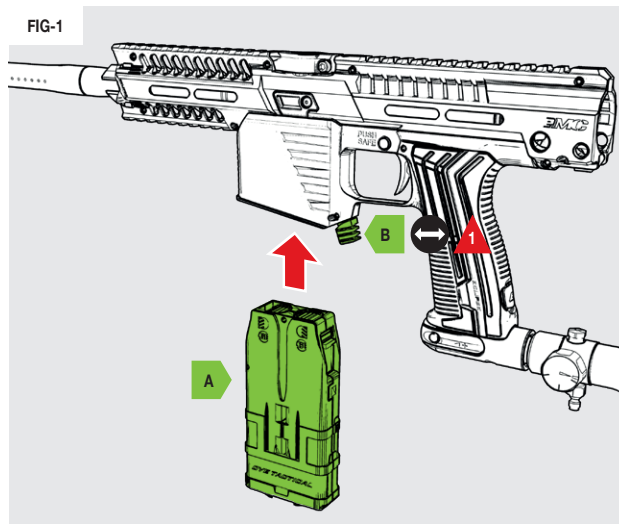
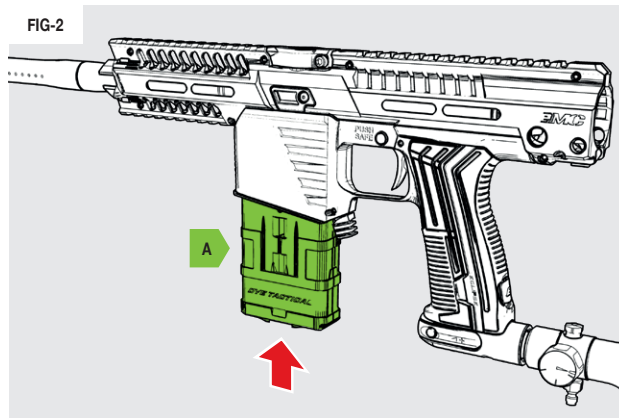

FIG-2



15

QUICK START REMOVING THE MAGAZINE

FIG-1

When removing the magazine **A** from the magazine well push and hold the magazine latch **B** inwards into the unlocked position.

FIG-2

With the magazine latch held in the unlocked position **B** pull the magazine **A** downwards until it has fully cleared the magazine well.

FIG-3

Once the magazine **A** has been fully removed release the magazine latch **B** so that it sits in the locked position (facing outwards).

! **IMPORTANT!** If the magazine latch is damaged the magazine will not securely engage. In this situation do not use the MG 100 and contact your local Eclipse dealer for advise.

WARNING!



One paintball or shaped round will be left in the marker if a magazine is removed before it has been emptied. The marker is still able to fire this paintball or round.

Make sure the MG 100 is set to SAFE when installing a loaded magazine if you are not in a playing environment.

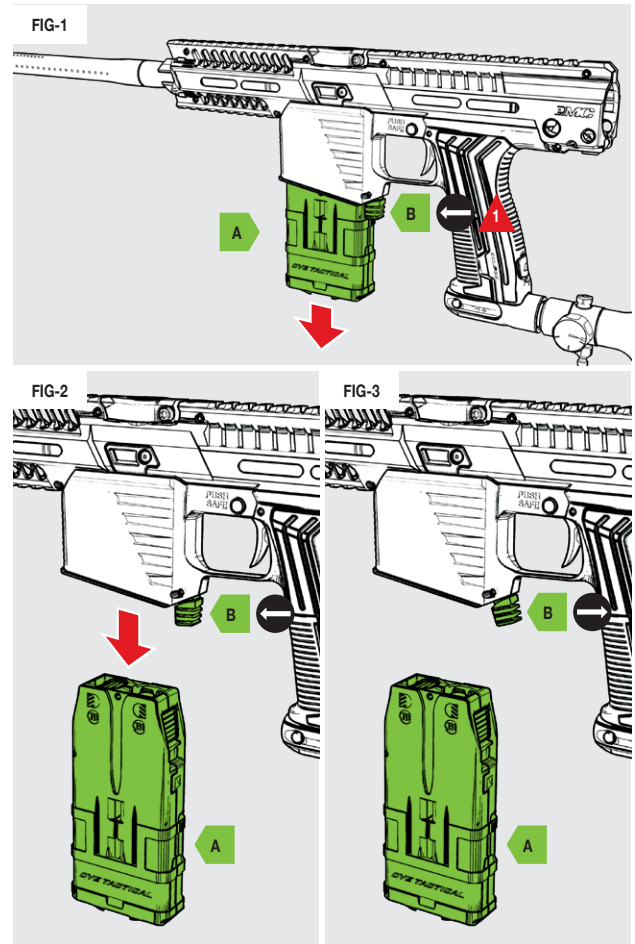

16 QUICK START LOADING / RELOADING

Loading Paintballs

FIG-1

Cover both magazine chambers with your hand then pull one magazine chamber cover **A** down to open.

FIG-2

Insert paintballs **B** one by one into the magazine chamber.

FIG-3

Once 5 or 10 rounds are loaded (capacity dependant) press gently downwards to engage the follower retainer. Next press the chamber cover release button **C** to close **A**. Repeat for the next chamber.

Loading shaped rounds

FIG-4

Repeat the process as explained in Fig-1.

FIG-5

Insert shaped rounds **D** one by one into the magazine chamber, with the front of the round facing towards the centre of the magazine.

FIG-6

Repeat the process as explained in Fig-3.

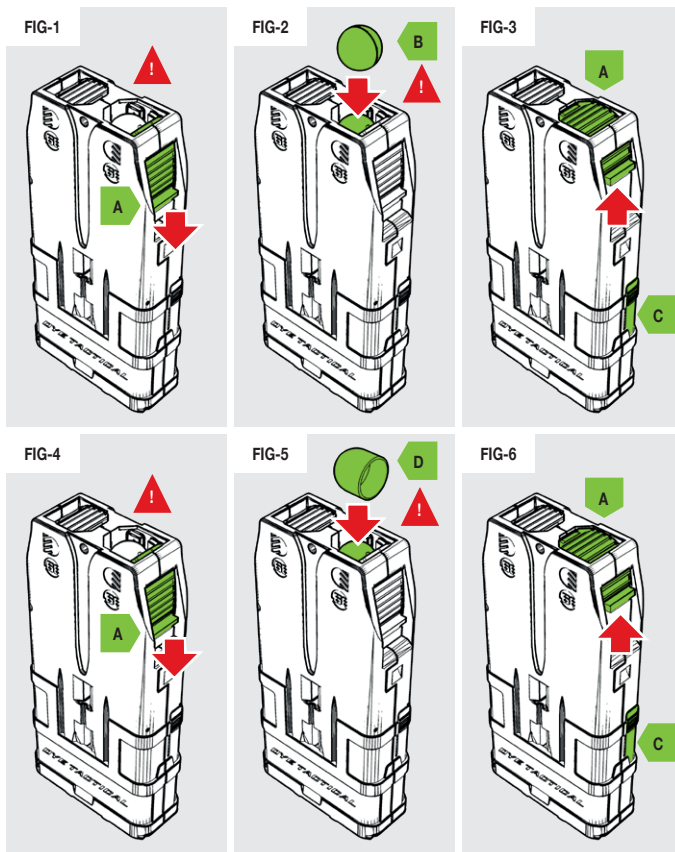

WARNING!



Loaded magazines will eject paintballs as soon as the chamber cover opens. **DO NOT** open the chamber cover while the magazine is pointed at your (or anyone's) face. For safety always place your hand over the top of a magazine before opening the chamber covers.

DO NOT depress the magazine follower without paintballs in the magazine. On rare occasions releasing a locked follower without paintballs in place can seriously damage the magazine. **NEVER** discharge a fully locked follower at yourself or anyone else.

17

QUICK START CHANGING MAGAZINE SPRINGS

FIG-1

Slide the spring retention plate **A** away from the magazine base in the direction shown on the plate. The springs **B** will pop out.

FIG-2

The followers **C** will drop to the bottom of the magazine chamber. Pull the magazine chamber cover down and the follower will drop out.

FIG-3

With the magazine upside down, fully retract each magazine chamber cover to allow the followers to fall down into the magazine. Insert the new followers **D** into position with the flat face near the top of the follower facing outwards (away from the middle of the magazine).

FIG-4

Insert the upgraded springs **E** and compress them as you slide the spring retention plate **A** in (reverse to how it was removed). Take care not to trap the springs under the spring retention plate.

FIG-5

When the Eclipse magazine follower and spring upgrade kit has been installed the followers will look as shown here **D**.

FIG-1

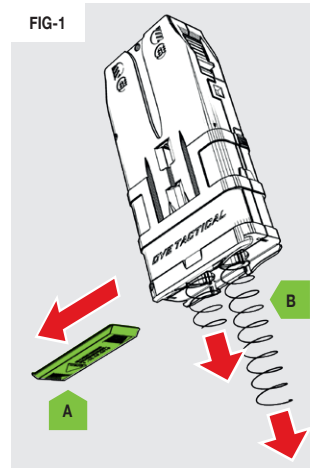

FIG-2

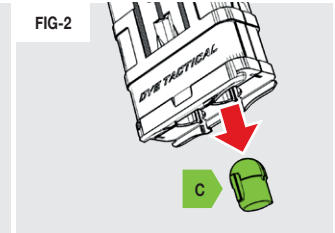

FIG-3

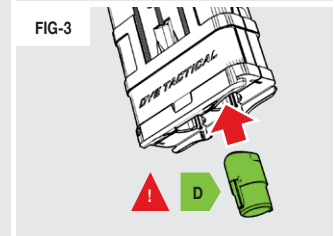

FIG-4

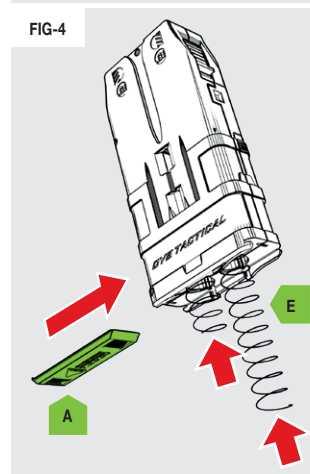
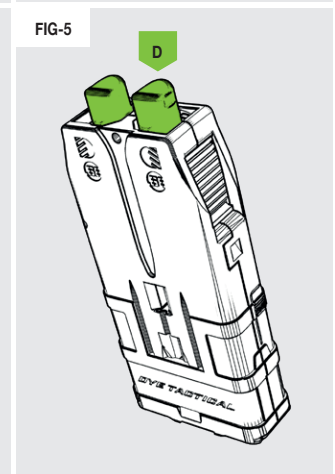

FIG-5



WARNING!



Be careful when removing springs when they're under tension.

Make sure the new followers are installed the correct way up, facing outwards.

18 QUICK START ATTACHING A PAL LOADER SYSTEM

FIG-1

Push the PAL loader **A** into the PAL feedneck assembly **B** as per any other loader. Ensure the PAL agitation plate actuator **C** aligns with the PAL plunger in the front of the PAL feedneck assembly to work correctly.

FIG-2

The PAL feedneck assembly **B** has a recess in the rear to assist with alignment of the PAL loader. When fitting the PAL loader make sure the dimple **D** sits centrally within the recess. If the PAL loader doesn't fit correctly use the clamping feedneck lever **E** to loosen / tighten accordingly.

WARNING!



If the agitator plate actuator isn't aligned with the PAL plunger then the PAL system may not work correctly.

Always make sure the marker is set to SAFE when installing a loader.

FIG-1

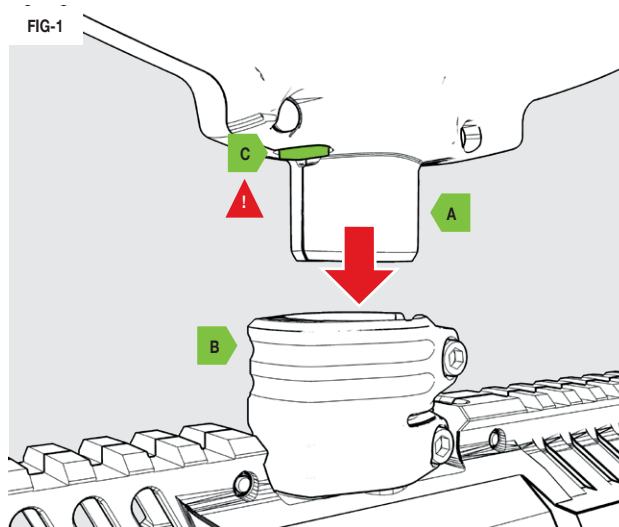
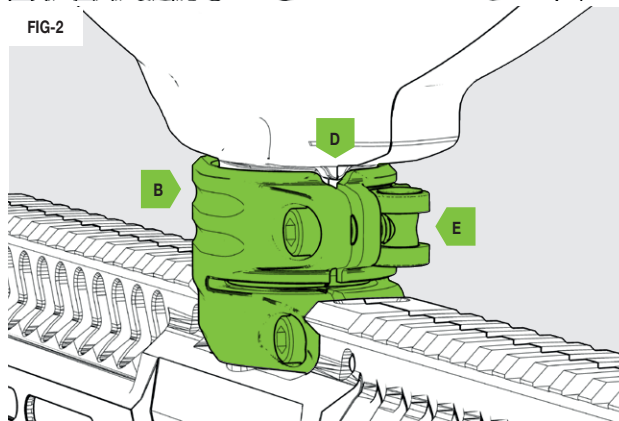

FIG-2



19

QUICK START ATTACHING A GENERIC LOADER

FIG-1

Push the loader **A** into the PAL feedneck assembly **B** as normal.

FIG-2

If the loader doesn't fit correctly use the clamping feedneck lever **E** to loosen / tighten accordingly.

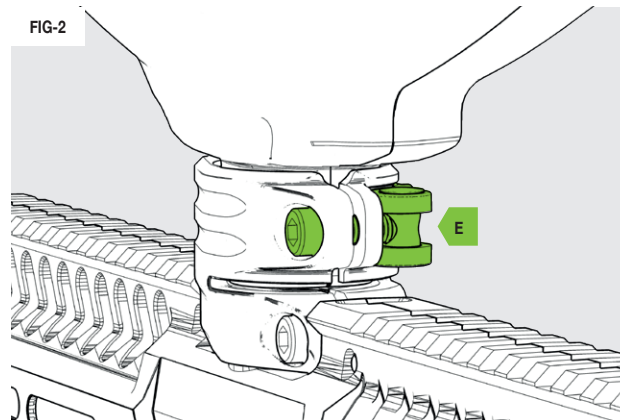
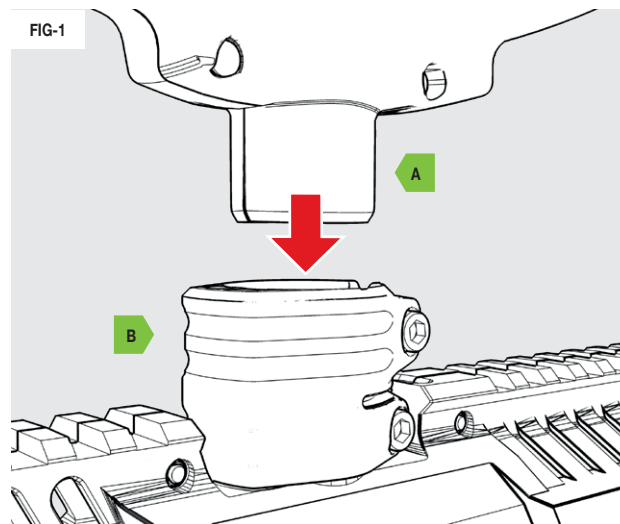

NOTICE!



Although the PAL plunger will still activate when fired, NO gas is wasted nor is the efficiency of the MG 100 affected in any way.

The PAL system WILL NOT improve the performance of non-PAL gravity-fed loaders nor will it affect the performance of any force-fed loaders.

20 QUICK START ATTACHING A FRONT SHROUD

FIG-1

To attach the front shroud and complete the full MG 100 rail kit setup simply push the front shroud section **A** over the barrel **B** and into the body section **C**. Check the angle of the connecting sections so it slots together correctly. Push together firmly so both sections fit.

FIG-2

Once the front shroud is connected to the body section insert the shroud retention clips **D** into the clip retention slots **E** on both sides of the shroud. These clips ensure both shroud sections are secure.

FIG-3

Once the retention clips **D** are in place the shroud sections are secure.

! **IMPORTANT!** The front shroud may not be compatible with third party barrel systems.

WARNING!



When removing the shroud retention clips DO NOT twist or pull at an angle as this could damage or even snap the clip stems if too much force is applied.

The shroud sections will not connect if the front shroud section is the wrong way up.

FIG-1

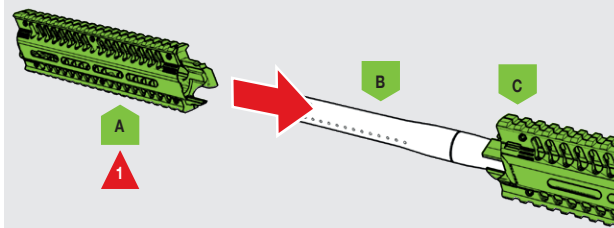

FIG-2

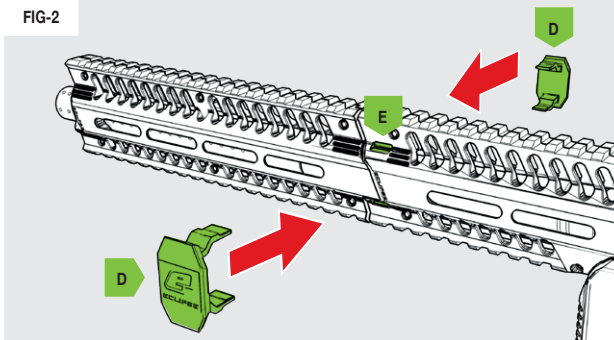
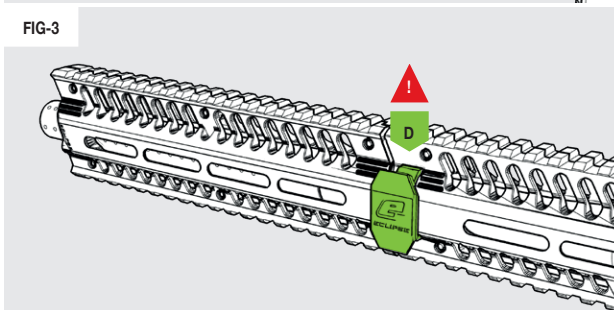

FIG-3



QUICK START

ATTACHING A STOCK

The MG 100 will only accept Tippmann98™ style stock buffer tubes using the adaptors supplied.

FIG-1

The stock **B** can be fitted to the MG 100 using the drop stock adaptor **A** and is secured using the two screws provided **C**.

FIG-2

Attach half of the drop stock adaptor **A** to the stock and hold in place.

FIG-3

Screw both halves of the drop stock adaptor together **A**.

FIG-4

The stock insert **D** is used to connect the stock and drop stock adaptor into the back of the MG 100.

FIG-5

Attach one half of the stock insert **D** to the drop stock adaptor.

FIG-6

Connect both halves of the stock insert together **D**.

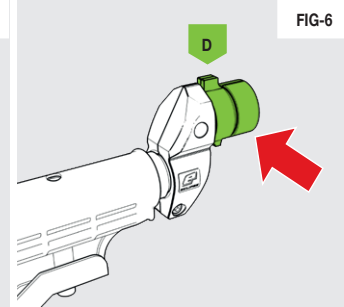
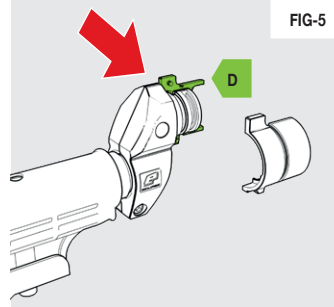
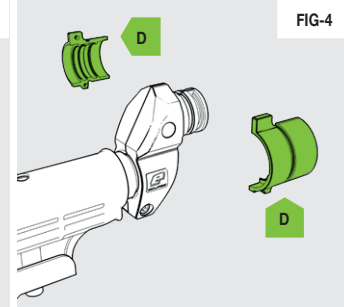
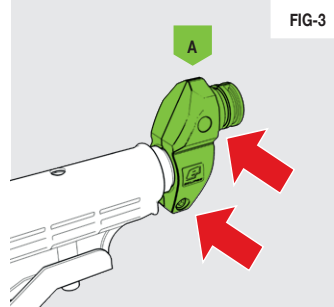
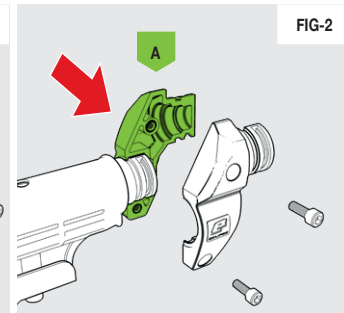
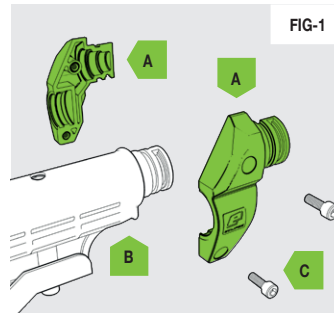

WARNING!



The drop shoulder attachment will not connect securely to the MG 100 without the addition of the stock adaptor.

The stock can be used without the drop shoulder attachment by fitting the stock adaptor directly to the stock.



23

QUICK START ATTACHING A STOCK

FIG-7

The blanking plug **E** needs to be removed from the MG 100.

FIG-8

Swing the blanking plug latch **F** towards the back of the marker to release the blanking plug.

FIG-9

The blanking plug **E** will slide out from the MG 100 body with ease.

FIG-10

Insert the stock assembly **G** into the back of the MG 100 using the top and bottom tabs to guide it. Once inserted swing the blanking plug latch **F** towards the marker to secure the stock assembly in place.

FIG-11

The installed stock assembly should be secure and solid. If it feels loose then remove and try to refit correctly.

FIG-12

Short (6mm stub) third party QD sling mounts may be installed in the mounting rings highlighted **H**.

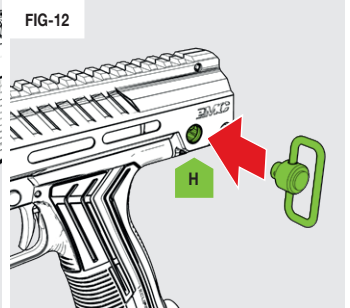
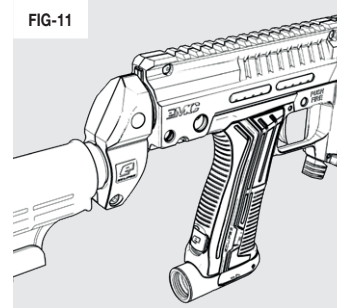
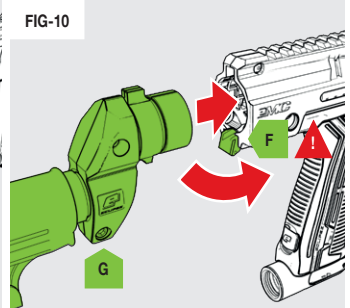
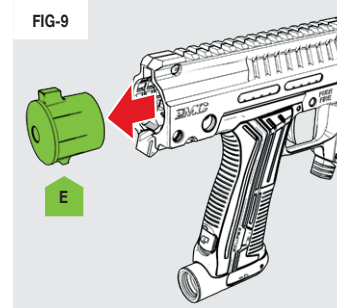
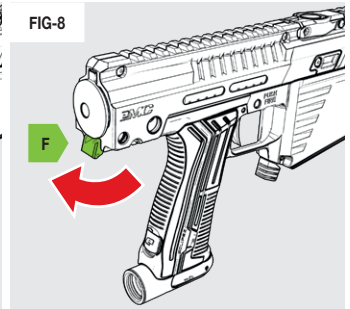
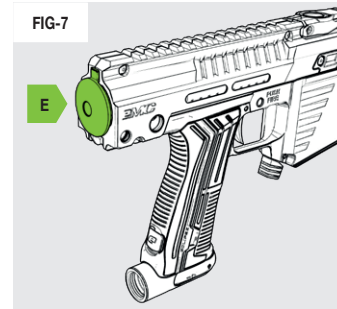

WARNING!



Always ensure the blanking plug latch is in the forwards position to guarantee the secure installation of the stock assembly.

FIG-1

Insert a 1/8 hex key **A** into the velocity adjuster screw **B** to alter the velocity of the MG 100.

Adjusting the velocity:

- 1 Turn the hex key clockwise to reduce velocity.
- 2 Turn the hex key counter-clockwise to increase velocity.
- 3 Fire two clearing shots after each velocity adjustment for an accurate velocity reading.

1 **DO NOT** turn the adjuster screw in too far. This will prevent the MG 100 from firing.

2 **DO NOT** exceed 300 FPS when using .68 calibre paintballs.

3 **DO NOT** exceed 300 FPS when using shaped rounds.

WARNING!



ALWAYS conform with the velocity limits of the venue and/or local laws.
ALWAYS wear correct protective equipment when firing your marker.
NEVER point your marker in the direction of other people when not on the field.
ALWAYS be aware of where the barrel is facing when adjusting the velocity.

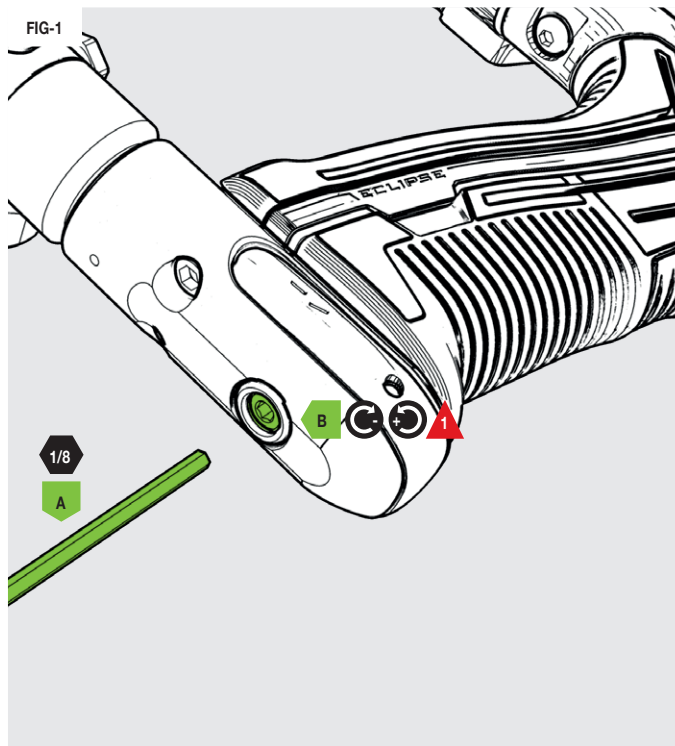

25 QUICK START DETENTS

The MG 100 rubber detents (see Fig-2) hold each paintball in place until ready to fire. This prevents paintballs from rolling down the barrel and maintains feed consistency.

These can be removed for cleaning or replacement.

FIG-1

Use a 5/64" (2mm) hex key **A** to remove the detent cover screw **B** by rotating counter-clockwise. This will release the detent cover **C** (see Fig-2).

FIG-2

To remove the detents **D** simply use a small hex key, or your finger tips, to gently lift the rubber detent from its seat.

B Detent cover screw
6-32UNC x 5/16
countersunk socket screws

C Detent cover

D Rubber detent

The elements within this diagram apply to both sides of the marker.

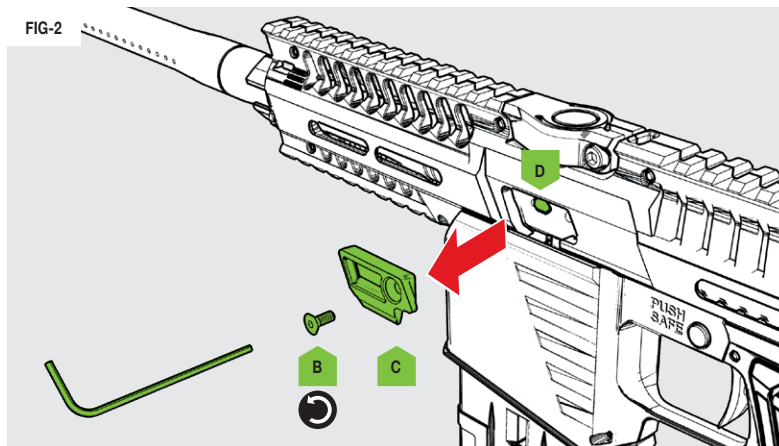
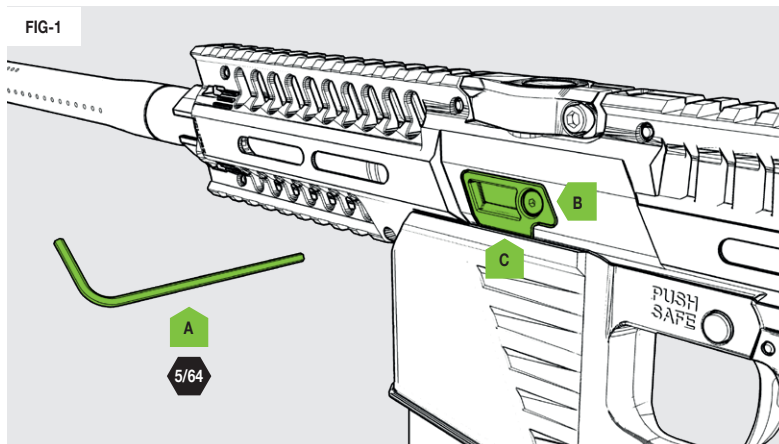

QUICK START

UNLOADING THE MG 100 MAGFED

FIG-1

A Push the safety button to SAFE before you begin unloading.

B Attach a barrel blocking device.

C Ensure the marker is de-gassed.

Push in and hold the POPS button and pull the POPS bonnet away from the POPS body.

D Remove the preset air system.

Rotate the air system counter-clockwise from the ASA body.

E Depress and hold the magazine latch.

To release the magazine from the magazine well.

F Remove the magazine.

Slide the magazine out from the magazine well.

G Ensure the breech is empty.

H Remove the barrel blocking device.

I Remove the barrel.

Rotate the barrel counter-clockwise from the marker body.

1 ALWAYS always remove rounds from the breech before handling the marker.

2 IMPORTANT! To enable SAFE/FIRE see pages 10-11.

3 IMPORTANT! Only remove air system when marker is de-gassed.

4 IMPORTANT! The magazine will not release if the magazine latch is not depressed.

5 IMPORTANT! Keep barrel blocking device attached until safe.

WARNING!



Always make sure the MG 100 is in SAFE mode with a barrel blocking device attached and that no paintballs are in the breech before unloading.

Compressed air and nitrogen systems can be extremely dangerous if handled or used incorrectly.

NEVER leave the MG 100 gassed up when unloading.

NEVER point your marker in the direction of other people when not on the field.

Remove any paintballs from the breech before storing your MG 100.

QUICK START

UNLOADING THE MG 100 HOPPER FED

FIG-1

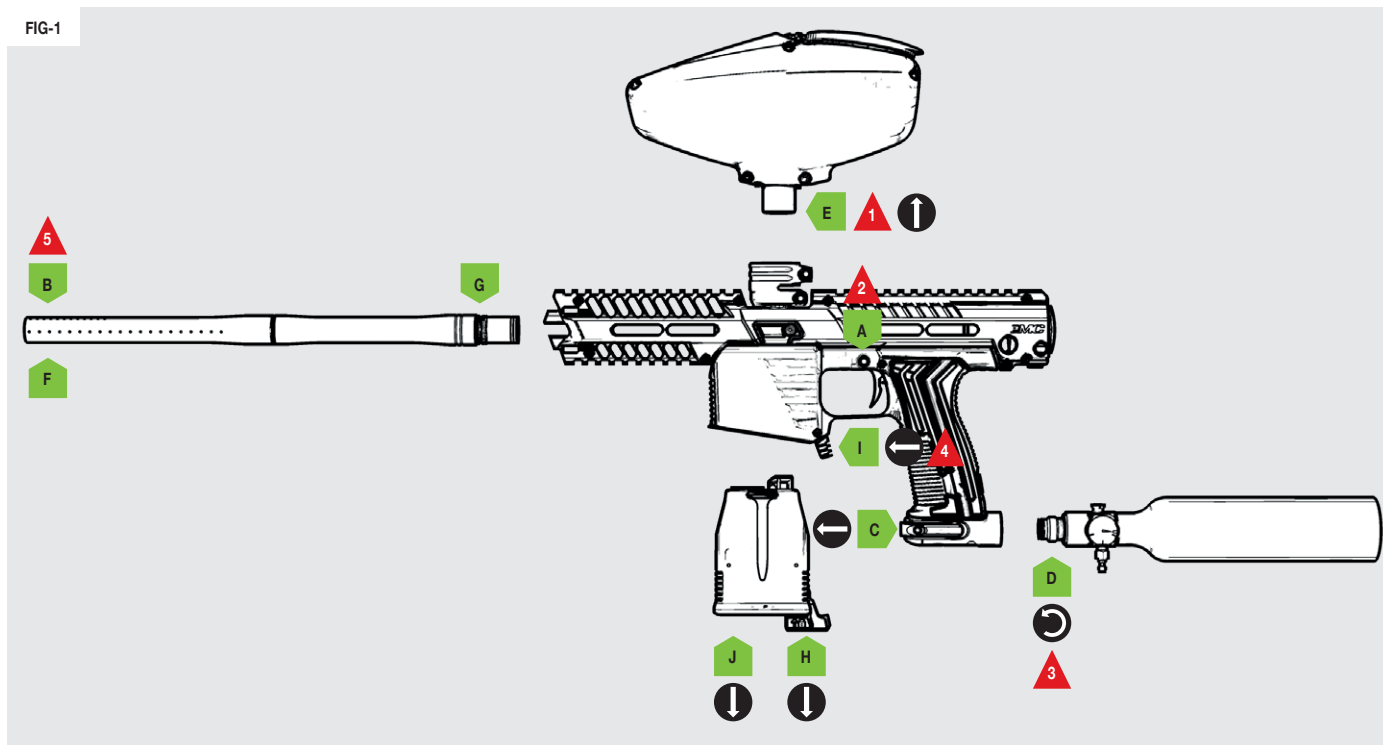

QUICK START

UNLOADING THE MG 100 HOPPER FED

FIG-1

- A Push the safety button to SAFE before you begin.**
- B Attach a barrel blocking device.**
- C Ensure the marker is de-gassed.**
Push in and hold the POPS button and pull the POPS bonnet away from the POPS body.
- D Remove the preset air system.**
Rotate the air system counter-clockwise from the ASA body.
- E Remove loader/hopper.**
Open the clamping feedneck lever to loosen.
Ensure the breech is clear of paintballs.
- F Remove barrel blocking device.**
- G Remove the barrel.**
Rotate the barrel counter-clockwise from the marker body.
- H Release the dummy magazine.**
Pull down the dummy magazine latch to enable its release.
- I Engage and hold the magazine latch.**
To release the magazine from the magazine well.
- J Remove the dummy magazine.**
Slide the dummy magazine out from the magazine well.

- 1 ALWAYS** always remove rounds from the breech before handling the marker
- 2 IMPORTANT!** To enable SAFE/FIRE see page 10-11.
- 3 IMPORTANT!** Only remove air system when marker is de-gassed.
- 4 IMPORTANT!** Magazine will not release if magazine latch is not depressed.
- 5 IMPORTANT!** Keep barrel blocking device attached until safe.

WARNING!



Always make sure the MG 100 is in SAFE mode with a barrel blocking device attached and that no paintballs are in the breech before unloading.

Compressed air and nitrogen systems can be extremely dangerous if handled or used incorrectly.

NEVER leave the MG 100 gassed up when unloading.

NEVER point your marker in the direction of other people when not on the field.

Remove any paintballs from the breech before storing your MG 100.

QUICK START

STORAGE AND TRANSPORTATION

- 1 Your MG 100 must be clear of all paint and propellant during transportation or storage.
- 2 Make sure the safety button is set to SAFE.
- 3 Remove the barrel from the marker.
- 4 Make sure the marker is clean of any paint residue, dirt and moisture.
- 5 Store your MG 100 in a clean, cool, dry place.
- 6 Keep your MG 100 away from any unauthorized or unsafe users.
- 7 Protect your MG 100 from excessive heat during transportation.
- 8 When transporting a paintball marker by air, check with the airline regarding their policies on transporting paintball equipment as hold luggage before arriving at the airport.
- 9 Observe and obey all local and national laws concerning the transportation of paintball markers.
- 10 Use the box in which the marker was originally supplied to protect the marker against rough handling during transport.
- 11 Store in a cool place away from direct sunlight and chemical fumes (such as petrol or engine exhaust gases). Long term exposure to direct sunlight, chemicals and large temperature fluctuations will damage the magazines.
- 12 Do not store your magazines in a loaded state for longer than 24 hours. Prolonged periods of spring compression can damage the springs and will reduce their effectiveness when loading.

WARNING!

Never carry your MG 100 un-cased when not on a playing field. The non-playing public and law enforcement personnel may not be able to distinguish between a paintball marker and a real firearm. For your own safety and to protect the magazine of paintball always carry the Eclipse MG 100 (or any other paintball marker) in a suitable marker case such as the one in which it was supplied.



MAINTENANCE

ONLINE MAINTENANCE VIDEOS

To demonstrate how to maintain and service essential parts of the MG 100 we've created a collection of dedicated marker maintenance videos to guide the user through each step.

From basic, to more advanced parts of the MG 100, we've got your back!

Check out the MG 100 Eclipse Tech Hub playlist at our YouTube channel for more. And don't forget to **Subscribe**.

www.youtube.com/user/planetecclipse



SYMPTOM	POSSIBLE CAUSE	SOLUTION
The MG 100 leaks from the three-way.	The gasket between the three-way body and gun body, o-ring on air transfer pipe or the gasket under the three-way plate are damaged or dirty.	Ensure the gasket is seated correctly. Replace the gaskets if damaged using MG 100 parts kit. Check condition of the air transfer pipe 010 NBR70 o-ring.
	The three-way is over-pressurised.	Check the output pressure of the inline regulator and adjust accordingly. Clean and inspect the inline regulator assembly paying particular attention to the piston tip and regulator seal. Replace damaged components as necessary.
	Damaged or incorrect seals on the three-way spool.	Replace and/or lubricate three-way spool seals.
The MG 100 leaks down the barrel.	Dirty or damaged can o-rings.	Clean and lubricate or replace 020 NBR70 and 017 NBR o-rings on the front of the can.
	Dirty or damaged o-rings on the spool.	Clean and lubricate or replace the 011 NBR70 and 012 NBR70 o-rings on the main spool.
	Dirty or damaged bolt o-rings.	Clean and lubricate or replace 14x2 NBR70 o-ring on the back of the bolt.
	Dirty or damaged rear bolt guide o-ring.	Clean and lubricate or replace 14x2 NBR70 o-ring towards the back of the bolt guide.
The marker is breaking paintballs in the barrel or breech.	The ball detents are damaged or missing.	Replace the ball detents.
	The force setting of the loader is too high (where applicable).	Reduce the loader force feed setting.
	The paint is poor quality.	Try a higher grade of paint.
	The velocity is set too high.	Check and adjust the velocity of the MG 100.
	The magazine requires maintenance.	Disassemble and clean the magazine. Replace if necessary.



SYMPTOM	POSSIBLE CAUSE	SOLUTION
The MG 100 does not fire.	The air system is not fully engaged.	Screw in the air system until it fully engages.
	The POPS bonnet is not engaged.	Make sure the POPS bonnet is pushed towards the POPS body.
	The three-way is damaged.	Replace the three-way.
Low constant velocity.	The inline regulator output pressure set too low.	Increase the output pressure of the inline regulator.
High velocity first shot.	The inline regulator pressure is creeping.	Strip and clean the inline regulator replacing the regulator seal inside the regulator adjuster assembly.
Velocity drop-off during rapid fire.	Air system regulator does not have high enough flow.	Try another air system.
	Dirty/partially blocked inline regulator.	Strip, clean, lubricate and rebuild the inline regulator.
Two or more balls are being fed into the breach.	Worn, damaged or missing ball detents.	Change the rubber ball detent.
	The feed force is too high from loader. (where applicable).	Adjust loader settings/use lower force loader.
MG 100 is inconsistent.	The inline regulator is dirty.	Strip and clean inline regulator, replace regulator seal.
	Poor quality paintballs.	Use better quality paintballs.
	Poor paintball size to barrel bore match.	Use a closer paintball to barrel bore size.
	Inconsistent air supply from air system.	Service the air system.
MG 100 is inefficient.	Poor paintball size to barrel bore match.	Use a closer paintball to barrel bore size.

If an issue with the MG 100 cannot be solved using the fault finding guide, contact your nearest Eclipse Service Centre for assistance.

FIG-1

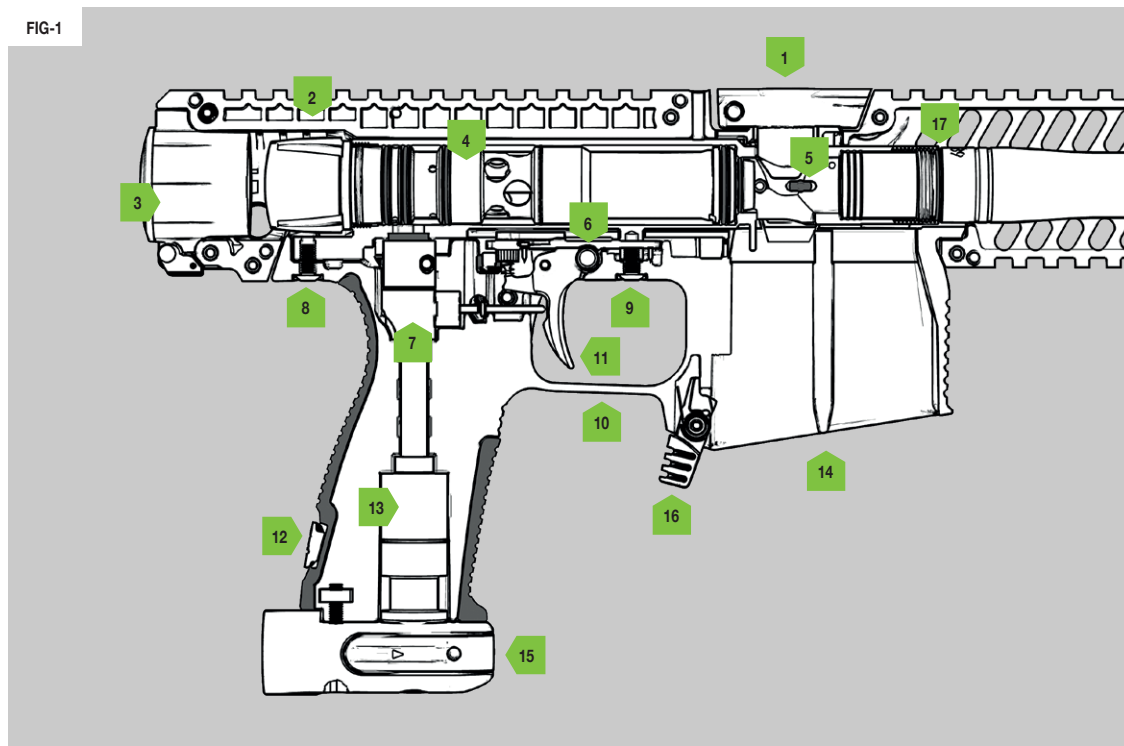

FIG-1

- | | | | |
|---|--|----|---------------------------------|
| 1 | Feedtube plug / Clamping feedtube assembly | 10 | Frame assembly |
| 2 | Marker body shell | 11 | Trigger assembly |
| 3 | Back cap | 12 | Grip retaining clip |
| 4 | Bolt assembly | 13 | Regulator assembly |
| 5 | Rubber detent | 14 | Magazine well |
| 6 | Safety switch | 15 | ASA assembly |
| 7 | Three-way assembly | 16 | Magazine release catch assembly |
| 8 | Rear frame screw | 17 | Barrel o-ring #016 NBR70 |
| 9 | Front frame screw | | |

FIG-1

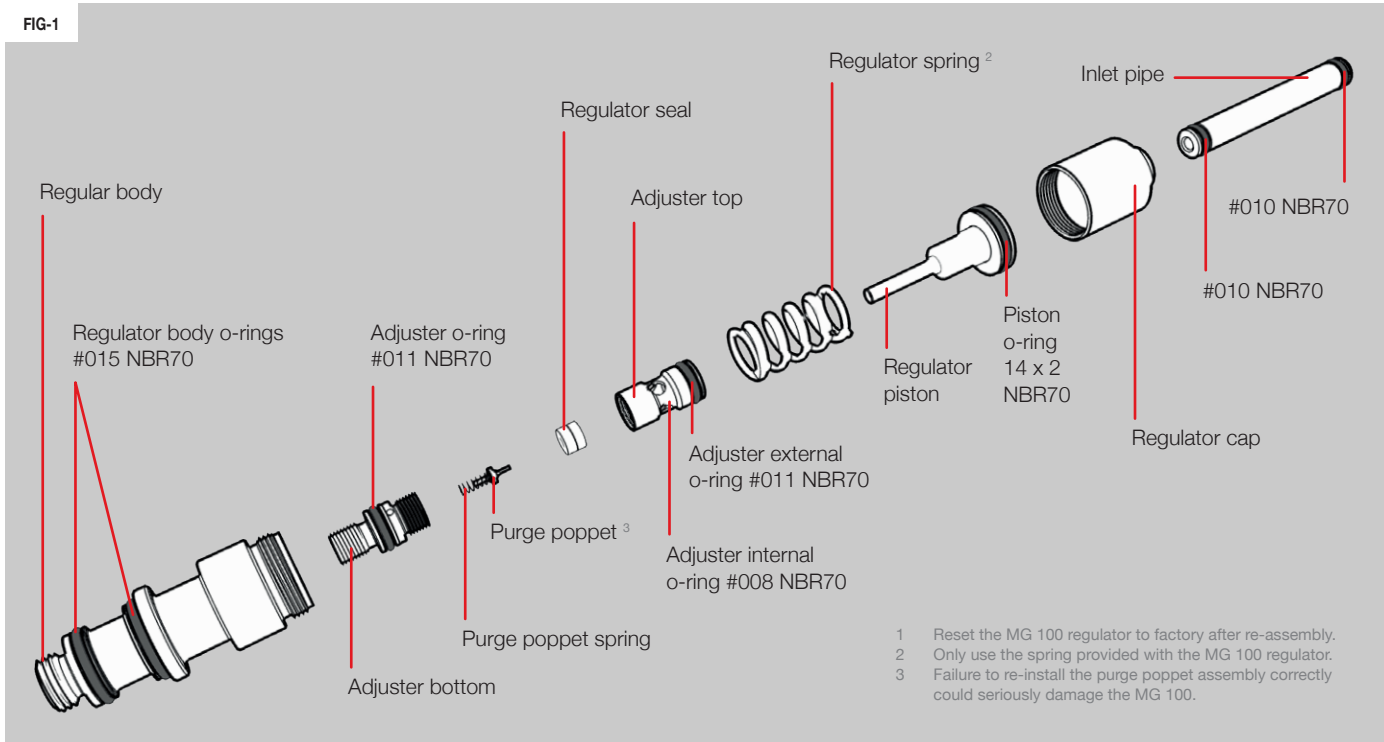
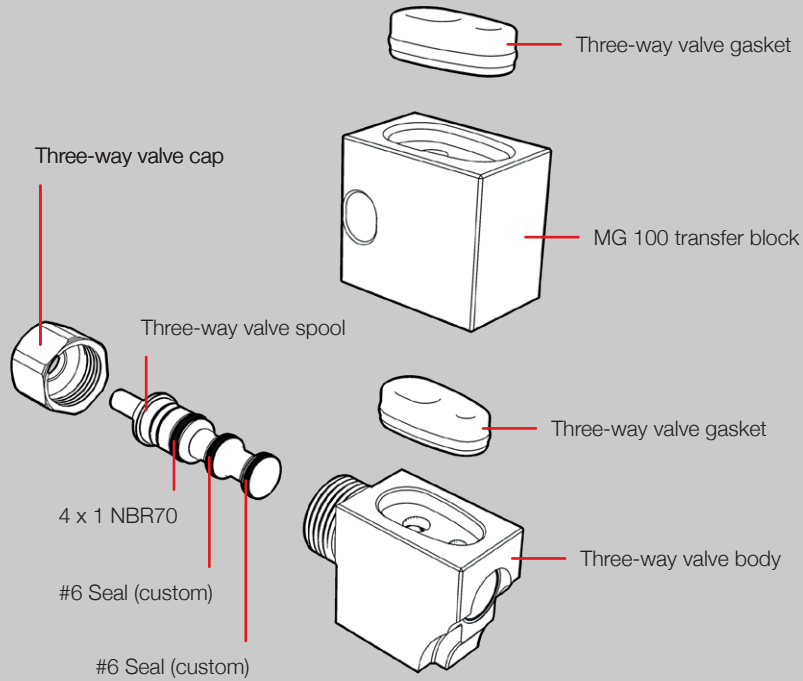
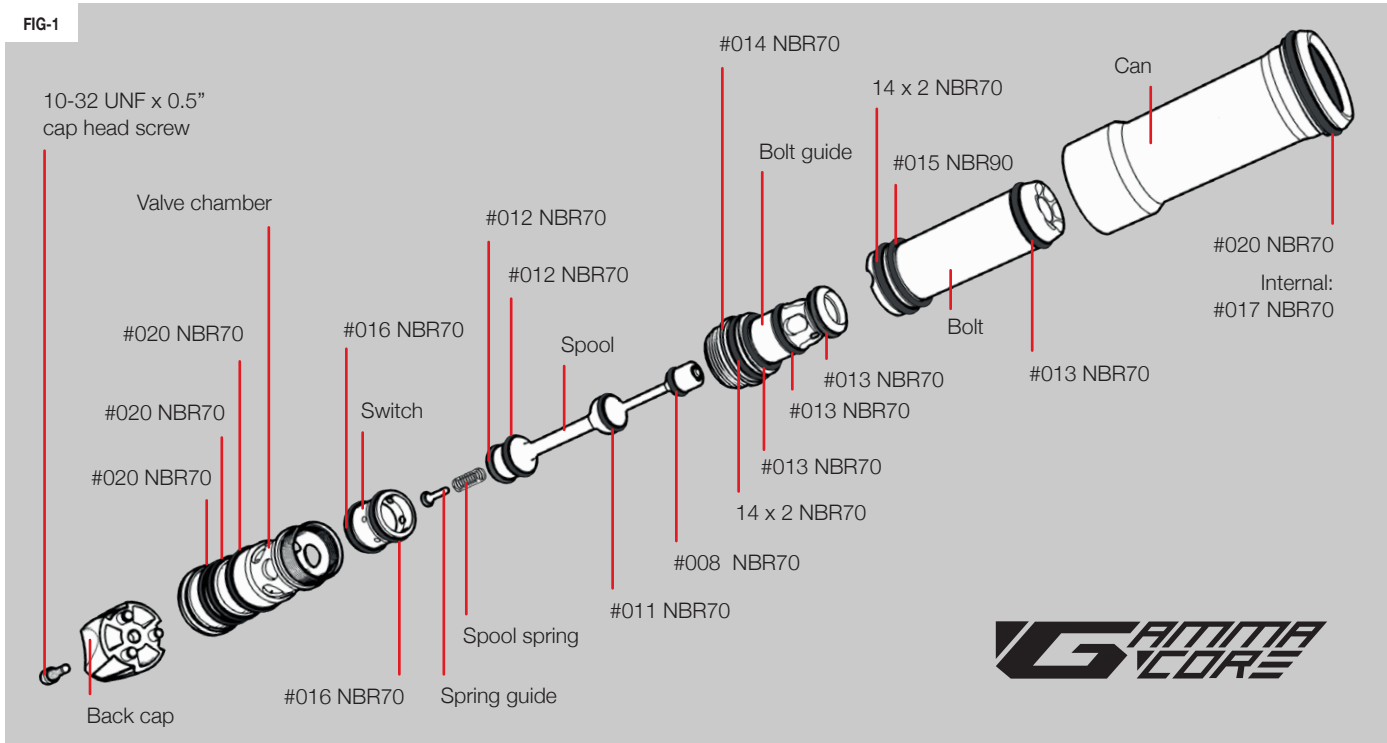

FIG-1



TECHNICAL BOLT ASSEMBLY (68CAL)

FIG-1



TECHNICAL

PUSH ON PURGE SYSTEM (POPS)

FIG-1

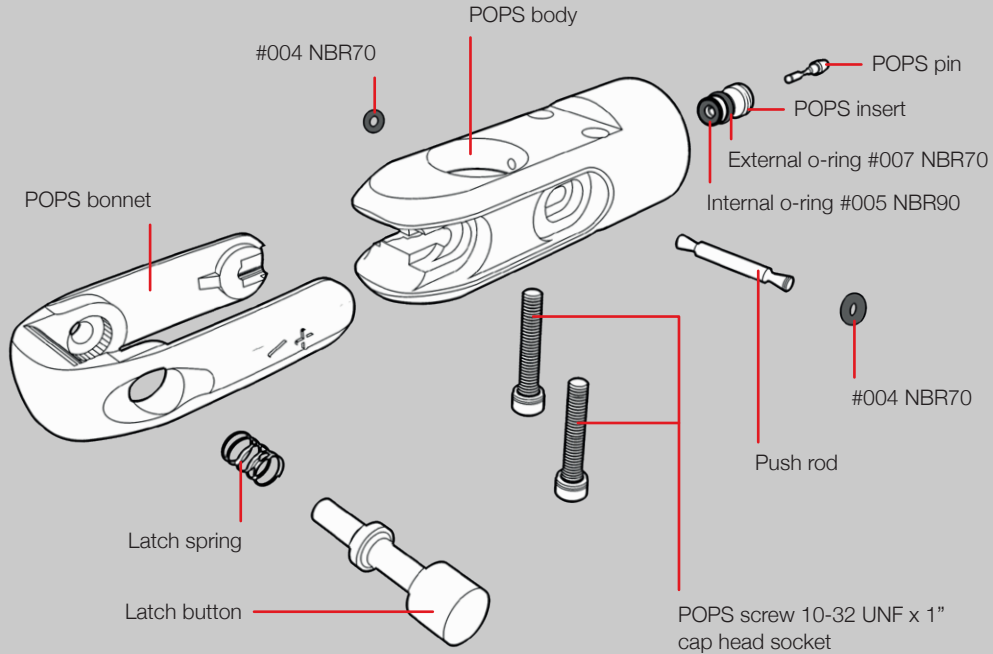

FIG-1

- 1 Magazine well
- 2 Safety button
- 3 Three-way body pin with 3x1 NBR70 o-ring
- 4 Magazine latch pivot pin
- 5 Magazine release catch
- 6 Magazine latch spring
- 7 MG 100 frame
- 8 POPS ASA retaining nuts
- 9 POPS ASA screws 10-32 UNF x 1" cap head socket
- 10 Trigger
- 11 Trigger spring
- 12 Trigger plate
- 13 Trigger plate retaining screws
- 14 Three-way assembly
- 15 Three-way push pin
- 16 Trigger pin
- 17 Push pin retainer with 3x1 NBR70 o-ring

FIG-1

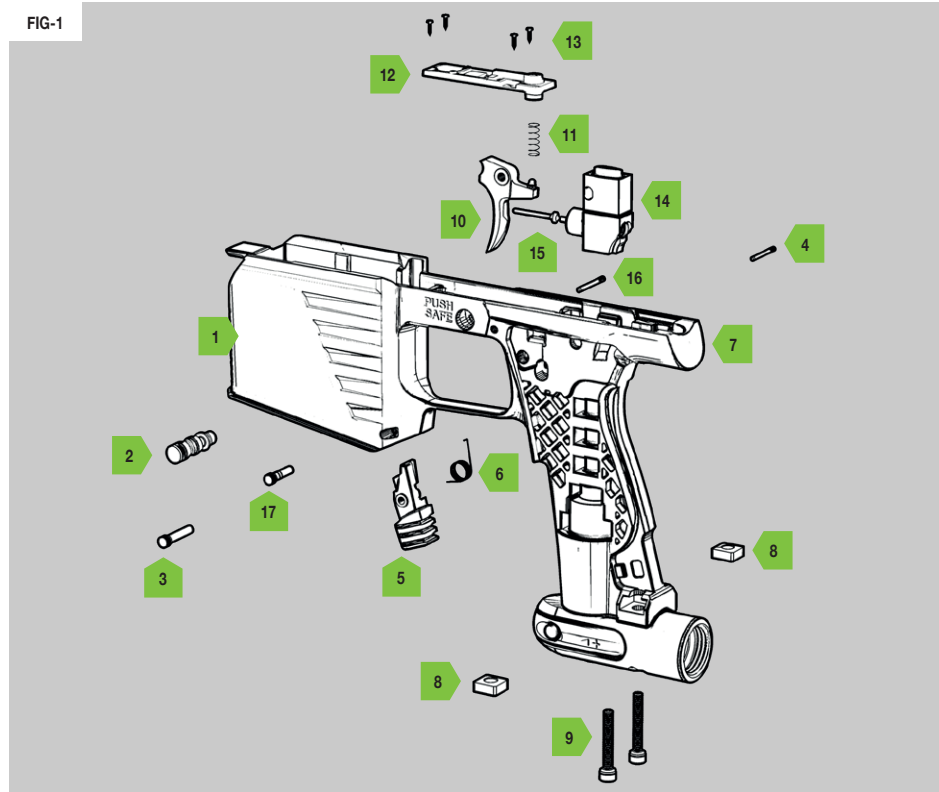
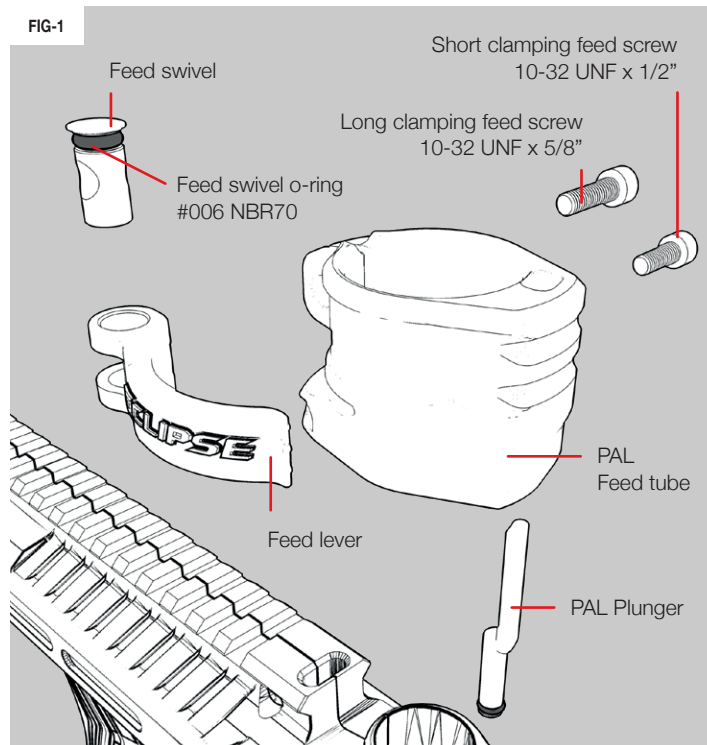

FIG-1

The MG 100 PAL clamping feedneck incorporates our Deftek system (patent pending), meaning the feedneck is designed to be slightly offset to neutralise any paintball bounce-back, providing the optimum paintball feed system.



42 TECHNICAL TWO-PIECE GRIPS

The MG 100's toolless two-piece grip system makes it incredibly easy to remove and clean the grips after a big day out in the field.

FIG-1

- A** Locate and pull back the rear grip locking tab.
- B** Use the finger recess to help release the rear grip section.
- C** Once released, fully remove the rear grip section from the frame.
- D** The front grip section can now be released and removed.
- E** You can now easily access the frame and separate grip pieces for thorough cleaning.

Repeat the steps in reverse order to reattach the grips to the frame.

- 1** **BE CAREFUL** when cleaning the frame, there are exposed operational elements that may be affected if wet.

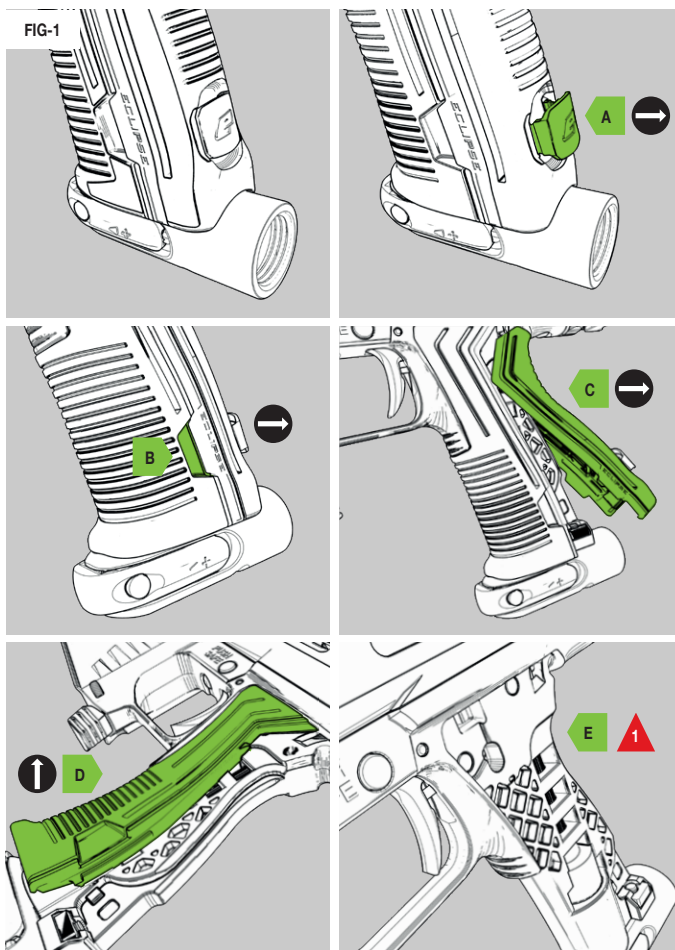
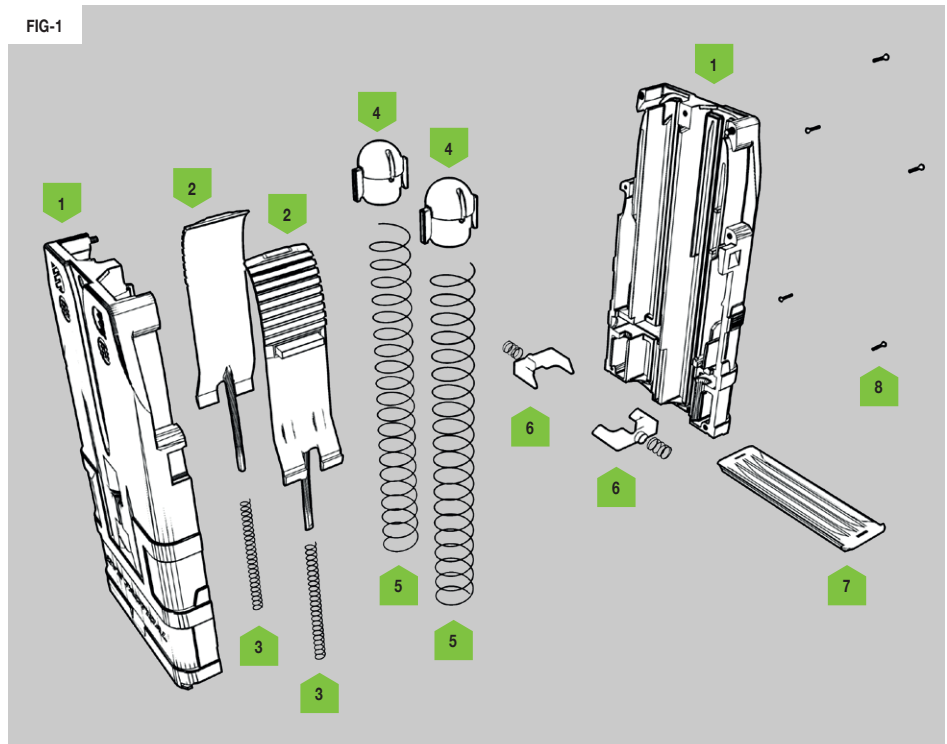

FIG-1

- 1 Magazine shells
- 2 Magazine chamber covers
- 3 Magazine chamber cover springs
- 4 Followers
- 5 Follower springs
- 6 Follower retention clips
- 7 Spring retention plate
- 8 Magazine screws

FIG-1



**SUPPORT**

As an Eclipse customer you will have access to our worldwide technical support network that will help you with any technical problems from localised service centres to on-site* tech support.

**WARRANTY**

Our exceptional 12 month* manufacturer's warranty backed by our online warranty system offers peace of mind and ensures your claim will be repaired or replaced in a snap!

**QUALITY**

All Eclipse products undergo meticulous checks by experienced specialists who care about the product that arrives at your door. Stringent quality control and the use of precision materials equals a quality product.

**STANDARD**

Your Eclipse marker is awesome and requires no after market parts, however, for genuine Eclipse accessories that compliment your playing preference or individual style consult your local Eclipse Dealer for upgrade options.

For more information about our Planet Eclipse Approved Tech Centres, visit our servicing page online:

PLANETECLIPSE.COM/SITE/SERVICE-CENTRES

* Conditions apply, see online policies for full details at planeteclipse.com

A

Accessories: **21,44**
Air system: **07,09,10,11,27,29,33,47**
ASTM standard: **02**

B

Barrel: **02,07,09,10,11,20,24,25,27,29,30,32,33**
Blanking plug: **23**
Bolt assembly: **38**

C

Chamber cover: **16,17,43**
Compressed air: **03,07,09**

D

Deftek: **41**
Detents: **25,32,33**
Dummy magazine: **09,13,29**

F

Fault finding: **32,33**
Feedneck: **09,12,13,18,19,29,41**
Feedtube: **07,12,35**
Feedtube plug: **07,12,13**
FIRE: **07,09,10,11,27,29**
Followers: **17**
Frame: **10,11,35,40,42**

G

Grip: **42**

H

Hopper fed: **09,12,13,28,29**

M

Magazine: **02,04,07,09,12,13,14,15,16,17,27,29,32,43**
Magazine chamber: **16,17**
Magazine latch: **09,13,14,15,27,29**
Magazine well: **02,07,09,13,14,15,27,29**
Magfed: **07,12,13,26,27**
Maintenance: **02,04,31,32**

P

PAL: **04,09,12,13,18,19,41**
Picatinny rail: **21**
Plunger: **04,13,18,19**
POPS: **07,09,27,29,33,39,40**

R

Register: **46**
Regulator: **02,03,04,07,09,32,33,36,47**

S

SAFE: **02,07,09,10,11,14,15,18,27,29,30**
Safety button: **04,07,09,10,11,27,29,30**
Shaped rounds: **03,15,16,24**
Shroud: **04,20,21**
Sling mounts: **23**
Spring retention plate: **17**
Springs: **04,17,30,43**
Stock: **04,22,23**

T

Three-way: **37**
Transportation: **02,04,30**

U

Unloading: **26,27,28,29**

V

Velocity: **03,24,32,33**

W

Warnings: **02,03,07,09,10,11,12,13,14,15,16,17,18,20,21,22,23,24,27,29,30,45**
Warranty: **44,45,46**

Y

Youtube: **31**



YOUR WARRANTY REGISTRATION CARD.

Planet Eclipse offers a 12 month limited warranty period* on the Eclipse® paintball marker. The Eclipse® paintball marker is warranted to be free from all manufacturing and production defects for a period of 12 months from the time of original purchase**. Warranty cover is dependent on successful completion, and receipt by Planet Eclipse Limited, of warranty registration and proof of purchase, either in electronic form at www.planeteclipse.com or vial mail using the warranty card included in every Eclipse® paintball marker manual. Warranty exemptions include, but are not limited to, accidental damage, wear and tear, unreasonable force, surface finish and perishable components such as o-rings, valves, screws, solenoids and break beam sensor units (at our discretion). By completing and returning this warranty card you agree to our privacy policy***.

I verify that I am at least 18 years of age and I have read the manual supplied with my Eclipse® paintball marker and I understand the safety cautions and warnings that it contains. Contact your dealer or Planet Eclipse Limited directly if you need a replacement set of instructions.

Full name:	Price (e.g. \$500.00):
Address:	Colour:
	Where did you hear about your Eclipse marker?
	Magazines <input type="checkbox"/> Internet <input type="checkbox"/> Friends <input type="checkbox"/>
	Other (please specify):
City:	Why buy Eclipse?
Postal/Zip Code:	WRITE SERIAL NUMBER HERE <input type="text"/>
State:	
Country:	
Contact No:	
Email:	
Date of purchase (DD/MM/YY):	
Purchased from:	

Please complete and return this form with proof of purchase, within 14 days so that we may validate your 12 month limited warranty on your Eclipse® manufactured product. Please return to the address on the reverse of this form.

* For full terms and conditions that apply to the limited warranty visit www.planeteclipse.com

** Limited warranty is valid for 12 months from the proof of purchase date, or 12 months from the date of manufacture if no proof of purchase is provided.

*** Full details of the Planet Eclipse privacy policy can be found at www.planeteclipse.com



GET MORE - PLANETECLIPSE.COM

LICK.
STICK.
SEND.

PLANET ECLIPSE
130 FRANKLIN STREET
BUILDING L4 & L5
WARREN
RHODE ISLAND
02885
U.S.A.

TO BENEFIT FROM OUR INDUSTRY-LEADING
GLOBAL TECH SUPPORT PLEASE REGISTER
YOUR MARKER ONLINE TODAY

WARRANTY.PLANETECLIPSE.COM



—



GET MORE
PLANETECLIPSE.COM

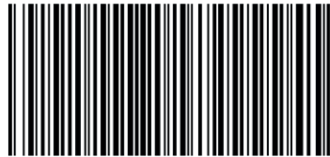

802.072.A-000

THIS PRODUCT IS COVERED BY AND/OR LICENSED UNDER ONE OR MORE OF THE FOLLOWING PATENTS:

G.B. PATENTS:

2,342,710; 2,345,953; 2,352,022; 2,391,292; 2,391,063;

U.S. PATENTS:

7,836,873; 7,603,995; 7,073,284; 8,104,463; 7,509,953; 7,921,839; 7,089,697; 7,866,307; 8,082,912; 7,076,906; 7,607,424; 7,980,238; 8,960,175; 8,528,877; 8,201,547; 8,397,706; 8,210,160; 7,073,284; 6,311,682; 6,748,938; 6,860,259; 6,941,693; 6,973,748; 5,881,707; 5,967,133; 6,035,843; 6,474,326; 6,637,421; 6,644,295; 6,810,871; 6,901,923; 7,121,272; 7,100,593; 7,610,908; 7,603,997; 7,946,285; 6,349,711; 7,044,119; 7,185,646; 7,461,646; 7,556,032; 7,591,262; 7,617,819; 7,617,820; 7,640,925; 7,640,926; 7,866,308;

APPLICATION NUMBERS:

12/256,832; 12/613,958; 12/493,777; 11/654,721; 11/747,107; 12/503,504; 11/781,821; 60/832,548; 11/965,886; 10/280,115

Additional U.S. and International Patents may be pending.

USA

130 Franklin Street
Building L4 & L5
Warren, RI, 02885, USA
Call: +1 401 247 9061
planeteclipse.com/contact

UK

Unit 14 Premier Park, Acheson Way
Trafford Park Road, Trafford Park
Manchester, M17 1GA, England
Call: +44(0) 161 872 5572
planeteclipse.com/contact

EUROPE

Pe-Paintball.De Gmbh
Langenberger Str. 9 Tor 5 & 6
Düsseldorf 40233, Germany
Call +49 (0) 211 210 230-0
planeteclipse.com/contact

© Planet Eclipse Ltd.

2269_EN_PE_MG100-Manual-v1