



PLANET ECLIPSE: EMEK FL 3-WAY VALVE

USER MANUAL: ENGLISH

+ECLIPSE
PERFORMANCE PARTS



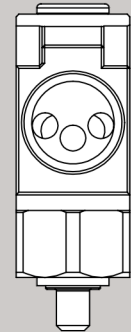
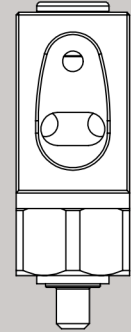
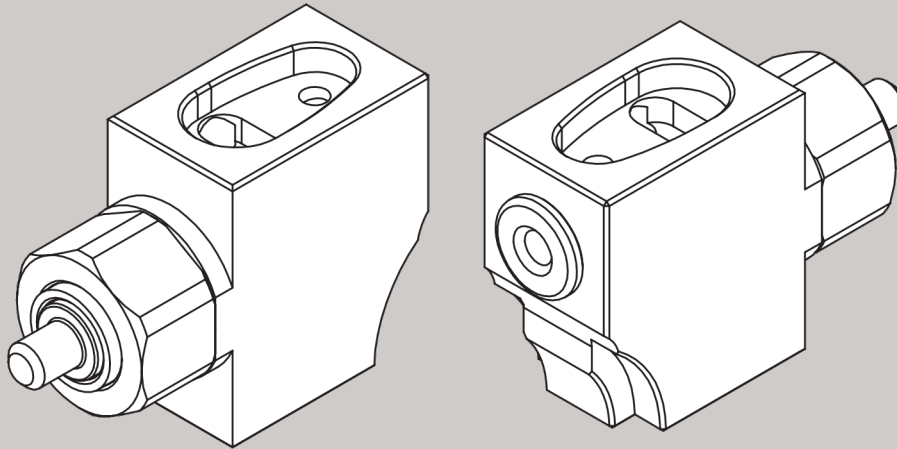





















EMEK
ETHA 2
EMF100





WARNING

BE SAFE. BE SMART. PLEASE READ CAREFULLY BEFORE USE.

-  **PLANET ECLIPSE PAINTBALL EQUIPMENT IS NOT A TOY. PAINTBALL SAFETY RULES MUST BE FOLLOWED AT ALL TIMES.**
-  Careless or improper use of the marker and/or parts, including failure to follow instructions and warnings within this User Manual could cause serious injury or even death.
-  Do not remove or deface any warnings attached to the marker.
-  Paintball industry standard eye/face/ear and head protection designed specifically to stop paintballs and meeting ASTM standard F1776 (USA) or CE standard (Europe) must be worn by the user and any person within range. Proper protection must be worn during assembly, cleaning and maintenance.
-  Hearing protection should be worn.
-  Never shoot at a person who is not wearing proper protection.
-  Never look directly into the barrel of the marker. Accidental discharge into the eyes may cause permanent injury or even death. Never look into the barrel or breech area of the marker whilst the marker is switched on and able to fire.
-  Keep the marker switched off until ready to shoot.
-  Treat every marker as if it is loaded and ready to fire.
-  The electronic On/Off button or mechanical Safety switch is the marker's disabling device. Always switch the marker off when not in use.
-  Always fit a barrel-blocking device to the marker when not in use.
-  Always remove paintballs from the marker when not in use.
-  Do not field strip or remove any parts while the marker is pressurised.
-  Do not pressurise the marker without all the components of the marker correctly installed, as high-pressure gas may be emitted.
-  Do not fire the marker without the bolt correctly installed.
-  Never put your finger or any foreign objects into the paintball feed tube of the marker.
-  Never allow pressurised gas to come into contact with any part of your body.
-  Always remove the first stage regulator and relieve all residual gas pressure from the marker before disassembly.
-  Always remove the first stage regulator and relieve all residual gas pressure from the marker for transport and storage.
-  Always follow guidelines given with your first stage regulator for safe transportation and storage.
-  Always store the marker in a secure place.
-  Observe all local and national laws, regulations and guidelines.
-  Persons under 18 years of age must have adult supervision when using or handling the marker.
-  Only use professional paintball fields where codes of safety are strictly enforced.
-  Use compressed air/nitrogen only. Do not use any other compressed gas or pressurised liquid including CO2.



WARNING

BE SAFE. BE SMART. PLEASE READ CAREFULLY BEFORE USE.



- ⚠ Always follow instructions, warnings and guidelines given with any first stage regulator you use with the marker.
- ⚠ Use 0.68 inch calibre paintballs only.
- ⚠ Always measure your marker's velocity before playing paintball, using a suitable chronograph.
- ⚠ Never shoot at velocities in excess of 300 feet (91.44 metres) per second, or at velocities greater than local or national laws allow.
- ⚠ Any installations, modifications or repairs should be carried out by a qualified individual at a licensed and insured paintball facility.



This User Manual is in English.

It contains important safety guidelines and instructions. Should you be unsure at any stage, or unable to understand the contents of this manual you must seek expert advice.



Le mode d'emploi est en Anglais.

Il contient des instructions et mesures de sécurité importantes. En cas de doute, ou s'il vous est impossible de comprendre le contenu du monde d'emploi, demandez conseil à un expert.



Este manual de usuarios (operarios)

Usuarios está en Inglés. Contiene importantes normas de seguridad e instrucciones. Si no está seguro de algún punto o no entiende los contenidos de este manual debe consultar con un experto.



Diese Bedienungs- und Benutzeranleitung ist in Englisch.

Sie enthaelt wichtige Sicherheitsrichtlinien und -bestimmungen. Sollten Sie sich in irgendeiner Weise unsicher sein, oder den Inhalte dies Heftes nicht verstehen, lassen Sie sich bitte von einen Experten beraten.

WARNING !

THIS USER MANUAL MUST ACCOMPANY THE PRODUCT IN THE EVENT OF RESALE OR NEW OWNERSHIP. SHOULD YOU BE UNSURE AT ANY STAGE YOU MUST SEEK EXPERT ADVICE.

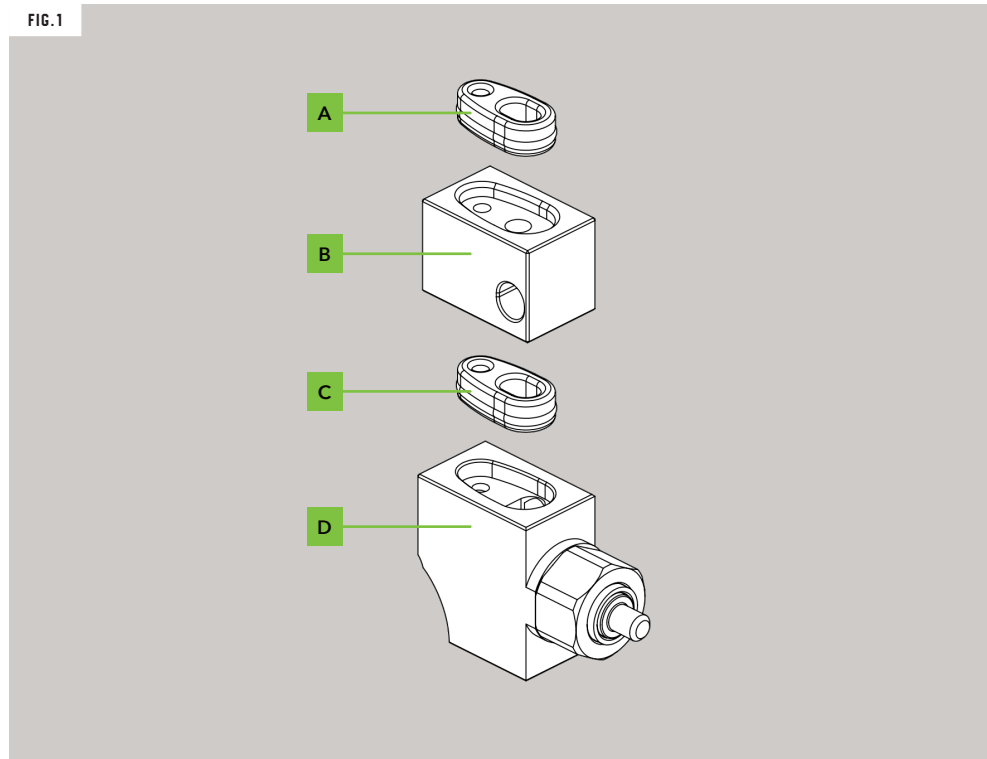

Fig.1

FL 3-Way Valve and Transfer Block
assembly.

- A** Transfer Block Gasket
- B** Transfer Block
- C** FL 3-Way Body Gasket
- D** FL 3-Way Valve

FIG.1



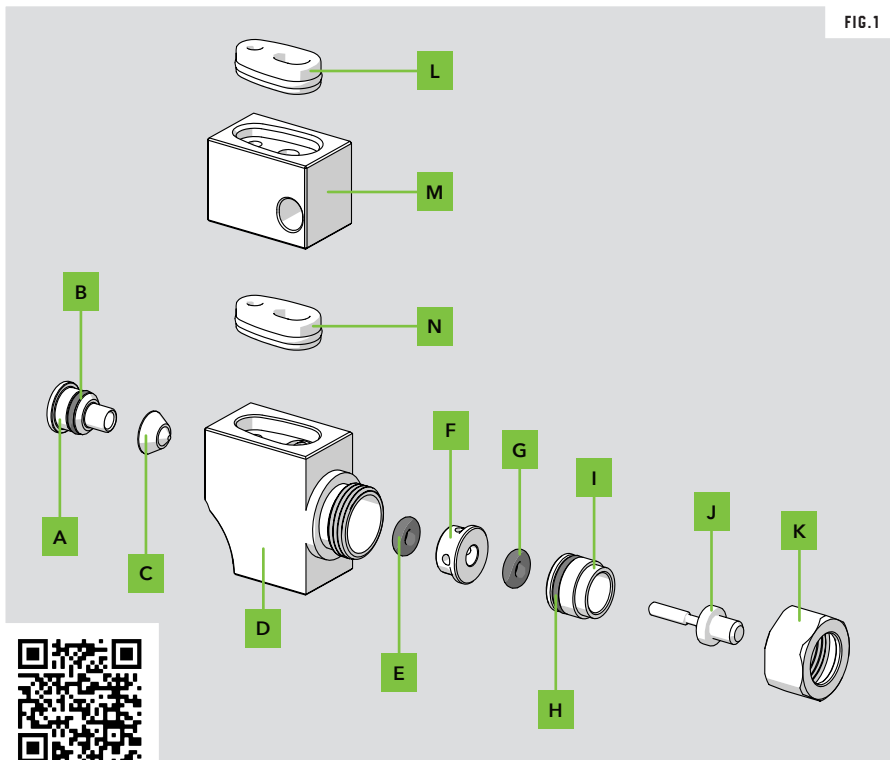

FIG.1

FIG.1

- A** QE Cap
- B** 4x1 NBR70 O-Ring
- C** QE Diaphragm
- D** FL 3-Way Body
- E** #004 NBR70 O-Ring
- F** FL 3-Way Spacer
- G** #004 NBR70 O-Ring
- H** 6x1 NBR70 O-Ring
- I** FL 3-Way Spool Guide
- J** FL 3-Way Spool
- K** FL 3-Way Cap
- L** Transfer Block Gasket
- M** Transfer Block
- N** FL 3-Way Body Gasket

 PlanetEclipseTV



SCAN FOR VIDEOS



GET MORE PLANETECLIPSE.COM



GET MORE

SCAN TO ACCESS
EVERYTHING THAT
IS PLANET ECLIPSE.



LEARN MORE

SCAN TO WATCH
IN-DEPTH TECHNICAL
GUIDANCE VIDEOS.

THIS PRODUCT IS COVERED BY AND/OR LICENSED UNDER ONE OR MORE OF THE FOLLOWING PATENTS:

G.B. PATENTS:

2,342,710; 2,345,953; 2,352,022; 2,391,292; 2,391,063;

U.S. PATENTS:

7,836,873; 7,603,995; 7,073,284; 8,104,463; 7,509,953; 7,921,839; 7,089,697; 7,866,307; 8,082,912; 7,076,906; 7,607,424; 7,980,238; 8,960,175; 8,528,877; 8,201,547; 8,397,706; 8,210,160; 7,073,284; 6,311,682; 6,748,938; 6,860,259; 6,941,693; 6,973,748; 5,881,707; 5,967,133; 6,035,843; 6,474,326; 6,637,421; 6,644,295; 6,810,871; 6,901,923; 7,121,272; 7,100,593; 7,610,908; 7,603,997; 7,946,285; 6,349,711; 7,044,119; 7,185,646; 7,461,646; 7,556,032; 7,591,262; 7,617,819; 7,617,820; 7,640,925; 7,640,926; 7,866,308;

APPLICATION NUMBERS:

12/256,832; 12/613,958; 12/493,777; 11/654,721; 11/747,107; 12/503,504; 11/781,821; 60/832,548; 11/965,886; 10/280,115

Additional U.S. and International Patents may be pending.

UK

Unit 14 Premier Park, Acheson Way
Trafford Park Road, Trafford Park
Manchester, M17 1GA, England
Call: +44(0) 161 872 5572
planeteclipse.com/contact

USA

130 Franklin Street
Building L4 & L5
Warren, RI, 02885, USA
Call: +1 401 247 9061
planeteclipse.com/contact

EUROPE

Pe-Paintball.De Gmbh
Langenberger Str. 9 Tor 5 & 6
Düsseldorf 40233, Germany
Call +49 (0) 211 210 230-0
planeteclipse.com/contact

© Planet Eclipse Ltd.
5011__EN_EM EK-FL-3Way-Manual