

# **TGR** PROJECT **ONE**

## **USER MANUAL**

# Specification

## Left Side

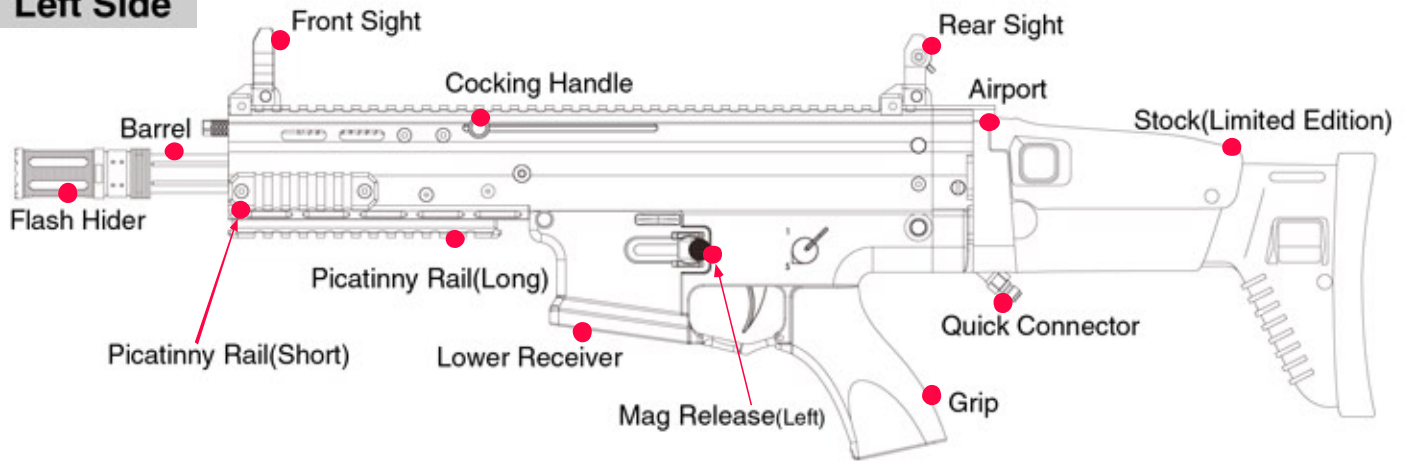

## Right Side

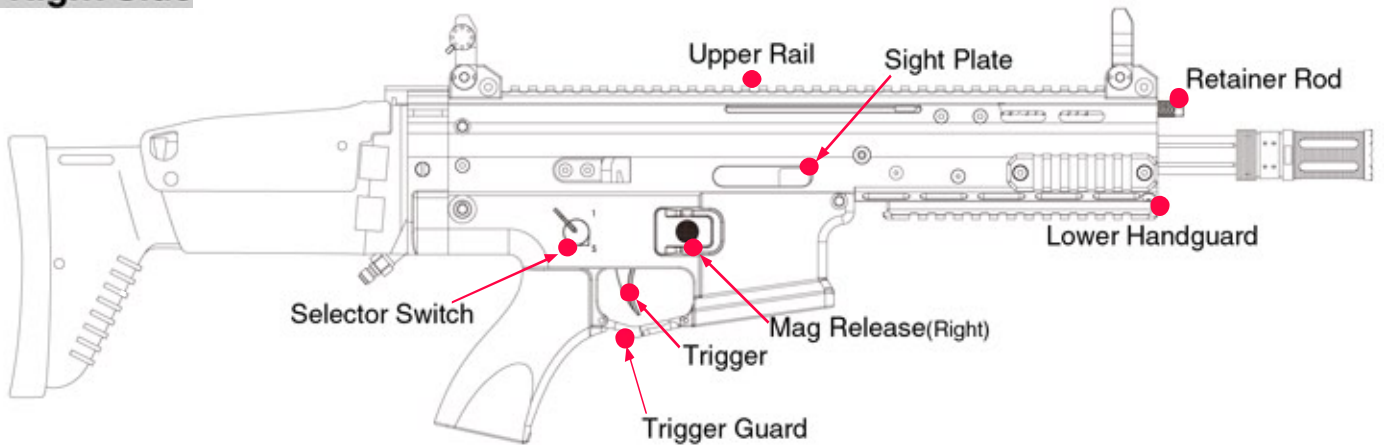

## Marker Model Specifications

<b>Model :</b>	HONORCORE TGR1
<b>Caliber :</b>	0.68(17mm) and Fin Stabilized Round Ready
<b>Action :</b>	Semi Automatic – open bolt Blowback
<b>Fire Selector :</b>	Ambidextrous
<b>Rail System :</b>	8" Quad RIS
<b>Magazine Release :</b>	Ambidextrous
<b>Propellant :</b>	HPA, CO <sub>2</sub> , Nitrogen
<b>Working Pressure :</b>	650PSI +
<b>Gas Efficiency :</b>	Semi Auto (2 seconds between trigger pulls) HPA Version 13ci = approx. 100
<b>Ball Feed :</b>	Spring loaded Magazine Fed

<b>Standard Barrel Length :</b>	9" (23cm)
<b>Barrel Type :</b>	Smooth Bore (0.69")
<b>Total Length :</b>	(Without Tank and stock) 55cm
<b>Effective Range :</b>	(Standard 0.68 Paintball – 3.2g) 45m/147ft (FS Round) 70m/230ft
<b>Weight :</b>	(Without Tank and stock) 1.95KG/4.3LB
<b>Muzzle Velocity :</b>	Upto 300 FPS

# TABLE OF CONTENTS

i. Warning	P.1
ii. User Safety precautions	P.1
iii. Operating Instructions	P. 2
iv. Disassembly	P.7
v. Cleaning and Maintenance	P.10
vi. Schematics	P.11
vii. Troubleshooting	P.13
viii. Warranty and Repair Policy	P.14
ix. Q&A	P.15

## 1. Warning Note



**WARNING:** This is not a toy. Misuse may cause serious injury or death. Eye protection designed specifically for paintball must be worn by the user and persons within range. Recommend 18 years or older to purchase. Persons under 18 must have adult supervision.  
**READ OWNER'S MANUAL BEFORE USING.**

**\*\*\*Please Do NOT tamper with or attempt to adjust wire Detents\*\*\***

## 2. User Safety Guidelines

- Treat Every Marker as if it was loaded.
- Never look down the barrel of a Marker.
- Keep your finger of the trigger until you are ready to shoot.
- Never point the marker at anyone or anything you do not intend to shoot.
- Do not insert the magazine in the gun and always make sure the chamber is clear. Until you are inside the field.
- Please ensure that the magazine is removed from the magwell at the end of each game and ensure that the chamber has been cleared.
- Always remove Projectiles and Propellant source, depressurize before disassembly.**

- h. After removing the propellant source and Projectiles insert the markers muzzle in a shooting bucket and dry fire the marker so that the bolt is lunged forward.
- i. Always store the Marker unloaded and depressurized in a secure place away from children.
- j. Transport Marker in HONORCORE ase or a fully enclosed bag.
- k. Follow warnings listed on propellant source for Handling and storage.
- l. Do not shoot at fragile objects like glass windows etc.
- m. Everyone within range MUST wear Eye, Face and Ear protection designed specifically to stop Paintballs.
- n. Chronograph the Marker before every activity ensuring that it is shooting at or below 300FPS.

## 3. Operating Instructions

### 1. Selector Switch Safety (First) /Fire

The HONORCORE TGR2 features ambidextrous controls including fire selector switch and Magazine release buttons.

Always ensure to keep the marker on safe mode until everyone is in full safety gear and you are ready to shoot.

Keep Finger off trigger till ready to shoot.

- ALWAYS KEEP SELECTOR SWITCH (SAFETY ON) SAFE MODE = UNLESS FIRING
- ALWAYS KEEP THE MAGAZINE OUTSIDE THE MAGWELL WHEN YOU ARE NOT INSIDE THE SHOOTING AREA.
- READ, FAMILIARIZE YOURSELF AND ANY OTHER USER OF THIS MARKER WITH THE SAFETY INSTRUCTIONS IN THIS MANUAL.
- FOLLOW THESE INSTRUCTIONS WHEN USING, WORKING ON, TRANSPORTING OR STORING THIS MARKER.
- DO NOT EXPOSE THE MARKER IN NON DESIGNATED PUBLIC PLACES AND ENSURE THE MARKER IS INCASED/PACKED INSIDE A CASE WHEN TRANSPORTING.

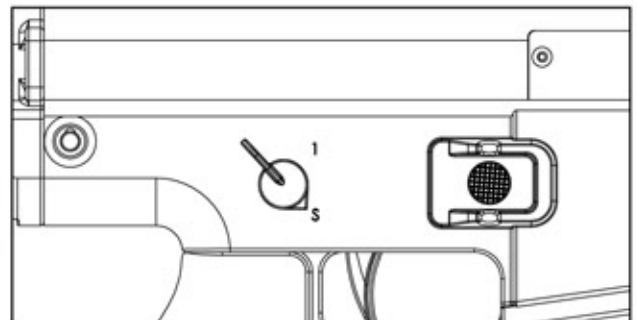

▲ ALWAYS KEEP SELECTOR SWITCH (SAFETY ON) SAFE MODE = UNLESS FIRING

## 2. Charging/Racking the Marker

HONORCORE TGR2 features a fully functional charging handle that is responsible for locking back the bolt in the ready position.

Always rack the Marker prior to loading the propellant.



## 3. Loading/unloading the propellant

HONORCORE TGR2 will accept different types of propellants (CO2, HPA) as long as the input pressure is 800psi.

Unless the specific marker model is designed for CO2 only, hence it will only accept CO2 and will not accept any other propellant.

Ensure you follow these safety instructions on propellant source accurately.

Only Load your marker with propellant immediately before use and depressurize immediately after use.

Do not store your marker loaded or pressurized.

### Loading with propellant (Pressurizing)

- a. Rack the marker by pulling the charging handle all the way back ensuring hammer is locked on trigger sear.
- b. Place the selector switch on SAFE.
- c. Fold stock guide/rod downwards
- d. Insert tank into airport inlet threading clockwise until secure
- e. Fold stock guide/rod back up
- f. Install stock by pulling down on the locking lever while sliding into guide and tank
- g. Point marker into shooting bucket or safe area switch selector to Fire mode and dry fire to ensure proper operation, place back on safety mode.



## Depressurizing the Marker

- a. Remove Magazine.
- b. Insert muzzle into shooting bucket and fire 3 times.
- c. Disconnect propellant source or in case of tank equipped with on/off switch turn off.
- d. Dry fire into shooting bucket until marker is completely depressed.
- e. Remove Stock.
- f. Fold guide downwards.
- g. Unthread tank counterclockwise.
- h. Clean Marker and store in HONORCORE Case.

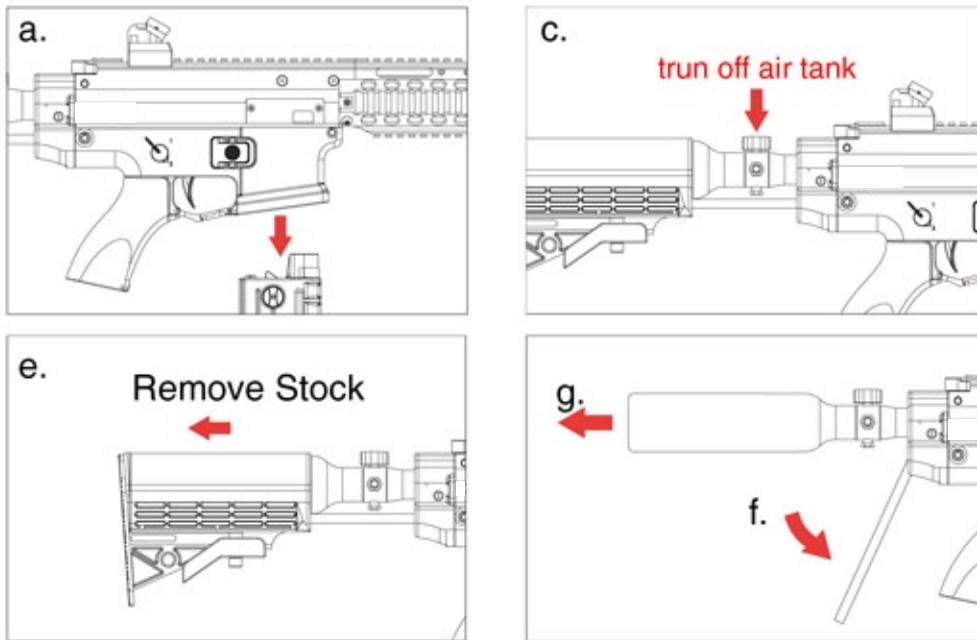

## 4. Loading/unloading the Magazine

- a. HONORCORE TGR2 comes with 2 magazines, MAG-12 and MAG-18 round spring-loaded magazines that are both fin stabilized round ready.
- b. HONORCORE TGR2 will accept a variety of 0.68 magazines available in the market today including box MAGS.
- c. HONORCORE TGR2 will shoot both standard 0.68 rounds and 0.68 fin stabilized projectiles.
- d. To load the magazine with projectiles simply wind the spring wheel in the clockwise direction until the follower is locked all the way up.
- e. Push down on the locking latch while inserting the rounds.

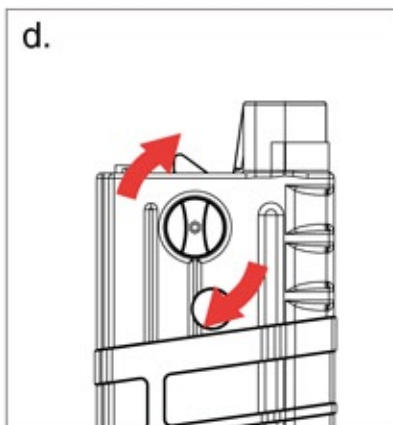

## ***To insert the magazine into the Marker.***

- a. Simply insert the magazine into the magazine well as shown below ensuring that it is securely locked on the magazine well latch.

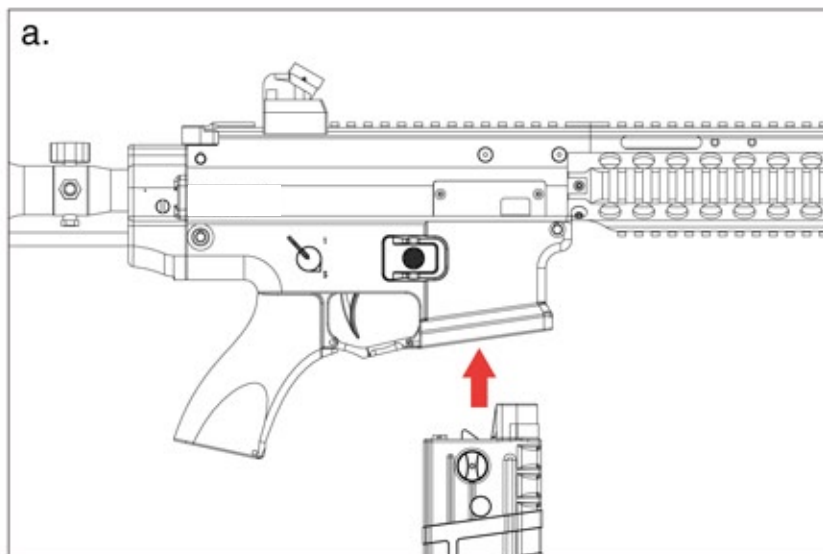

## ***To remove the Magazine***

- a. Hold magazine with non- trigger hand.
- b. Press on either left or right magazine release buttons.
- c. Simply pull magazine downwards to remove from magazine well.

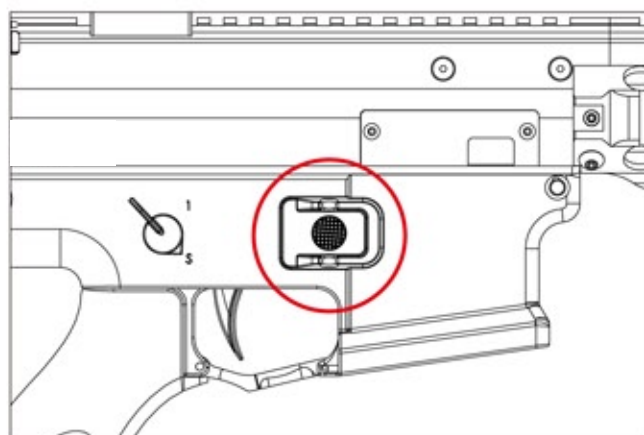
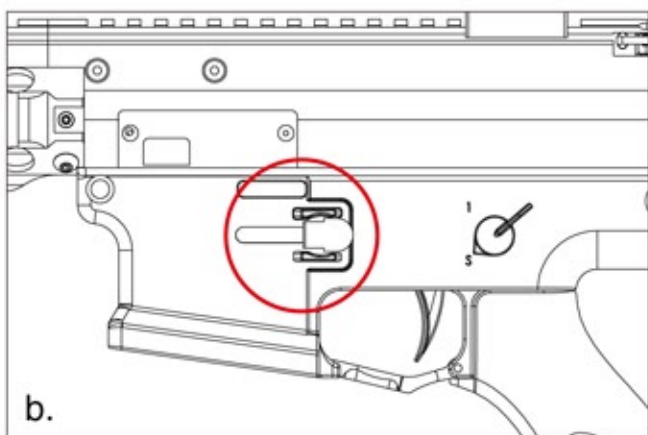

## BASIC Maintenance

- a. Please ensure the basic preventative maintenance is completed regularly.
- b. Basic internals (BOLT, HAMMER, GAS PORTS) should be removed after every 500-600 rounds for basic cleaning and lubing.
- c. Trigger assembly should be wiped clean and lube moving parts with organic silicon oil.
- d. Barrel should always be squeegeed clean to ensure better accuracy
- e. Magazines should be disassembled and cleaned when exposed to dust, mud or paint to ensure proper operation and effective feeding. Please ensure the correct reassembly based on the diagram.

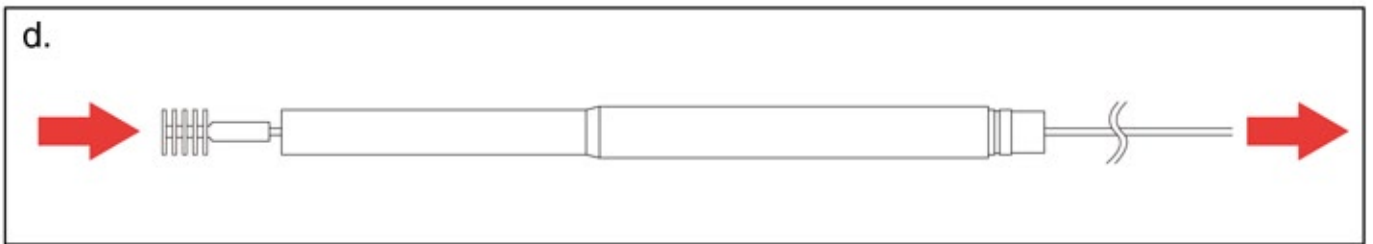
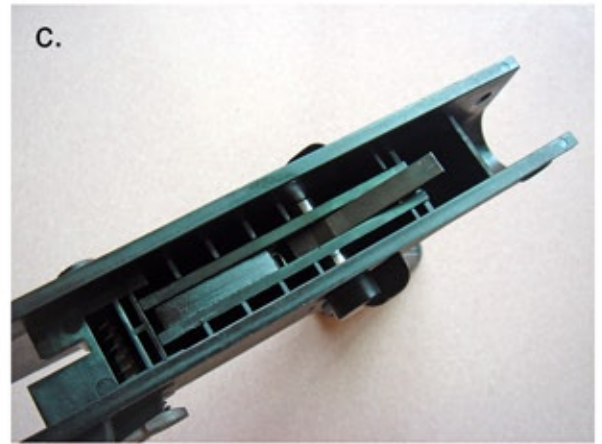
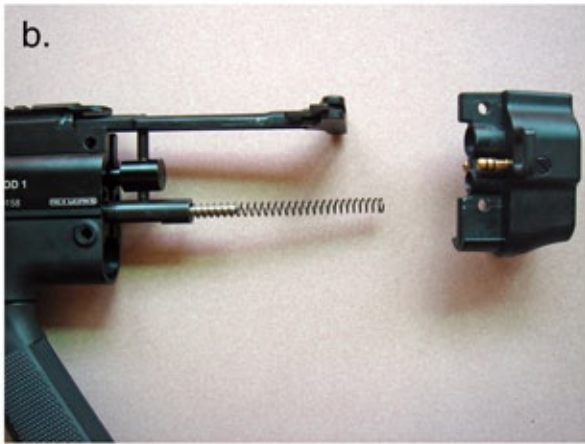

## Storage

- a. Before storage, unload and remove air supply. Place the marker selector switch on Safe Mode. (Always store your marker clean, lubricated, in a dry area and inside the HONORCORE case.)
- b. Store your marker with the bolt in the forward position. (Always store your magazines unloaded with the spring unwound (released).)  
(To forward the marker action, hold back the charging handle back  $\frac{3}{4}$  of the way, then pull the trigger and release the charging handle forward, slowly.)

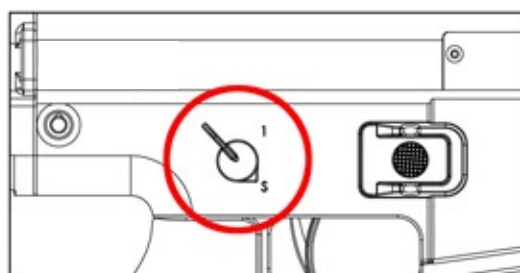
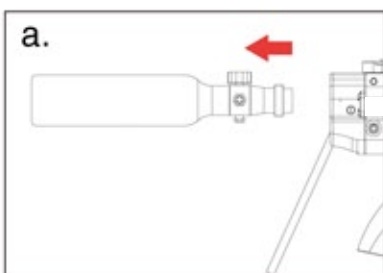



## 4 .Disassembly

**WARNING :** Always wear protective gloves when disassembling any marker to avoid scratches or cuts from any tools you are using or parts.

### 1. Removing the barrel

HONORCORE TGR2 features a true free floating barrel and rail system that means you can remove the barrel at anytime very quickly and easily for cleaning or replacement whether that be switching from CQB role to sniper or just replacing the muzzle hider with a mock silencer.

- With the marker's top facing upwards, simply twist the barrel counterclockwise until open.
- Use squeegee to clean properly.
- Place barrel back by threading into top receiver clockwise (Do not over tighten).

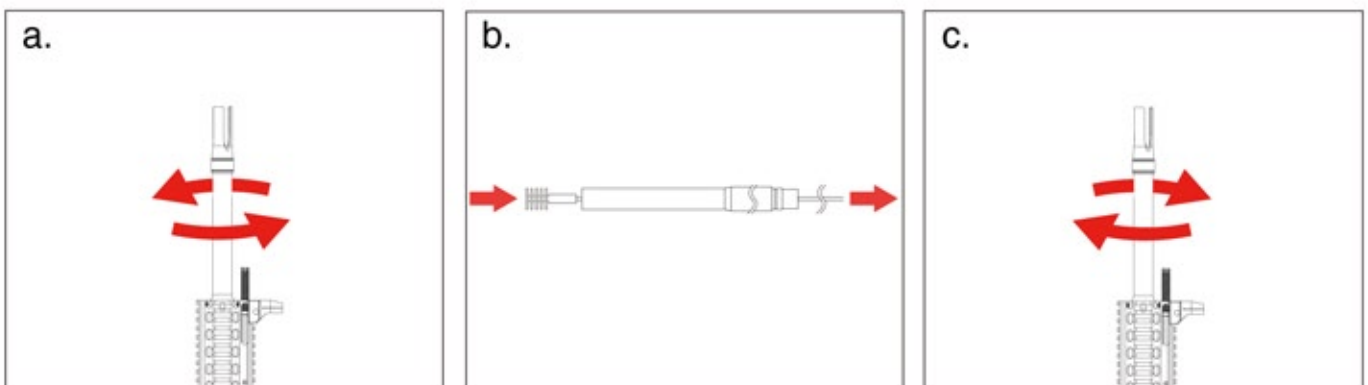

### 2. Removing the Lower receiver

Designed just like a real AR the HONORCORE TGR2 has a complete single piece lower receiver that can be completely disassembled by removing 2 set pins only.

- Remove both set pins as shown below.
- Slide the lower receiver off as shown.
- Note that the HONORCORE TGR2 will accept almost all GBB airsoft and real AR pistol grips.



### 3. Removing the RIS

HONORCORE TGR2 Features a true Free-floating RIS and barrel system.

- a. Unscrew Charging Handle rod counterclockwise.
- b. Pull guide rod and spring out.
- c. To remove RIS unscrew 5 setscrews around barrel nut area, pull out RIS, RIS mount and barrel Nut.

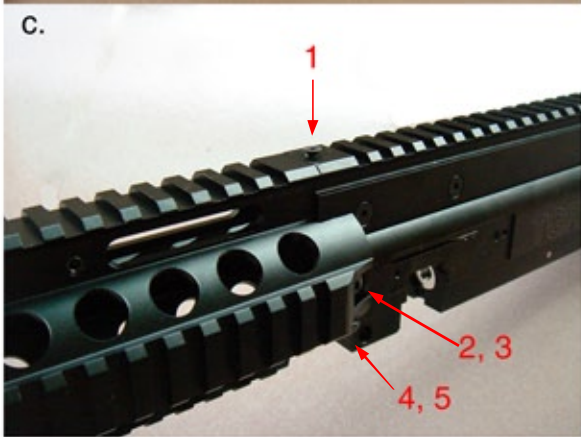

### 4. Removing the Airport

NOTE : Ensure Marker is uncharged / unracked ie bolt forward.

- a. After disassembling the lower receiver remove upper receiver pin as shown below.
- b. Pull airport out Gently to avoid pulling out internals as well (watch out for main spring.)



## 5. Removing the Internals (Bolt, Hammer and main spring)

Once you have disassembled the lower receiver and Airport

- a. Unlock charging handle and pull out with internals.



## 6. Removing Power Valve

- a. Once you have removed the RIS and RIS mount, use the charging handle rod as a tool to remove the chamber plug.
- b. Remove cup seal and spring.
- c. Inspect cup seal for dirt or damage clean or replace accordingly.
- d. Remove Valve locking screw part number and push forward with a non abrasive rod.
- e. Inspect O-rings replace if needed.

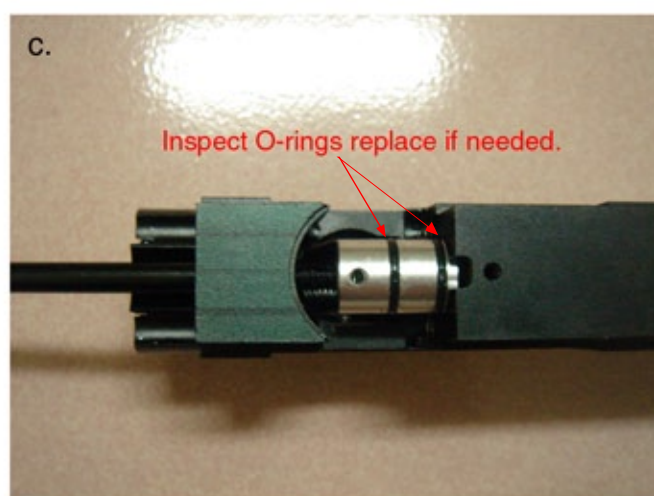
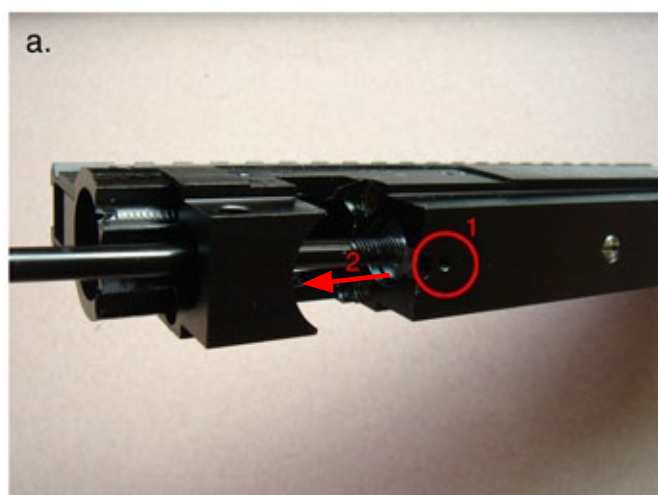

# 5 .Cleaning and Maintenance

## 1. Cleaning the barrel.

- a. Use a good quality double swab cleaning rod; ensure barrel is clean for better accuracy.

## 2. Cleaning the internals.

- a. Clean the inside of the upper receiver / core from any debris to ensure a consistent smooth Motion of all moving parts like the bolt and hammer.
- b. Clean the bolt and hammer along with the airport.
- c. Re lube all O-rings with high quality silicon grease or oil.
- d. Inspect all O-rings before reassembly.

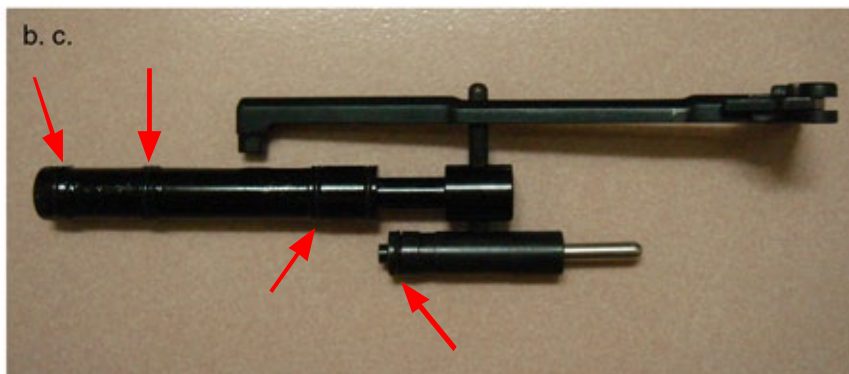

## 3. Cleaning the magazine

- a. Ensure the magazine is unloaded with a spring release.
- b. Remove floor plate.
- c. Unplug the two set screw covers
- d. Remove the two main screws holding to the receivers.
- e. Open up the magazine receivers
- f. Carefully pull out the round locking mechanism.
- g. Clean spool assembly and spring
- h. Clean the magazine thoroughly, removing any debris, dust and paint to ensure a smooth operation of the magazine.
- i. Reassemble through reverse assembly. (Check diagram for correct assembly)

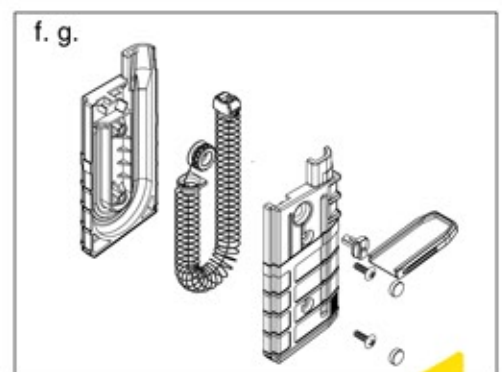
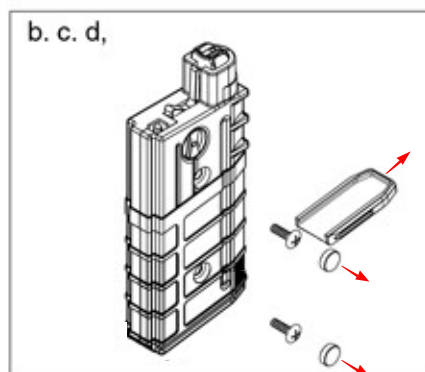
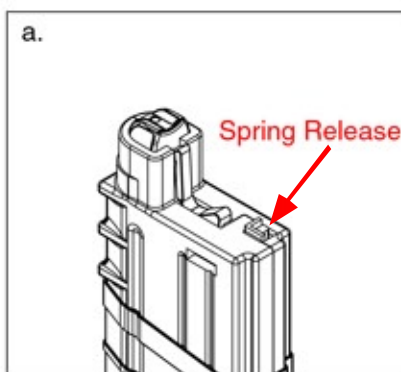

# 6. Schematics - TGR1 HPA Version

(Do not attempt to disassemble any parts while marker is loaded or and pressurized)

HONORCORE TGR1 MK 1 MOD 1 - Exploded Diagram

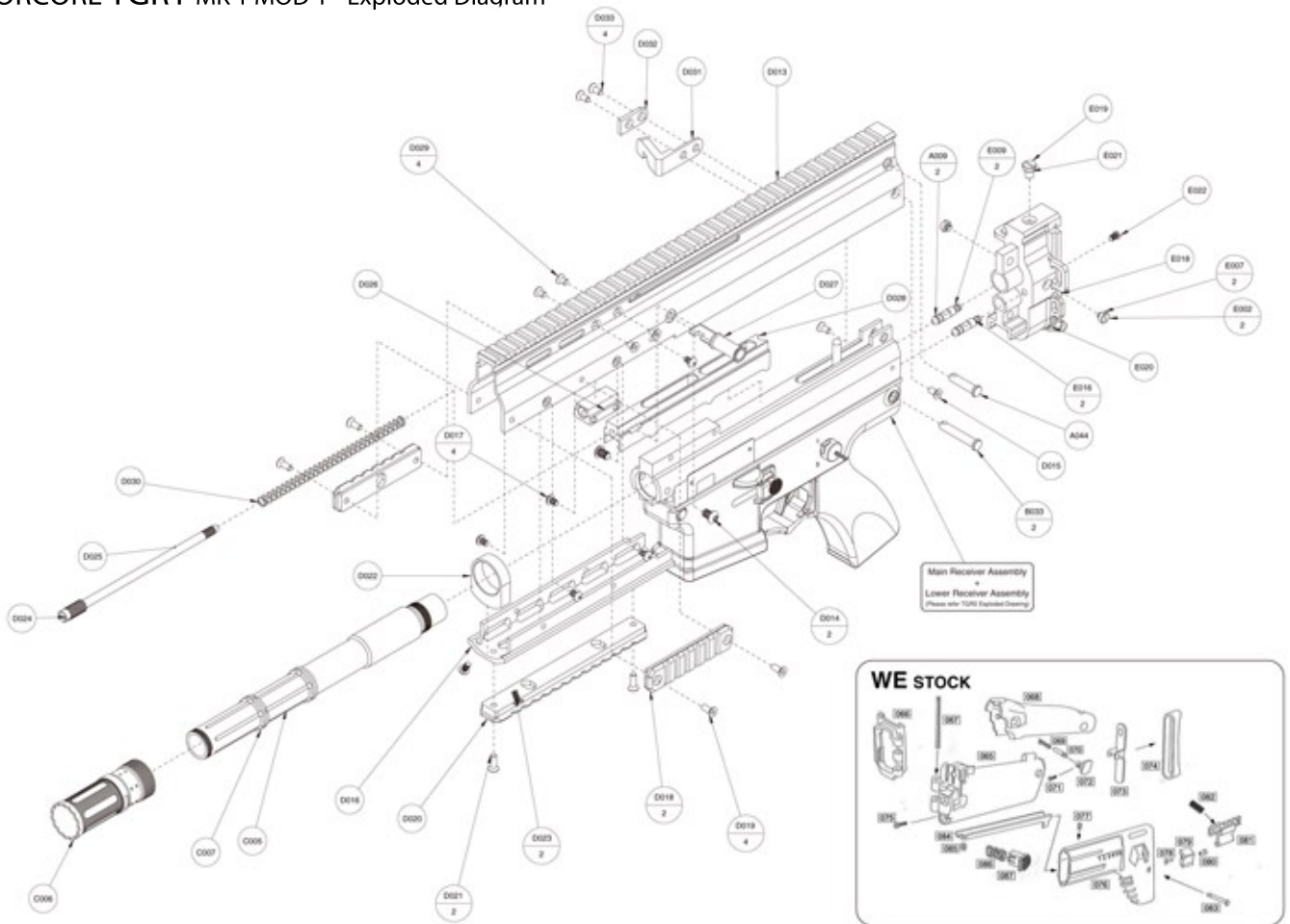

# 6. Schematics - TGR2 HPA Version

(Do not attempt to disassemble any parts while marker is loaded or and pressurized)

HONORCORE TGR2 MK 2 MOD 1 - Exploded Diagram

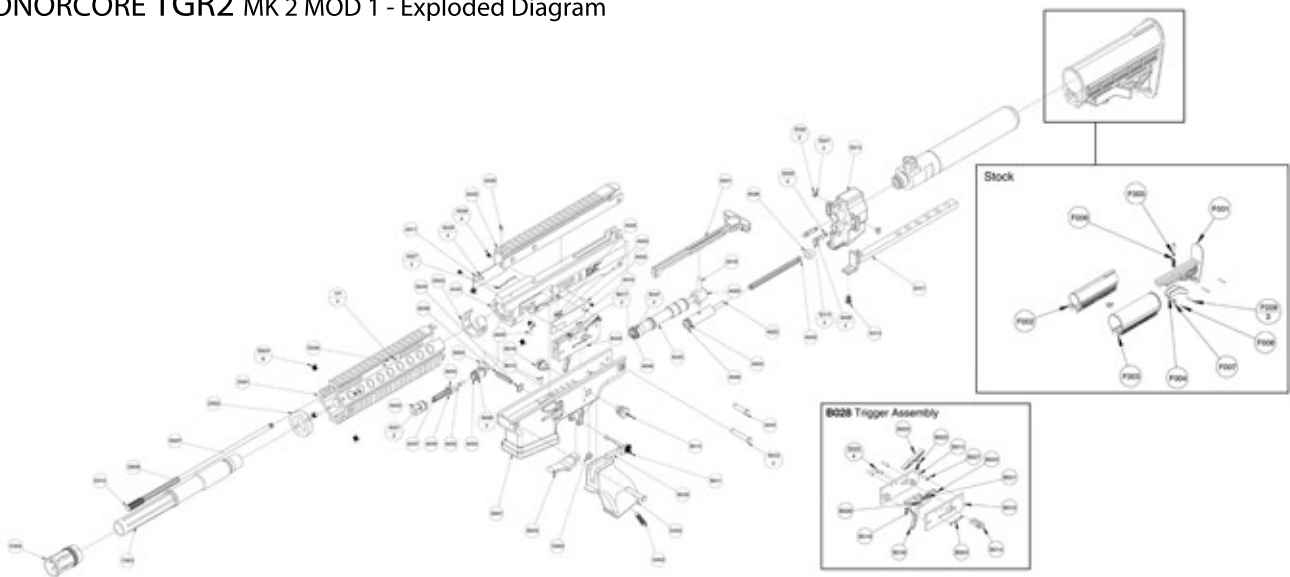

(Do not attempt to disassemble any parts while marker is loaded or and pressurized)

### Magazine 12rd

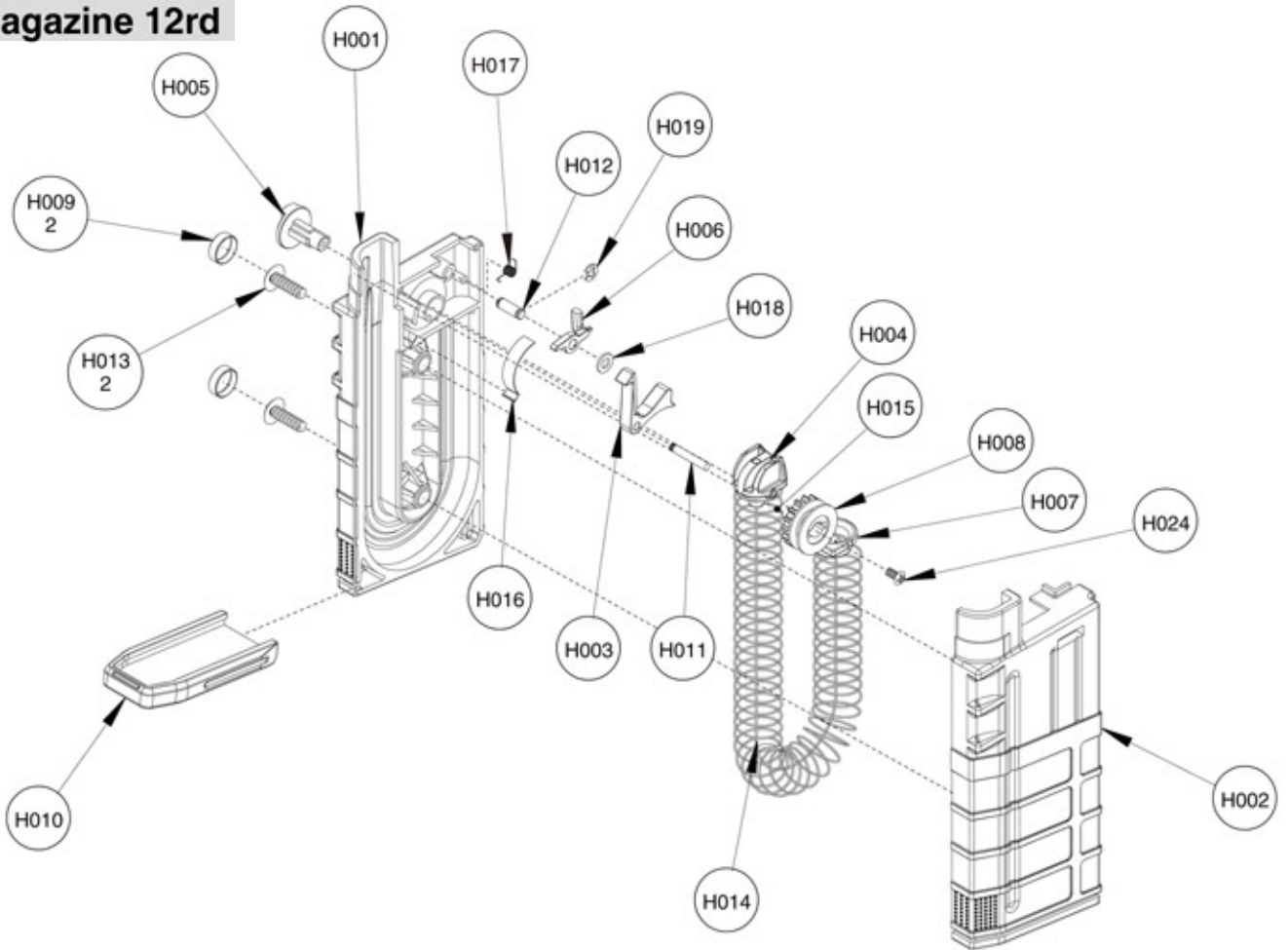

### Magazine 18rd

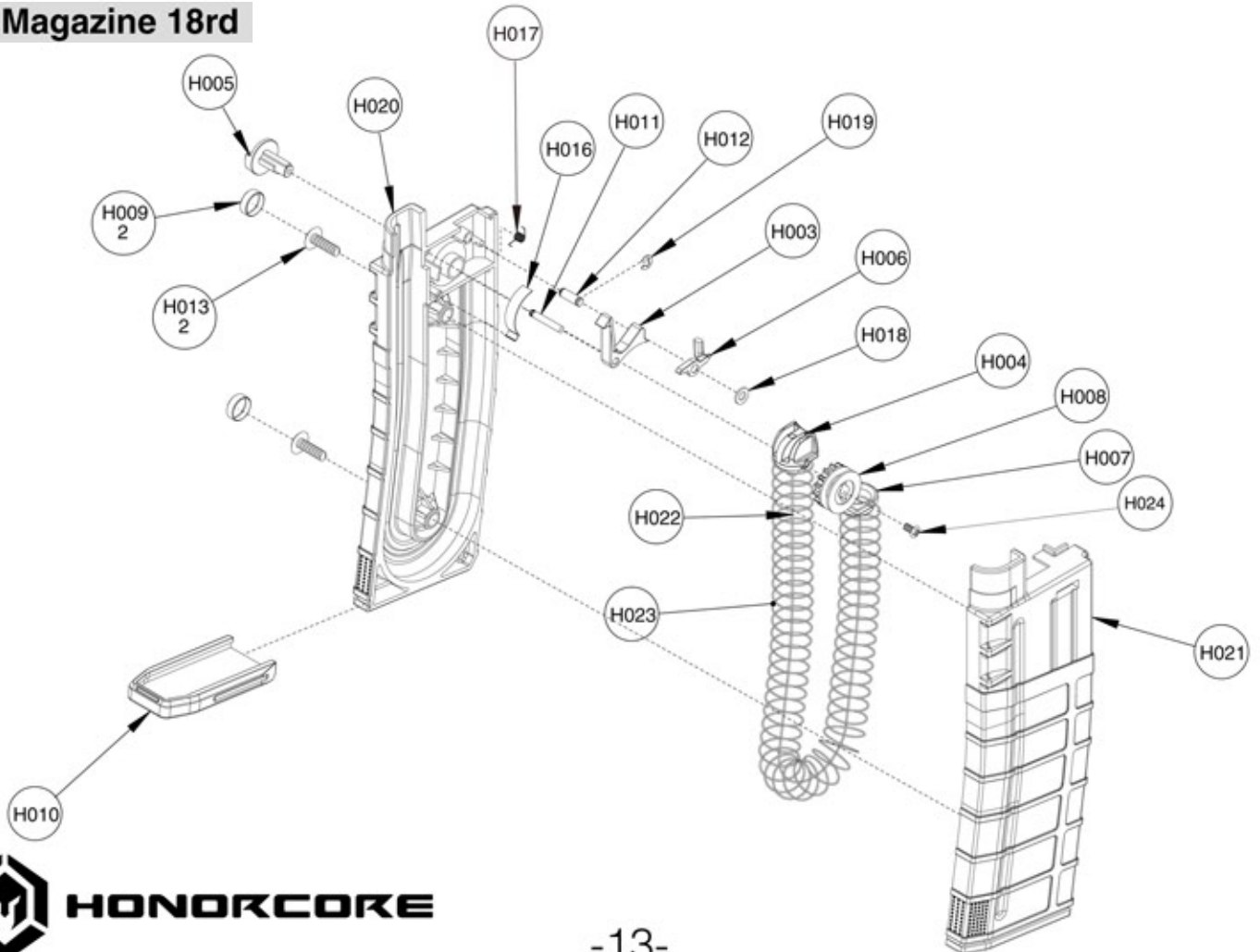

# 7. Troubleshooting

## TGR1, 2 series Trouble Shootings :

**Unusual burst shot (Burping) :** When set on SEMI, 2 or 3 burst shots take place

Solutions :

1. Piston O-ring broken : change new O-ring **A025**
2. Main bolt O-ring wrong size(too big) : change correct O-ring **A047**  
: lubricate to make main bolt operate smoothly
3. Check trigger group : sear spring pressure or spring size **B023**
4. If trigger group pin hole break : change new trigger group seat (plate) **B012, B013**
5. Valve rod **A052** of rod cover **A053** loosen : tighten up

**Leaking :** Check leaking point, change to correct size O-ring (please check diagram)

Solutions : Change to correct size O-ring (please check diagram)

**Ball break :** Meaning ball break in chamber or barrel

Solutions :

1. Check magazine main spring release button (main spring needs to be totally released)
2. Check ball stopper **A057** angle
3. Check broken ball pieces, dust....in chamber or barrel : clean chamber and barrel
4. Check Venturi rod **A046** (loosen) : tighten up
5. Check round compatibility and quality.

**Velocity :** HONORCORE TGR2 HPA series velocity is set at 250 to 270 ft/sec

Low : velocity lower than expect

Solutions :

1. Check main spring **A049** : wrong size or damage or loosen : change new one
2. Check main bolt **A045** : if bolt gas release hole up side down ( hole up ) : hole has to be down
3. Check main bolt **A045** and piston o-rings **A025** : if wrong size (too big or too small) :  
Use the correct size of the O-ring.
4. Check main valve **A054** setting screw **A055** : if loosen: tighten up
5. Check valve rod **A052** and rod cover **A053** : if loosen: tighten up



# 8. Warranty and Repair Policy

## Warranty and Repair Policy

HONORCORE Warranties to the original purchaser that this product is free from defects in material and workmanship under normal use for a period of 1 year from the original date of purchase by the original purchaser.

HONORCORE agrees to repair or replace (at it's discretion) any product within a reasonable period of time. This warranty does not cover O-rings, scratches, nicks, wear and tear of parts, or fading of parts or damage caused by dropping or hitting the product.

This warranty shall not apply if it is evident to HONORCORE that the defect or malfunction had been caused due to misuse.

This warranty only covers original factory parts. Any modifications or tampering with the original parts shall not be covered by this warranty. Any damage caused by weathering, water or fire shall not be covered by this warranty. Warranty work shall only be conducted by HONORCORE technicians or HONORCORE Authorized Technicians.

If products need repair please contact us through email on [tech@honorcore.com](mailto:tech@honorcore.com)

To register your product, please create an account by entering your personal/company information including the unique serial numbers marked on the product on [www.honorcore.com](http://www.honorcore.com)

### IMPORTANT Note :

1. The warranty does not cover the magazines.
2. If R1 Air block screw is removed, It has to void warranty.

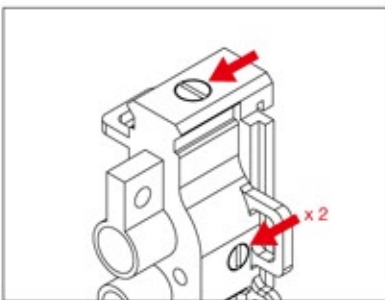

## 9. Q&A

### **Q1 : Is the HPA version of the TGR2 compatible with CO2?**

A1 : Yes, but since the differences between CO2 and HPA output pressure the end user needs to be careful about the spring you he/she chooses in order to fit the muzzle velocity you required.

### **Q2 : Paintballs jamming issues**

A2 : Make sure the paintballs are not overboard for our stock barrel. Our barrel is 17.5mm (0.688 inch) Don't use the paintball over the diameter 0.689", otherwise the paintball may explode in the chamber. ( moisture paintball may lost its shape, avoid to use them)

### **Q3 : Whole bottle leaking after installed**

A31 : Charging the handle before install the tank

A32 : Keep the Air pressure over 800 PSI, or whole bottle of HPA will be wasted. Have a shop check the output pressure of your tanks. Even if they are new they may not be over 800psi.

A33 : Field service to check that no O-rings are missing or bad. Replace with provided spare parts kit

A34 : Clean air chamber and use only approved lube. (light marker lube or Food grade silicone)

A35 : Cocking the charging handle again and dry fire right away.

A36 : Check if the main valve install reversely.

### **Q4 : Semi-auto fire become full-auto fire, then drain out whole canister.**

A41 : Your tank is empty and providing less then a steady 800psi output.

A42 : Your hammer and fire control group have proper installed.

A43 : Check any damage on the sear or hammer.

A44 : The spring under sear working properly.

A45 : Check the FCG, the last pin might over tied.

### **Q5 : FS round Jamming**

A51 : Because of molding point of FS rounds is usually not even, you may want you sand the molding point by hands to make it feeding smoothly.

A52 : Release the magazine screw ( lower one) about 1/4 clock.

A53 : View the How to Load FS rounds video on our YouTube site.

### **Q6 : Low Velocity**

A61 : Please check the paintball you using, oversize paintball may reduce the muzzle velocity.

A62 : Check if the main valve install reversely.

A63 : Make sure the tank output is over 800psi.

A64 : Make sure the marker is using the proper Scarab Arms O-ring.

A65 : Check for wear on any O-ring on a field service and replace with approved O-ring kit.

A66 : Make sure rear air block and charging rod are on tight.

### **Q7 : Safety switch lock**

A7 : Oil your Fire Control Group.