

DYE Precision, Inc.
USA 10637 Scripps Summit Ct. San Diego, CA 92131
P 858-536-5183 F 858-536-5191
EUROPE - UNITED KINGDOM Dye House, 7-8 Commerce Way
Croydon, Surrey, United Kingdom, CR0 4XA
P +44 (0) 20-8649-6330 F +44 (0) 20-8649-6339
GERMANY Albert Einstein Str. 2 B
77656 Offenburg, Germany
P +49 (0)781 639 349 91
ASIA No. 253, Guojhong Rd., Dali City
Taichung County 412, Taiwan (R.O.C.)
P +886 (0) 4-2407-9135 F +886 (0) 4-2407-2090
www.dyetactical.com

Copyright ©2012 DYE Precision, Inc. The stylized "DYE" logo, the "D" logo, DT logo and "DAM" logo are either registered trademarks, trademarks, or design trademarks of DYE Precision, Inc.

DYE Precision, Inc. U.S. Patent # 5,613,483; 7,594,503; 7,765,998. OTHER U.S. AND INT'L PATENTS PENDING.
Covered by one or more of the following U.S. Patents, 5,613,483; 5,881,707; 5,967,133; 6,035,843 and 6,474,326.
For a complete list of patents please visit: www.dyeprecision.com/patents



DYE ASSAULT MATRIX



DAM™ OWNER'S MANUAL

WWW.DYEPAINTBALL.COM



Included with your DYE ASSAULT MATRIX™

- DYE ASSAULT Matrix Marker
- 2 pc DYE Ultralite Barrel
- DYE Tactical Magazine
- Allen Wrench tool set including 0.05", 1/16", 5/64", 3/32", 1/8", 5/32", 3/16" and 1/4"
- 1/4 oz. DYE Slick Lube™
- ARK - Assault Repair Kit
- Barrel Sock
- Owner's Manual
- Warranty Card
- 9V Battery

The DAM™ comes with all the tools required to perform general maintenance and set up.

For a complete service the following tools are required:

- 5/16" Allen key
- #0 Phillips head screw driver
- A sharp pick to remove O-rings
- DYE Multi-Tool (sold separately)
- Retainer Clip Pliers

TABLE OF CONTENTS

- IMPORTANT SAFETY INSTRUCTIONS AND GUIDELINES	PAGE 02
- QUICK START UP GUIDE	PAGE 04
- AIR/NITROGEN.....	PAGE 07
- DAM™ BOARD SETTINGS AND FUNCTIONS	PAGE 08
- TRIGGER ADJUSTMENTS.....	PAGE 14
- BATTERY.....	PAGE 15
- DAM™ BOLT ASSEMBLY AND MAINTENANCE	PAGE 16
- DAM™ BOLT O-RING LIST	PAGE 19
- HYPER™ IN-LINE REGULATOR ADJUSTMENT AND MAINTENANCE	PAGE 20
- VELOCITY ADJUSTMENT	PAGE 20
- MAGAZINE OPERATION	PAGE 22
- ACCESSORY MOUNTING	PAGE 26
- LOADERS AND FEEDNECK	PAGE 28
- ANTI CHOP EYES AND BALL DETENTS.....	PAGE 29
- AIRPORT	PAGE 32
- TROUBLE SHOOTING	PAGE 33
- EXPLODED VIEW	PAGE 36
- WARRANTY AND LEGAL INFORMATION	PAGE 37



WWW.DYEPAINTBALL.COM

WWW.DYEPAINTBALL.COM



W A R N I N G

IMPORTANT SAFETY INSTRUCTIONS AND GUIDELINES

- The DAM™ marker is not a toy. Misuse may cause serious injury or death. Never point the DAM™ at anyone unaware of its function.
- Please read, understand and follow the directions in the DAM™ owner's manual.
- Eye protection that is designed specifically for paintball and meets ASTM/CE standards must be worn by user and persons within range.
- Recommend 18 years or older to purchase. Persons under 18 must have adult supervision.
- Always treat the DAM™ marker as if it were loaded and able to fire.
- Only use compressed air or nitrogen gas in the DAM™ marker. DO NOT USE CO₂
- Do not exceed 850 psi input pressure.
- Only use .68 caliber paintballs that meet ASTM/CE standards.
- Ensure all air lines and fittings are tightened and secured before gassing up the DAM™.
- Always chronograph the DAM™ marker before playing paintball.



W A R N I N G

IMPORTANT SAFETY INSTRUCTIONS AND GUIDELINES

- Never shoot the DAM™ marker at velocities in excess of 300 feet per second, or at velocities greater than local or national laws allow.
- Never look into the barrel or breech area of the DAM™ when the marker is switched on and able to fire.
- Compressed gas is dangerous. Do not allow compressed gas to contact your skin or try to stop a leak by covering it with your hand.
- Always fit a barrel-blocking device to your DAM™ when not in use on the field of play.
- The owner's manual and any related warnings or instructions should always accompany the product for reference or in the event of resale and new ownership.
- Do not point the DAM™ marker at anything that you do not intend to shoot.
- Do not shoot at people, animals, houses, cars or anything not related to the sport of paintball.
- Do not fire the DAM™ without the bolt screwed in completely.
- If you read these instructions and do not fully understand them or are unsure of your ability to make necessary adjustments properly, call DYE Precision or your local pro shop for help.

QUICK REFERENCE USING YOUR MARKER

QUICK START UP GUIDE

Before playing with your new DAM™ paintball marker there are a few important steps to take.

STEP 1. BATTERY INSTALLATION

A. Free either side of the tool-less grip by placing a finger in the groove located at the rear of the grip frame and pull away from the marker.

B. Open grip panel and install 9V battery on to the connector inside the frame. Note that the battery can only be connected one way.

WARNING: While closing the frame observe that no wires are caught between the frame and the grip panel. Improper assembly may cause permanent damage.

C. Close grip panel by first fully seating the left or right side of the grip. Then place the bottom edge into position (1) and tilt the top-front (2) into the frame. Then press the top-rear (3) until you hear a click.

STEP 2. BARREL INSTALLATION

A. Screw the barrel on to the front of the DAM™. Make sure it threads all the way in and that the barrel is secure.

B. Attach the barrel sock so that it covers the tip of the barrel and secure the strap around the back of the DAM™.



4

QUICK REFERENCE USING YOUR MARKER

STEP 3A. LOADER INSTALLATION

A. Install the DAM™ Feedneck by removing the button head screws (4) located on the right side of the gun on the Feedneck Cover Plate with a 1/16" Allen Wrench. Remove the cover plate and place the Feedneck Adaptor over the opening while ensuring the posts insert into the holes located at the top of the DAM™. Reinsert screws and screw until snug.

Do NOT over Tighten. A low-strength thread adhesive such as Loctite may be required to keep the screws in place.



B. With loader adaptor installed and the On-the-Fly Switch (5) in the rear position, use the lever arm to tighten your loader into the adjustable feedneck on the DAM™. For best performance use a force-feeding motorized loader, preferably the DYE Rotor™ Loader. Loader should now be held in with a snug fit. Also See Page 28 "Loaders and Feedneck"

STEP 3B. MAGAZINE INSTALLATION

A. With either the Feedneck Adaptor or the Feedneck Cover Plate installed, insert a magazine into the Receiver Well (6) located at the bottom-front of the marker. Press firmly until you hear a click. To release the magazine use the Release button (7), located in front of the trigger guard. Also see Page 22 "Magazine Operation"

5

QUICK REFERENCE USING YOUR MARKER

STEP 4. ATTACHING GAS SOURCE

A. Make sure that the knob on the left side of the ON/OFF Airport is in the OFF position by turning the knob clockwise or up. Now screw in your air system to the ON/OFF airport and turn the gas supply on by turning the knob of the airport counter clockwise all the way to the locked position. Also see Page 32 "Airport" and the following page "Air/Nitrogen"



WARNING: AFTER STEP 5, THE DAM™ WILL BE LIVE. BEFORE PROCEEDING, MAKE SURE THE BARREL SOCK IS IN PLACE AND DO NOT POINT THE DAM™ AT ANYTHING YOU DON'T INTEND TO SHOOT.

STEP 5. TURNING ON THE DAM™ AND CHECKING THE VELOCITY

- A. Make sure you and everybody around you is wearing ASTM/CE approved paintball masks.
- B. Press and hold the Power button, located on the control panel found on the left side of the marker body, until the DAM™ turns on. Also see Page 8 DAM™ Board
- C. Fill up the loader with .68 caliber paintballs. (For Magazine loading see Page 22 "Magazine Operation")
- D. Shoot the DAM™ over a chronograph to check the velocity. If adjustment is needed, adjust the velocity by turning the Hyper™ In-Line Regulator velocity screw:
- (i) Place a 3/16" Allen key through the rear bolt cap of the DAM™. Inwards (clockwise) will reduce the velocity and outwards (counter clockwise) will increase the velocity.
 - (ii) After each adjustment it will take a few shots before the change in velocity can be seen on the chronograph. Never adjust the DAM™ to shoot above 300fps or the maximum velocity permitted by field rules / local laws, whichever is lowest. Also see Page 20 "Velocity Adjustment"

AIR/NITROGEN

AIR / NITROGEN TANK OPTIONS AND INSTALLATION

The DAM™ will only work with Compressed air or Nitrogen air (HPA) systems such as the DYE Throttle® air system. Do not use CO₂ or any other compressed gas. The output pressure from the air system has to be between 400 - 850psi. Also see Page 32 "Airport"

TO INSTALL AN AIR SYSTEM

- A. Make sure that the knob on the left of the ON/OFF airport is in the OFF position by turning the knob clockwise or up.
- B. Screw the tank into the airport until snug.
- C. Turn the gas supply on by turning the knob of the airport counter clockwise all the way to the locked position.

TO REMOVE AN AIR SYSTEM

- A. Turn the gas supply off by turning the knob of the airport clockwise until you hear gas escaping. This will de-gas the airport and make the air system easy to remove.
- B. Unscrew the air system counter-clockwise.

WARNING: EVEN WITH THE AIR SYSTEM REMOVED THERE CAN BE GAS INSIDE THE DAM™ AND IT CAN STILL FIRE A PAINTBALL. ALWAYS TREAT THE MARKER AS LIVE AND NEVER POINT IT AT ANYTHING YOU DO NOT WANT TO SHOOT!



DAM™ BOARD

SETTINGS AND FUNCTIONS

DAM™ CONTROL PANEL

Located on the left side of the DAM™ and above the grip, the DAM™ Control Panel controls the Power (1), Fire Selection (2), Electric Eye Function (3) and Circuit Board Programing (3)+(1).

TURNING THE DAM™ ON AND OFF

To turn on the DAM™, press and hold the Power Button (1) until the LED's turn blue. The BLUE light indicates board boot up. After the boot up sequence, the rear LED (3) will turn either RED (no ball) or GREEN (ball in breech, ready to fire). To turn the DAM™ off, press and hold the Power Button (1) until all LED's turn off.



NOTE: The DAM™ automatically switches off after 10 minutes of inactivity.

FIRING THE DAM™

As soon as the marker is turned on and the rear LED turns from BLUE to either RED or GREEN, the DAM™ is ready to fire. If there is no ball and the rear LED is RED, you need to hold the trigger for 1 second to force the DAM™ to fire once. If there is a paintball inside the breech and the rear LED is GREEN, just press the trigger to fire the marker.

FIRE SELECTION

The DAM™ comes with a Fire Selector Button (2). The first time the DAM™ is powered up from the factory, it will be in Semi-Automatic mode. Press the Fire Selector and the DAM™ will be in 3-Round Bust mode. Press it again and the DAM™ will be in Fully Automatic mode. Press it a third time to return to Semi-Auto mode. Notice that as the modes are cycled the three BLUE indicator lights change. These indicate the number of the mode. 1 is always Semi-Auto while modes 2 and 3 are programmable. Also see Page 13 DAM™ Board Settings and Functions

DAM™ BOARD

SETTINGS AND FUNCTIONS

LED LIGHT INDICATOR

The DAM™ uses several super bright LED's mounted on the circuit board inside the grip frame. These lights are used to provide information to the user about the DAM™. The LED's are located on the left side of the DAM™ above the grip frame while holding it in a firing position.



NOTE: The eye is always activated when you turn the marker on.

When you turn on the marker in normal operation mode with the power button, the light colors mean the following

- | | |
|----------------|--|
| Blue | - Boot sequence |
| Red | - Breech is clear, no ball detected inside the DAM™ (eye is on) |
| Green | - Ball in breech, ready to fire (eye on) |
| Blinking Red | - Eye is turned off |
| Blinking Green | - Eye failure, eye is blocked or dirty (see DAM™ Eye, page 29) |
| Blinking Blue | - Indicates a low battery; change the battery as soon as possible. |

To turn off the eye feature press and hold the rear button (3) until the LED light starts blinking Red indicating the eye feature is turned off.



When servicing your marker:

- Make sure a barrel sock is fitted to the DAM™.
- Make sure your loader/magazine is removed from the DAM™.
- Make sure there are no paintballs in the breech of the DAM™.
- Always remove the first stage regulator and relieve all residual gas pressure from the DAM™ before disassembly.
- The DAM™ can hold a small residual charge of gas, typically 2 shots, with the first stage regulator removed. Always discharge the marker in a safe direction to relieve this residual gas pressure.

DAM™ BOARD

SETTINGS AND FUNCTIONS

BOARD SETTINGS AND CONFIGURATION MODE

There are five settings to alter on the DAM™ board including two DIP switches inside the gun body

Trigger Sensitivity	Adjusts the delay between two trigger pulls.
Dwell	This is the time the solenoid is activated for.
Rate Of Fire	Adjusts the maximum rate of fire.
Firing Modes	Configures the different firing modes on the DAM™.
Factory Reset	Puts the DAM™ in its original configuration.
Configuration Lock	Disables the Configuration Mode

DIP SWITCHES - There are two DIP switches mounted on the board of the DAM™. These switches can be accessed by removing the left side of the Tool-less Grip and exposing a hole at the top of the grip frame and on the underside of the body. Use a 3/32" Allen wrench to activate the DIP switch. When the switch is towards the Front of the gun (Forward) is OFF (Default position) and when it is towards the Back of the gun (Backward) is ON. The first one returns the DAM to Factory settings and the second blocks access to the configuration mode.



FACTORY RESET SETTING - When the #1 DIP (Left) switch is ON (Backward), the DAM™ circuit board is temporarily reset to the factory specified settings. Use this mode to trouble shoot the DAM™. When the #1 DIP switch is OFF (Forward), the circuit board will return to the user defined previous settings.

NOTE: When in the Factory Reset Setting the Board is still programmable and all changes WILL be saved. However these changes will not take effect until the #1 DIP Switch is turned OFF (Forward)

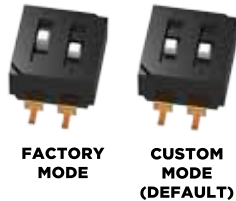

DAM™ BOARD

SETTINGS AND FUNCTIONS

CONFIGURATION MODE - The following settings can only be modified in Configuration Mode. To activate the configuration mode, turn your marker off. Next, hold down the Eye Button (3) and turn your marker on. The LED's cycle through all colors for one second to indicate that you have entered the configuration mode.

To cycle through different settings, pull and release the trigger. Configuration mode has 6 settings that can be changed. To exit configuration mode, hold down the Power button.



TO CHANGE A VALUE OF A SETTING

- While in the configuration mode, choose the color you wish to change by pulling the trigger to cycle through different options.
- When the LED indicates the color you wish to change, pull and hold the trigger until the LED starts to flash.
- The LED will flash as many times equal to the previous setting. Then it will turn off. Now pull the trigger a number of times equal to the desired setting - if you do not wish to alter the value of the setting, you must re-enter the previous value.
- The LED will cycle through all the colors again to indicate the setting was saved and finally turn back to **GREEN**. You can now change another setting or exit the configuration mode.
- To exit configuration mode, set DIP 2 to the off position.

CONFIGURATION LOCK - Some locations may require the DAM™ to be limited in its function. To block access to the configuration mode turn the #2 DIP (Right) switch ON (Backward). The configuration mode will no longer activate. To access configuration mode, turn the 2 DIP switch OFF (Forward) and activate normally.

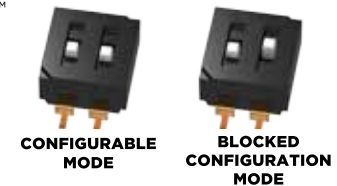

DAM™ BOARD

SETTINGS AND FUNCTIONS



GREEN - Trigger Sensitivity Values 1 - 20 (factory default 3)

Trigger sensitivity is the amount of time that the trigger has to be released before the next trigger pull is allowed. In some situations with too low of a value, the DAM™ can register more trigger pulls than what was actually pulled. This can cause the DAM™ to fire at full-auto, even in semi-automatic mode. To fix this, adjust the trigger sensitivity setting higher.



RED - Dwell Values 1 - 30 (factory default 20)

Dwell is the amount of time that the solenoid will be activated. Follow these steps for the best way to set your dwell:

- Remove loader and any paintballs from the DAM™ marker.
- With the dwell set at 10, start increasing the value until the marker begins to fire.
- When you reach the setting where the marker begins to fire, get some paint and a loader and go to a chronograph.
- Increase the dwell until you see no increase in the velocity. This is the optimal dwell setting to be used.



BLUE - Rate Of Fire (ROF) Values 1 - 45

The ROF setting is used to set the maximum rate of fire of the DAM™. The values do not correspond directly to a certain Balls Per Second (BPS) value. You will need to use the table below to locate your desired maximum ROF setting. The factory setting is **20 (12.5 bps)**.

1 9.80 BPS	10 10.75 BPS	19 12.34 BPS	28 13.88 BPS	37 15.87 BPS
2 9.90 BPS	11 10.86 BPS	20 12.50 BPS	29 14.08 BPS	38 16.12 BPS
3 10.0 BPS	12 10.98 BPS	21 12.65 BPS	30 14.28 BPS	39 16.39 BPS
4 10.10 BPS	13 11.11 BPS	22 12.82 BPS	31 14.49 BPS	40 16.66 BPS
5 10.20 BPS	14 11.62 BPS	23 12.98 BPS	32 14.70 BPS	41 20.00 BPS
6 10.30 BPS	15 11.76 BPS	24 13.15 BPS	33 14.92 BPS	42 20.22 BPS
7 10.41 BPS	16 11.90 BPS	25 13.33 BPS	34 15.15 BPS	43 25.0 BPS
8 10.52 BPS	17 12.04 BPS	26 13.51 BPS	35 15.38 BPS	44 28.57 BPS
9 10.63 BPS	18 12.19 BPS	27 13.69 BPS	36 15.62 BPS	45 33.33 BPS

Increasing ROF too high will increase the probability of ball breakage. If this occurs decrease ROF setting.

DAM™ BOARD

SETTINGS AND FUNCTIONS



PURPLE - Firing Mode 1 Values 1 - 4 (default 1)

This setting changes the second firing mode of the DAM™. Default is 3 Round Burst. In the 3 Round Burst mode, one trigger pull shoots out three paintballs. The PSP mode and the Millennium modes follow the rules of each respective paintball tournament series.

- Value 1** - 3 Round Burst
- Value 2** - Full auto with first shot safety feature
- Value 3** - PSP Mode
- Value 4** - Millennium Mode



YELLOW- Firing Mode 2 Values 1 - 4 (default 2)

This setting changes the third firing mode of the DAM™ Fire Selector button. Default fully-automatic. In full-auto mode, holding the trigger down will fire a constant stream of paintballs at the selected rate of fire. The PSP mode and the Millennium modes follow the rules of each respective paintball tournament series.

- Value 1** - 3 Round Burst
- Value 2** - Full auto with first shot safety feature
- Value 3** - PSP Mode
- Value 4** - Millennium Mode



WHITE - FIRE SELECTOR LOCKOUT Values 1 - 2 (default 1)

This setting will lock the DAM™ to the fire mode last selected with the Fire Selector button. For example, if the gun needs to be used in a PSP tournament follow this procedure. Program the "Purple - Firing Mode 1" to Value 3 "PSP Mode," exit configuration mode, select the second firing position (two lights) with the Fire Selector button to put the gun into PSP Mode. Then reenter configuration mode and set the White - Fire Selector Lockout to Value 2. Upon exiting configuration mode the DAM™ will be locked into PSP Mode. To fully lock the DAM™ for tournament play the 2 DIP switch should be turned on to initiate the Configuration Lock. To return the gun to normal Fire Selector Operation, simply switch back to Free Mode.

- Value 1** - Free Mode
- Value 2** - Locked Mode

TRIGGER ADJUSTMENT

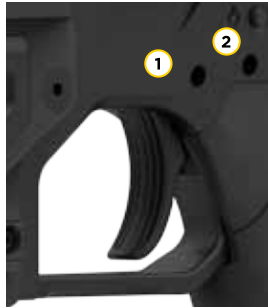

ADJUSTING YOUR TRIGGER

The Trigger's Forward and Over-Travel are fully adjustable so that you can fine-tune the trigger to your exact liking. You do not need to remove the frame or grip to adjust the trigger pull.

There are 2 adjustment screws located on the left side of the Ultralite™ Frame.

To adjust trigger travel

- A. Use a 5/64" Allen wrench to make the desired adjustments.
- B. The screw toward the front of the trigger **(1)** controls the forward travel. Screwing it in will shorten the trigger's pull length.

NOTE: if the screw is adjusted too far IN, the switch will be held at all times and the marker will not fire.

C. The screw toward the rear of the trigger **(2)** controls the over travel. By turning this screw you can adjust how far the trigger will travel after it reaches the firing point.

NOTE: if this screw is adjusted too far IN, the trigger will not be allowed to travel far enough to depress the switch and fire the marker. However if it is adjusted too far OUT, the circuit board can be damaged.



- Be sure the trigger is not adjusted to the point where it is too sensitive and may cause accidental discharge of the marker.
- Removing the trigger spring will cause premature wear on the microswitch, resulting in failure.

TO ADJUST TRIGGER SPRING TENSION

Remove the sticky grip from the grip frame following the instructions on Page 4. This will expose the brass Spring Adjustment Knob **(3)**. Screw the knob in the clockwise direction to reduce spring tension. Unscrew the knob counter-clockwise to increase spring tension.

NOTE: Do not unscrew too far or the bolt will come loose. Make sure there is always at least 4-5 threads left for a secure hold.

If you find that the spring tension is inconsistent, add a small drop of thread adhesive to the tip of the brass threads and let dry before re-installing. This will create light resistance when turning the knob and ensure it holds after many activations of the trigger.

BATTERY

The 9V battery will last for about 40,000 shots. Please be aware that there are substantial differences in performance between different brands of batteries. Use of high quality alkaline or lithium ion batteries is recommended for maximum battery life. If you do not plan to use your marker for a long period of time (a month), it is recommended that you remove the battery from the marker. When the battery voltage starts to get too low, the marker will not fire with every trigger pull or worse. For tournament use, it is recommended to change the battery for each tournament.



CHANGING THE BATTERY

The battery is housed inside the grip frame. To access the battery, free either side of the tool-less grip by placing a finger in the groove located at the rear of the grip frame and pull away from the marker. When inserting a new battery, notice the shape of the connectors. The battery can only be installed one way.

NOTE: If the marker will not function with the eyes on, a battery change is recommended.

DAM™ BOLT

ASSEMBLY AND MAINTENANCE



The DAM™ BOLT is the main component of the DAM™ marker. In order to achieve the best possible performance of the DAM™ it is essential that the DAM™ BOLT is kept clean, well lubed and in good working order.

The DAM™ BOLT should be cleaned and re-lubed after each day of use.

There are 3 parts in the DAM™ BOLT kit that mount together with the regulator to form one unit. To remove the DAM™ BOLT/HYPER 3™ IN-LINE REGULATOR assembly from your DAM™, pull the tool-less back cap away from the marker and turn the Back Cap out 2 full turns counter clockwise. Now pull out the complete DAM™ bolt kit from the DAM™. If the bolt cannot be removed by hand, use a 1/4" Allen key to loosen it.

To disassemble the DAM™ bolt kit, unscrew the front-most part called the "Can" from the Manifold. Then pull out the actual moving bolt from inside these pieces. Notice that to separate the Can and the Bolt you need to remove the bolt tip O-ring before the bolt is able to slide through the Can.

HOW IT WORKS

Air is supplied into two points on the DAM™ BOLT. In the back air is routed through the In-Line Regulator and Manifold and fills up the supply chamber around the Manifold. In front, air is routed through the Sail on the Bolt, which keeps the bolt in the back position.



FORWARD POSITION



BACK POSITION

DAM™ BOLT

ASSEMBLY AND MAINTENANCE



When the DAM™ is fired the solenoid is actuated and the air inside the Can is exhausted out. The force created by the air inside the supply chamber causes the bolt to start moving forward. Once the bolt has moved about half way forward, the tail of the bolt closes the input into the supply chamber. Once the Bolt reaches the forward point, the

valve of the DAM™ Bolt is opened and air inside the supply chamber goes through the Bolt and fires the paintball. After this the solenoid is deactivated and gas is supplied through the solenoid back into the Can. This causes the Bolt to return to the back position and the supply chamber to be re-charged.



When servicing your marker:

- Make sure your loader and magazine are removed from the marker.
- Make sure there are no paintballs in the breech of the marker.
- Always remove the air supply and relieve all gas pressure in the marker before disassembly.
- When using the marker in temperatures below 50° Fahrenheit it may be necessary to lube the DAM™ bolt more frequently.

DAM™ BOLT

ASSEMBLY AND MAINTENANCE

MAINTENANCE

The basic maintenance for the DAM™ BOLT is to clean all surfaces of dirt, broken paint or other debris, check for any wear and tear on the O-rings and change them if needed, and finally to apply a thin coat of DYE Slick Lube on all surfaces. Before installing the DAM™ BOLT back to the DAM™ marker check that the bolt moves freely with minimal friction and make sure all pieces are threaded together snugly. Do NOT over tighten. If the DAM™ BOLT is not kept clean and well lubed, you will either start seeing erratic velocity, air leaks or over a long period of time, and physical damage to the DAM™ BOLT components. For troubleshooting leaks and other bolt problems, consult the Troubleshooting section at the end of this manual.

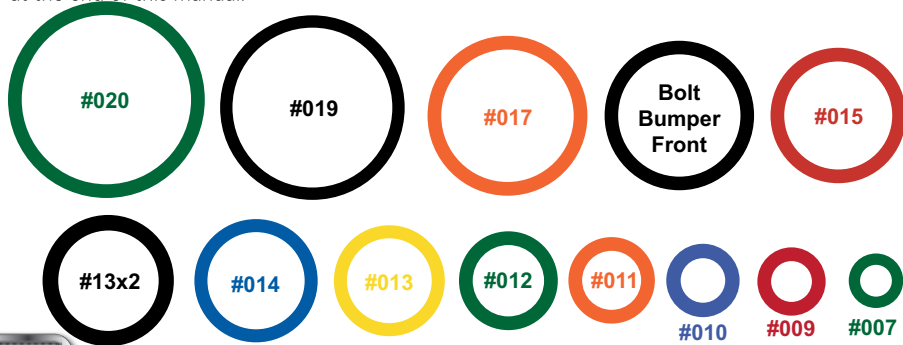

DAM™ BOLT

ASSEMBLY AND MAINTENANCE

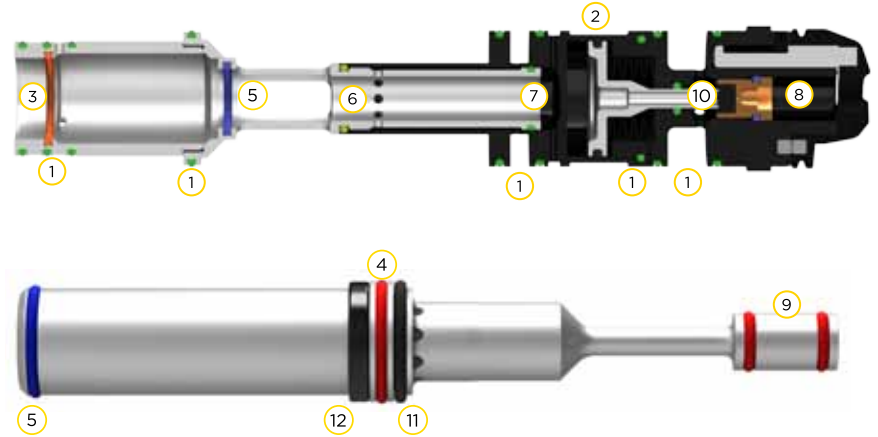

DAM™ BOLT O-RING LIST

1	020	N 70	7	012	N 70
2	019	N 70	8	010	N 70
3	017	N 70	9	009	N 90
4	015	N 70	10	007	UR 90
5	014	N 70	11	013x2mm	N 90
6	013	N 70	12	Bolt Bumper Front	N 90

HYPER™ IN-LINE REGULATOR

ADJUSTMENTS AND MAINTENANCE

VELOCITY ADJUSTMENT

The velocity of the DAM™ is controlled by adjusting the input pressure into the DAM™ with the In-Line Regulator. The In-Line Regulator on the DAM™ is factory set to 150 psi which will give you a velocity of about 285 FPS (Feet per Second).

A 3/16" Allen key will be needed for this operation. Turning the adjustment screw inward (clockwise) will decrease the pressure, and outward (counterclockwise) will increase the pressure. The adjustment screw is located inside the back cap of the bolt. To adjust the velocity:

1. Make sure you and everybody around you is wearing ASTM/CE approved paintball goggles.
2. Shoot the DAM™ over a paintball chronograph.
3. To lower the velocity turn the In-Line Regulator adjustment screw in. To increase the velocity turn the screw out. Only turn the screw a quarter turn at a time and shoot over the chronograph again. Notice that a few shots are needed before the change can be seen on the chronograph.



MAINTENANCE

For the DAM™ to function properly, it is essential that the input pressure into the marker stays consistent. The general maintenance needed for the Hyper™ In-Line regulator is to keep it clean of dirt and debris at all times. A more extensive service should be performed every 12 months by a trained Tech or if the output pressure of the regulator is not consistent. This can be verified with a regulator tester (sold separately). Notice that the In-Line Regulator has a break-in period of about 2000 shots before it achieves the best performance.

HYPER™ IN-LINE REGULATOR

ADJUSTMENTS AND MAINTENANCE

HYPER IN-LINE REGULATOR DIS-ASSEMBLY INSTRUCTIONS

A. With the bolt removed from the DAM™, unscrew the 3 set screws (1) that retain the Tool-Less Back Cap. The screws have thread adhesive and will be difficult to remove. When reassembling be sure to re-apply thread adhesive and let dry. Then re-insert screws deep enough to clear the chamber walls but shallow enough to allow the back cap to slide.

NOTE: During reassembly, re-apply thread adhesive to the set screws and let dry. Re-insert the screw far enough to clear the chamber walls but shallow enough to allow the Back Cap to slide.

- B. Use a pair of Retention Clip Pliers to remove the C-clip inside the Back Cap housing.
- C. Unscrew the brass seat housing from the body with a 3/16" Allen key.

To change the regulator seat

- A. Pull out the old seat from the housing with a sharp object.
- B. Insert the new seat and push it down with a flat object.

Notice that it takes about 2000 shots for the seat to perfectly set into the seat housing. This is called the break in period for the regulator. Remember to apply lube to the O10 O-ring on the screw before re-assembly. Further disassembly to service the internal section of the Hyper In-Line Regulator should be performed by a trained Tech.

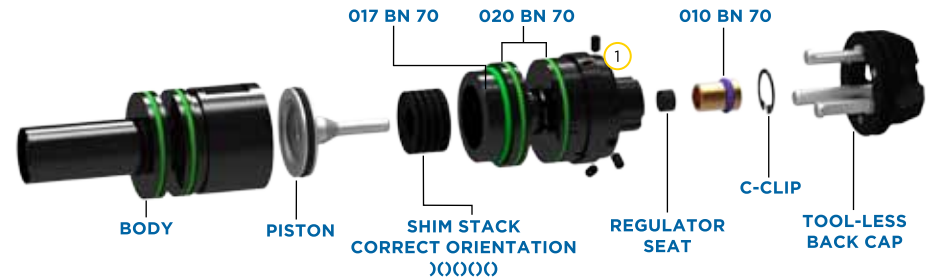

MAGAZINE OPERATION

MAGAZINE FED OPERATION

The DAM™ is designed to use the Dye Tactical Magazines (DTM) and is ready out of the box for any style of magazine play. All DTM's are Shaped Projectile Ready and mimic the operation of traditional ammunition magazines.



WARNING: Loaded magazines will eject paintballs as soon as the cover door opens. Do NOT open Cover Door while magazine is pointed at your face or anyone else's face! For safety, always place you hand over the top of a magazine before opening Cover Door.

NOTE: Due to the nature of magazine operation it is highly recommended that operators use the highest quality paintballs available. This will ensure peak performance from the DTM.

1) Loading - To load the DTM

A. For safety, firmly place your hand over the top of the magazine and then open one of the Cover Doors (1) with your thumb. Push all the way down to free the bumper retainer. It is now safe to remove your hand and begin loading.

NOTE: Do NOT open Cover Doors after loading paintballs. Paintballs will immediately eject. Cover Door will automatically open when loaded into the DAM.



MAGAZINE OPERATION

MAGAZINE FED OPERATION CONT.

B. Place a paintball on the exposed bumper and press down with your thumb. (2) Press firmly but do not damage the paintball. When using shaped rounds be sure to load them with the front faced towards the center of the magazine. The Cover Door (3) will retain the balls until loading is complete. Do NOT touch the Cover Door Tab (4) or the balls will immediately eject!



C. Once 5 or 10 balls are loaded into the DTM (depending on magazine capacity) press gently downward to engage the bumper retainer. This will hold the spring down and ensures your paintballs do not dimple during prolonged storage.

D. Without touching the Cover Door Tab (4), press the Cover Door Release (5) found directly under the cover door tab. With the cover door closed, your paintballs will be protected from debris and moisture and ensures the best quality ammunition.

E. Repeat steps (B-D) for the second chamber.



WARNING - DO NOT depress bumper without paintballs in the DTM. In rare occasions releasing a locked bumper without paintballs in place can seriously damage the DTM. NEVER discharge a fully locked bumper at yourself or anyone else.

MAGAZINE OPERATION

MAGAZINE FED OPERATION CONT.

2) Firing - To fire paintballs, including shaped rounds, from your loaded DTM;

A. Set up your DAM™ following the steps in the “Quick Start Guide” found on Page 4. Also, ensure that you and all others in the area are wearing ASTM/CE certified paintball goggles.



WARNING: After the following step, the DAM™ will be live and fire a paintball at the next trigger pull. Keep your DAM™ pointed away from anything you DO NOT want to shoot!

B. Insert your loaded DTM into the Receiver Well. You can begin firing from either side.

C. Slide the On-the-Fly (OtF) switch to the Magazine Fed (Forward) position. When the OtF switch is in the forward position, a paintball is loaded into the breech and your DAM™ is live and ready to fire.

D. After 5-10 shots (depending magazine capacity) the first chamber of you magazine is empty. To load the second chamber, press the magazine release button located on the magazine receiver well in front of the trigger guard on the left or right side. Once removed, rotate the magazine horizontally so that the unopened chamber is closest to you and reinsert.

E. Once ammunition is depleted, repeat steps (B-D) with another loaded magazine until all enemies are eliminated, you are eliminated or you run out of paint.

MAINTENANCE

MAGAZINE OPERATION

Your Dye Tactical Magazine requires very little maintenance due to its minimalist design. Cleaning ensures long term functionality. DO NOT point the magazine at yourself or anyone else while unloading.

To Clean

- A. To safely clean the DTM place your hand firmly over the top of the magazine, hold the cover door down **(6)** and slowly feed the paintballs into your hand. Clear all paintballs from both chambers.
- B. Remove the bottom Access Door **(7)**. Note: Access Door can only be removed in one direction. With the door removed, pull the cover door all the way down **(6)** which retracts the bumper retainer and allows the bumper **(8)** and the spring **(9)** to slide out of the magazine. Repeat for the second side.
- C. Use a barrel swab to clean the inside of the magazine, clean off bumper **(8)**, spring **(9)** and Access Door **(7)** with a damp cloth.
- D. Reassembly. Insert both sets of bumpers **(8)** and springs **(9)**. Being careful not to catch or pinch the springs, re-insert the access door **(7)**. The access door can be inserted on either side.

Your magazine is now clean and ready to go. Always clean your magazine in the event of paint breakage in or above (i.e. the breech) the magazine. While the magazine rarely fails due to debris or dirt, it will affect your paintballs and their accuracy. A clean loader, paintball and barrel give the best accuracy in all situations.

Store out of sunlight in a cool place and away from chemical fumes (such as gasoline or engine exhaust). Long term exposure to direct sunlight, chemicals and large temperature fluctuations will damage your magazines.

It is NOT recommended to store you magazines in a loaded state for longer than 24 hours. Prolonged periods in a compressed state can damage the spring and will reduce loading effectiveness.

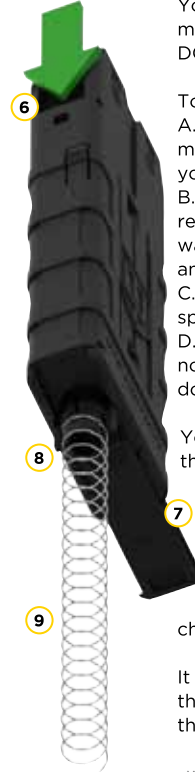

ACCESSORY MOUNTING

The DAM™ comes standard with over 2 feet of standard Picatinny mounting: a rail system recognized and used by military forces and sovereignties worldwide. Most standard military equipment will mount to these rails in the same way as described in their instructions. For accessories that must slide onto the rails for mounting, the front cap and/or loader adaptor may have to be removed temporarily.

The DAM™ shroud assemblies' modular design allows for ultimate customization. All side and bottom rails can be removed with a 3/32" Allen wrench and configured as desired. The 2 piece design of the shroud also allows for one section to be removed for a more compact configuration. Alternatively the front cap can be removed and installed directly onto the DAM™ creating the shortest configuration of the gun for room clearing battles and tournament play.

To Remove the shroud:

- A. Remove the foregrip by completely unscrewing the fastener located on the right side with a 1/8 Allen wrench. Slide the fore grip forward and clear of the magazine receiver well.
- B. Use a 3/32" Allen wrench to remove the countersink screws located at the top on the Picatinny rail and on the bottom in front of the magazine receiver well. Then slide the shroud assembly forward and clear of the barrel.

The shroud can be disassembled by removing the bottom rails and the screws underneath.

The DAM™ has proprietary mounting for a stock. The DAM™ comes with the stock attachment cover installed. Always use the stock attachment cover whenever a stock is not in use. An air-through plug rests behind the cover and will allow for future products to pass air through your stock attachment. The stock cover attachment will keep this plug safely secured when a stock is not used.



ACCESSORY MOUNTING

To Install the Stock:

- A. With a 3/32" Allen wrench, loosen the set screw found at the extreme rear bottom of the DAM™ (1). 3 turns should be enough. Slide the stock attachment cover rearward and off the gun.
- B. Slide the stock rod into place. Make sure the grooves line up properly before sliding. With the stock rod fully seated use a 3/32" Allen wrench to tighten the set screw found on the bottom front of the stock rod, until snug. Do not over tighten.



LOADERS AND FEED NECK

LOADERS AND FEED NECK

To achieve the maximum performance of the DAM™ you will need to use a motorized loader that force-feeds paintballs into the DAM™ marker, preferably the Rotor™ Loader. Using a slower motorized loader or a non-motorized loader will work, but the rate of fire and performance will be reduced.

TO FIT A LOADER ONTO THE DAM™:

The Cam Lever Feedneck is adjustable to fit any standard loader. To adjust the cam locking system, lift the cam lever away from the feed collar, and rotate the lever clockwise to tighten or counterclockwise to loosen the grip on the loader. Once the cam lever is facing in the forward direction, press the cam lever down against the feed collar to secure the loader in the feedneck. To loosen the locking system and remove the loader, lift the cam lever away from the feed collar. Take care not to over-tighten the cam locking system. The lever should not be overly difficult to lower into the locked position.



ANTI CHOP EYES/ BALL DETENTS MAINTENANCE AND CHANGING

ANTI CHOP EYES

The Anti Chop Eye (ACE) system will prevent the DAM™ from chopping paint by not allowing the marker to fire until a ball is fully seated in front of the bolt. The eyes use a beam across the breech. On one side there is a transmitter, and on the opposite side a receiver. In order for the marker to fire with the eyes turned on, the signal between the two eyes must be broken. After every shot, before the next ball drops in the breech, the eye transmitter and receiver must see each other. If the eyes are dirty and cannot see each other between shots, the LED on the board will start blinking green. This means that the eyes are dirty. This is an extremely reliable system as long as the eyes are kept clean. The most common reason for dirty eyes is broken paint. If the eyes become dirty, the marker will default to a reduced rate of fire to prevent chopping. If this happens during game play, you can bypass this by turning the eyes off. Clean the eyes as soon as possible.



NOTE: IF THE BATTERY IS LOW, THE MARKER MAY ACT AS IF THE EYES ARE DIRTY OR NOT FIRE AT ALL. IN THIS CASE, REPLACE THE BATTERY.

SELF CLEANING EYE FEATURE

The DAM™ is equipped with a self-cleaning eye feature. There is a clear poly-carbonate sleeve mounted inside the breech of the gun covering the eyes. When the bolt tip O-ring passes through the Eye Pipe, it sweeps off any dirt, grease or paint that could be blocking the eyes. Normally this is enough to just fire the DAM™ to clean anything blocking the eyes. If this does not clear the blockage use a swab to clean the inside of the breech.

ANTI CHOP EYES/ BALL DETENTS MAINTENANCE AND CHANGING

MANUAL CLEANING

For a more thorough cleaning, remove the Rotating Eye Pipe. There are two methods:

WITH SHROUD ASSEMBLY INSTALLED

A. Use a 3/32" Allen key to loosen the set screw located inside the hole at the front of the top picatinny rail.

B. With the barrel installed pull the barrel and the barrel carrier as far forward as possible.

C. Remove - Rotating Eye Pipe **(1)** and Eye Platform **(2)** can now be removed through the magazine Receiver Well **(3)**.

WITH SHROUD ASSEMBLY REMOVED

A. Use a 3/32" Allen key to loosen the set screw located inside the hole at the front of the top picatinny rail.

B. With the barrel installed pull the barrel and the barrel carrier out of the front of the DAM™.

C. Pull the Rotating Eye Pipe **(1)** out through the front.

D. With the Rotating Eye Pipe out, use a swab to clean the breech. This should be enough to clean the eye system. If the system needs further cleaning, use a 3/32" Allen wrench to remove the Receiver Well **(3)** to fully access the electric eyes. To prevent damaging the eye wires, it is best to remove the frame and disconnect the eye wires from the board. Use a soft rag and cotton swabs to clean off any built up paint or grease.

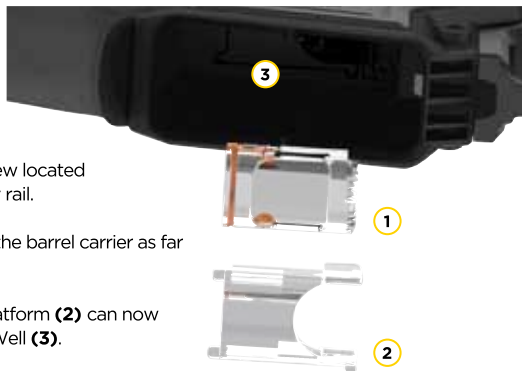

ANTI CHOP EYES/ BALL DETENTS MAINTENANCE AND CHANGING

When re-assembling the Eye Pipe system, work backwards from disassembly. The Rotating Eye Pipe must be aligned properly for the On the Fly system to work.

A. Push the On the Fly Switch to the forward/bottom-feed position.

B. Align the Rotating Eye Pipe **(1)** feed-hole to the bottom-feed hole and push back to fully seat against the spur gear.

C. Replace the Eye Platform **(2)** and then the Barrel and the Barrel Thread Carrier. The Barrel Thread Carrier is keyed to the hole and can only be installed one way.

D. Tighten the top set screw to secure the Barrel Carrier.

NOTE: REGULAR EYE CLEANING IS RECOMMENDED EVEN IF NO PAINT IS BROKEN. CLEAN THE EYES EVERY TWO MONTHS OR 10,000 SHOTS TO ELIMINATE ANY BUILT UP DIRT. EXCESS GREASE CAN BUILD UP IN FRONT OF THE EYES. REMEMBER TO CHECK FOR THIS AFTER GREASING THE BOLT AND CYCLING THE MARKER A FEW TIMES.

CHANGING BALL DETENTS

The ball detent system is clipped to the outside of the Rotating Eye Pipe. The ball detent system needs little or no maintenance. The detents should easily flex out of the way with little force, such as a paintball moving past. If you are experiencing double feeding or chopping, check the condition of your ball detents with your finger to make sure they are not broken, stuck in the up or down position, and that they move in and out of the breech freely. If excessive broken paint or dirt has jammed your ball detents, remove the Eye Pipe/ detent system through the magazine well of the DAM™ and remove the detents for a thorough cleaning. Reinstall the detents and Eye Pipe after you have sufficiently cleaned the detents and breech. Be careful not to over-flex the detents when handling them. Excessive flexing could break or damage the detents.

NOTE: TAKE CARE WHEN REPLACING THE EYE PIPE. BE CAREFUL THAT THE DETENT CLIP IS FULLY SEATED ONTO THE EYE PIPE.

AIRPORT

ASSEMBLY AND MAINTENANCE



ON/OFF AIRPORT DISASSEMBLY AND ASSEMBLY

REMOVE PIN HOUSING ASSEMBLY

To disassemble the UL™ airport use the airport tool included on the DYE Multi-Tool (available separately).

- Insert the airport tool into the Pin Housing and turn counterclockwise 3-4 revolutions. Note that the airport lever must be in the OFF position for the tool to grab the housing. Remove housing out of the airport body.
- The pin and **005 O-ring** may or may not come out with the housing, if necessary use a pair of needle-nosed pliers to pull the pin out and a dental pick to remove the **005 O-ring**.

INSTALL PIN HOUSING ASSEMBLY

- Coat the **005 O-ring** in lube and drop it into the airport body. Use a 1/4" Allen wrench to fully seat the O-ring in place by pushing gently on it.
- Insert the Pin into the Pin Housing from the backside.
- Place the housing onto the airport tool and insert the housing into the airport body.
- Turn clockwise until the Pin Housing fits snugly into the airport body.
- * If the airport tool is not available, a pair of needle-nose pliers can be used to unscrew the Pin Housing. Just take care to not scratch or damage the threads or Pin Housing.

NOTE: For exploded view of airport and parts list see page 36.

TROUBLE SHOOTING GUIDE

AIR LEAKS

AIR LEAKING FROM THE AIRPORT

- Check the O-ring on the air system. If needed change the O-ring and try again. The O-ring normally used is an O15/70 but some manufacturers might use a different size. Consult the manual of the air system you are using.
- Replace the #006 O-ring located inside the airport. This can be disassembled using a 3/16" Allen wrench and a 7/16" socket.
- Check that the hose connector is tight. Use a 7/16" Allen key to tighten. If needed remove and apply thread sealant to the thread and re-tighten. If unsure consult expert advice.
- Check that the end of the hose is cut straight and is not worn out. If needed cut a small piece off the hose with a razor blade and re-insert hose into the fitting. Make sure hose goes all the way to the end.

AIR LEAKING BETWEEN BODY AND FRAME

- Firstly, check that the In-Line Regulator input pressure has not been adjusted too high or too low.
- The other possibility is that one of the gas passages is leaking. Gas up the DAM™ without the frame attached and try to locate the exact point of leakage. If the leak is coming from one of the blocked holes remove the screw, apply some thread sealant and re-attach

screw to the body.

- If the leak comes from the small hole on the bottom of the DAM™ body directly below the In-Line Regulator then consult a trained technician before attempting to disassemble the In-Line Regulator.

AIR LEAKING FROM BACK OF THE DAM™

- Check that the bolt kit is tightened all the way into the DAM™. If the bolt kit is loose, it will start to leak.
- If the leak is coming from the Back of the regulator you will need to disassemble the regulator and change the #010 O-ring and the seat on the brass seat retainer mounted inside the In-Line Regulator.
- If above does not solve the leak, remove the bolt kit and change the #020 O-ring on the back cap of the bolt. Also change the two #009 O-rings located on the tail of the bolt. Lube well and re-insert the bolt kit into the DAM™. Check bolt kit break down picture on page 19 for O-ring locations.
- Last, check that the gas passage blocking screw located on the right side of the DAM™ is not leaking. If the leak is coming from this hole, remove screw and apply thread sealant to it. Make sure to tighten the screw well and wait for sealant to dry (24-48 hours) before re-gassing marker.

TROUBLE SHOOTING GUIDE

AIR LEAKING FROM FRONT OF THE DAM™

- Remove the Bolt kit from the marker and change the #017 O-ring located inside of the Can and the #014 O-ring located inside the Manifold. Lube well and re-assemble.
- If above doesn't help, try changing the #020 O-rings located outside of the Can. Lube well before re-inserting bolt kit.

PROBLEMS WITH ELECTRONICS

DAM™ WON'T TURN ON

- Make sure battery is new and well charged.
- Check that battery dongle is connected to the DAM™ Circuit board
- Make sure there is no dirt or debris blocking the button from being pressed.

DAM™ WILL TURN ON / OFF BY ITSELF OR THE EYES WILL TURN ON / OFF BY THEMSELVES

- Both of these problems are caused because the button(s) are being held down, as if they are pressed all the time.
- Remove board from the frame by removing the grip frame, disconnecting the cables and removing the board. Carefully remove the circuit board buttons and clean them well.
- Re-assemble and test. If problems persist, contact authorized service center.

EYES WILL NOT WORK, LED KEEPS BLINKING GREEN

- Check that the eye wire is properly connected to the board.
- Change the battery. The eyes are normally the first thing to stop working when a battery is dying.
- Next try to clean the eyes. See page 30 for details on how to remove the Rotating Eye Pipe and clean the eyes.

To test if the eyes work make sure there is nothing inside the breech and that the bolt is in the back position. Turn on the DAM™, the light should be red after the boot up sequence. If it is, the eyes are working.

SOLENOID WILL NOT ACTIVATE / TRIGGER NOT WORKING

- Check that the trigger is able to press the microswitch. You should hear a small click when pulling the trigger.
- If the DAM™ fires once when turned on but not after that, your trigger is set so that the micro switch is always activated. Re-adjust the trigger.
- Change the battery if you are not sure that it is new.
- Check that the solenoid cable is attached to the board and to the right connector.

TROUBLE SHOOTING GUIDE

TRIGGER BOUNCE / DAM™ SHOOTING MORE THAN ONE BALL PER PULL IN SEMI AUTOMATIC MODE

- Raise the trigger sensitivity level in the configuration mode.
- Check that the trigger is not adjusted too short.
- Make sure there is a trigger spring inside the frame.

ERRATIC VELOCITY / DAM™ WON'T FIRE

DAM™ FIRES BUT BALLS ARE DROPPING OFF OR NOT EVEN COMING OUT OF THE BARREL

- Make sure the battery is good.
- Raise the dwell to factory level (18).
- Make sure bolt is well lubed and moves well. If there is too much friction in the Bolt, it will cause the DAM™ to shoot down.
- Make sure air system is screwed in all the way and Air Port is locked into the On position.

FIRST SHOT IS TOO HIGH

- Change the Seat inside the Hyper3™ regulator. For disassembly instructions consult the technical section.
- Try turning off the ABS feature by turning DIP #1 to the off position.

VELOCITY IS NOT CONSISTENT

- Make sure the paintballs you are using fit the

barrel well and are consistent in size. The stock barrel with the DAM™ is .688 size.

You should be able to blow the paintball through the barrel but they should not roll through the barrel on their own.

- Remove the bolt kit and re-lube it. Change any O-rings causing a lot of friction. Make sure #014 O-ring in bolt tip is in place and in good condition.
- Raise the dwell.
- Change the battery.
- Check that the Hyper3™ regulator is working correctly and that the pressure is consistent.

OTHER CATEGORIES

DOUBLE FEEDING

- If you get two balls firing at once change the ball detents on the self-cleaning Eye Pipe.

BREAKING PAINT

- Make sure you use high quality paintballs and that they are stored according to the manufacturers instructions.
- Make sure your loader is working well and that the rate of fire is not set higher than the maximum feed rate of the loader.
- Check that the barrel you are using is not too tight for the paintballs you are using.
- Check the condition of the ball detents.

EXPLODED VIEW

DAM™ WARRANTY INFORMATION

WARRANTY AND LEGAL INFORMATION

PARTS LIST

- 1 DAM Bolt
- 2 Hopper Feed Cover
- 3 Barrel Thread Carrier
- 4 Eye Pipe Sytem
- 5 On the Fly System
- 6 Hyper™ In-Line Reg
- 7 DTM Reciever Well
- 8 Solenoid
- 9 Spring Tension Adjust
- 10 DAM Ultralite Frame
- 11 Air Through Frame
- 12 DAM™ Body
- 13 DTM
- 14 Modular Shroud
- 15 ISStock

WARRANTY

DYE Precision, Inc. warrants for one year to the initial retail purchaser, from the initial date of purchase, that the paintball marker and regulator are free from defects in materials and workmanship, subject to the requirements, disclaimers and limitations of this warranty. Disposable parts, normal maintenance and standard wear and tear parts such as batteries, O-rings and seals are not covered under warranty. The solenoid and electronic components on the marker are covered under warranty for six months. This warranty does not cover scratches, nicks, improper disassembly, improper re-assembly, misuse, neglect or improper storage. Modification to the product will void the warranty. The only authorized lubricant for the marker is Slick Lube™. Use of any other lubricant will void your warranty. This warranty is limited to repair or replacement of defective parts with the customer to pay shipping costs. Warranty card and proof of purchase must be submitted to DYE Precision for warranty to be in effect. This warranty is not transferable. This warranty does not cover performance. Paintball markers are non-refundable.

TECHNICAL SUPPORT

Our Technical Support Departments are open Monday through Friday. DYE Precision, Inc. can be reached at 858-536-5183 ext.277 from 9am to 5pm PST. DYE Europe can be reached at +44 (0) 20-8649-6330 from 9am to 5pm GMT. DYE Asia can be reached at 886 (0) 4-2407-9135 from 9am to 5pm GMT +8 hours. Additional support and international contacts are available through our web site, www.dyepaintball.com.

DISCLAIMER

The specifications & photographs in this material are for information and general guidance purposes only. Our products are continually updated and changes may be made to specification, design or appearance from time to time. These are subject to change without notice. Contents of box may therefore vary from owner's manual. For details of changes in design, specification or appearance consult your local distributor or dealer. The FUSE™ BOLT, DAM™, Hyper3™ and Slick Lube™ are registered trademarks. Design rights, copyrights and all other rights reserved. All patterns, drawings, photographs, instructions or manuals remain the intellectual property of the manufacturer.

DYE Precision, Inc. U.S. Patent # 5,613,483. OTHER U.S. AND INT'L PATENTS PENDING. Covered by one or more of the following U.S. Patents, 5,613,483; 5,881,707; 5,967,133; 6,035,843 and 6,474,326. For a complete list of patents please visit: www.dyeprecision.com/patents

DYE Precision, Inc.
10637 Scripps Summit Ct.
San Diego, CA. 92131

DYE Europe
Dye House,
7-8 Commerce Way
Croydon, Surrey
United Kingdom CR0 4XA

DYE Germany GmbH
Albert Einstein Str. 2 B
77656 Offenburg
Germany

DYE Asia
No. 253, Guojhong Rd.
Dali City, Taichung County 412
Taiwan (R.O.C.)

