



Thank you for choosing ARI AKON™.

ARI AKON™



www.ariakon.com

2794 LOKER AVE WEST
SUITE 107
CARLSBAD CA 92008

Phone: 1-877-4-ARI AKON
PHONE: 760-268-0735
FAX: 760-268-0736
Email: sales@ariakon.com



Read and understand the entire contents of this manual before attempting to use your marker!

ARI AKON™ All Rights Reserved.
ARI AKON, SIM, SIM-4, SIM-5, SIM-5N, SIM-15, TORO, ACP, ARI AKON COMBAT PISTOL and OVERLORD are trademarks of ARI AKON™
Any use or reproduction of materials, images, names, or logos found in this manual is strictly prohibited.

ARI AKON Manual Revision 1.0

Repair Authorization Form

This form must be included with your return. You must contact ARI AKON @ 760-268-0735 and obtain a Return Merchandise Authorization Number before sending your marker back. **ITEMS RETURNED WITHOUT AN RMA NUMBER ON THE PACKAGE WILL BE REFUSED.**

WARNING

THIS IS NOT A TOY. MISUSE MAY CAUSE SERIOUS INJURY OR DEATH. PROPER EYE AND FACE PROTECTION DESIGNED FOR PAINTBALL MUST BE WORN AT ALL TIMES BY THE USER AND ANY OTHER PERSON WITHIN RANGE. THIS PRODUCT IS NOT INTENDED FOR UNSUPERVISED USE BY PERSONS UNDER THE AGE OF 18. READ THE OWNERS MANUAL BEFORE USING THIS PRODUCT.

CO# _____

Name _____

Address _____

Phone () _____

Product: _____

Description of Problem:

Most repairs are completed within 3 to 5 business days. Any costs associated with parts and/or labor that is not covered by the warranty is the sole responsibility of the customer. Customers will be contacted prior to out of warranty repairs. Out of warranty repairs will be charged at a rate of \$15 hour + the cost of parts. Return shipping is not covered for out of warranty items and will be the responsibility of the customer. Items must be picked up or shipped out within 30 days of completion of repairs. If the customer does not pickup merchandise or cover shipping and handling charges for return of such products, the customer agrees to relinquish all rights and titles to and waives all claims against ARI AKON™ for credit related to such products. This form must be filled out and signed by an Adult over the age of 18.

Signature _____

Date ____/____/____

WARRANTY TERMS AND AGREEMENTS

LIMITED 1 year WARRANTY

ARI AKON™ products are warranted for 1 year from the original date of retail purchase. During the warranty period, any part, because of manufacturing defects or workmanship, that fails to function properly under normal use shall be repaired or replaced, at ARI AKON'S™ sole discretion, free of charge. This product must be operated in accordance with the instructions included with the unit.

WHAT IS COVERED

Any parts which are determined to be defective. Labor associated with the warranty repairs. Transportation charges to consumer for repaired product.

WHAT IS NOT COVERED

Malfunctions or damage resulting from misuse, failure to perform normal maintenance (see page 10), tampering, unauthorized repairs, modifications, alterations, abuse, neglect, accident, aftermarket parts and add-ons. Wearable part such as, but not limited to, anodizing, o-rings, cup seal, ball detent, sights, springs, screws, plastic parts, and plastic finishes. Transportation charges to ARI AKON™ for defective product. Use of Locktite® or non-approved lubricant on any ARI AKON™ product will void the warranty.

WARRANTY CLAIMS

USA customers: **You must contact ARI AKON™ at 1-877-4-ARIAKON and obtain a Return Merchandise Authorization Number.** The Repair Authorization Form (see page 19), filled out, and a copy of original purchase receipt must be included with the return.

Package the product carefully using ample padding material to prevent damage in transit and ship it prepaid and insured. We recommend that you ship your return product using a method of shipment that supplies proof of delivery to establish liability. ARI AKON™ is not responsible for items that do not reach us or are lost / damaged in transit.

Please return to:

ARI AKON™

2794 Loker Ave West, Suite #107

Carlsbad CA USA 92008.

RMA#

International Customers: Please return product to your nearest distributor. If you do not know your distributor, please call 760-268-0735 and ask for our International Department for assistance.

IMPLIED WARRANTIES

WE MAKE NO EXPRESS WARRANTIES EXCEPT THOSE STATED IN THIS SECTION. ARI AKON™ MAKES NO REPRESENTATIONS OR WARRANTIES, EITHER EXPRESSED OR IMPLIED, OF ANY KIND WITH RESPECT TO PRODUCTS SOLD, INCLUDING BUT NOT LIMITED TO QUALITY, MERCHANTABILITY AND FITNESS FOR A PARTICULAR PURPOSE. YOU AGREE THAT THE SOLE AND EXCLUSIVE MAXIMUM LIABILITY, TO ARI AKON™ ARISING FROM ANY PRODUCT SOLD, SHALL BE THE PRICE OF THE PRODUCT ORDERED. WE RESERVE THE RIGHT TO MODIFY THIS WARRANTY AT ANY TIME AT OUR SOLE DISCRETION. SOME STATES DO NOT ALLOW LIMITATIONS ON HOW LONG AN IMPLIED WARRANTY LASTS, SO THE ABOVE LIMITATIONS MAY NOT APPLY TO YOU. TO THE EXTENT ANY PROVISIONS OF WARRANTY IS PROHIBITED BY FEDERAL, STATE, OR MUNICIPAL LAW WHICH CANNOT BE PREEMPTED, SHALL NOT BE APPLICABLE. THIS WARRANTY GIVES YOU SPECIFIC LEGAL RIGHTS, AND YOU MAY ALSO HAVE OTHER RIGHTS WHICH VARY FROM STATE TO STATE AND COUNTRY TO COUNTRY.

LIABILITY STATEMENT

ARI AKON™ SHALL NOT BE LIABLE, UNDER ANY CIRCUMSTANCE, FOR CONSEQUENTIAL DAMAGES, INCIDENTAL DAMAGES, OR INCIDENTAL EXPENSES, INCLUDING BUT NOT LIMITED TO, DAMAGE AND LOSS OF PROPERTY, LOSS OF LIFE, PERSONAL INJURY OR ANY OTHER EXPENSE RESULTING FROM THE USE OF THIS WEAPON, INCLUDING THE INTENTIONAL, RECKLESS, NEGLIGENT OR ACCIDENTAL DISCHARGES. SOME STATES DO NOT ALLOW THE EXCLUSION OR LIMITATION OF INCIDENTAL OR CONSEQUENTIAL DAMAGES, SO THE ABOVE LIMITATION OR EXCLUSION MAY NOT APPLY TO YOU.

GOVERNING LAW

THE SALE(S) WILL BE GOVERNED BY THE LAWS OF THE STATE OF CALIFORNIA. VENUE AND JURISDICTION FOR ALL DISPUTES WILL LIE IN SAN DIEGO COUNTY, CALIFORNIA.

TABLE OF CONTENTS

Congratulations on your purchase of an ARI AKON™ paintball marker! As one of the premier manufacturers of quality paintball products we strive to provide you with one of the best paintball markers available. With proper maintenance your marker will provide you with reliable service for many paintball adventures. Please take time to read through the manual thoroughly and become familiar with the parts, operation, and safety precautions before you attempt to load or fire your ARI AKON™ marker.

Warning and Liability Statement.....	4
Be Responsible! Be Safe!	4-5
Specifications and Performance.....	5
Getting Started.....	6
Unloading Your Marker.....	7
Storing Your Marker.....	7
Transporting Your Marker.....	7
Schematic.....	8
Parts List.....	9
Basic Cleaning and Maintenance.....	10
Accessories and Upgrades.....	9
Troubleshooting.....	12-13
Warranty Terms and Agreements.....	14
Repair Authorization Form.....	15

WARNING AND LIABILITY STATEMENT

This marker is classified as a dangerous weapon and is surrendered by ARI AKON™ with the express understanding that the purchaser assumes all liability resulting from unsafe handling, misuse, or any action that constitutes a violation of any applicable laws or regulations. ARI AKON™ assumes no liability for, and shall not be liable for personal injury, loss of property or life resulting from use of this weapon under any circumstances, including but not limited to those resulting from intentional, reckless, negligent, or any other possible accidental discharges.

All information contained in this manual is subject to change without notice. ARI AKON™ reserves the right to make changes and improvements to products without incurring any obligation to incorporate such improvements in products previously sold.

Be responsible! Be safe!

The ownership and use of this marker places the total responsibility of its safe and lawful use upon you. You must observe the same safety precautions as you would any firearm to assure the safety of not only yourself, but everyone around you. The user, at all times, must use caution when using this marker.

- Do not pressurize, load, or fire this marker until you have completely read and understood this manual and are familiar with its operation and safety procedures.
- Handle this marker as if it were loaded at all times.
- Wear paintball approved goggles and full face mask when you are firing your marker, or are within range of anyone else firing their marker. NEVER shoot at someone who is not protected with gear as described.
- Always leave the marker in 'SAFE' mode when not actually in game play.
- Do not carry this paintball marker in public unless it is stored in a paintball case or bag.
- Always make sure your barrel is properly covered with a barrel plug or barrel cover whenever you are not actually in game play.
- Only pressurize and load the marker when you intend to immediately use it. Always unload and remove CO2 cylinder immediately after use for safe storage.

TROUBLESHOOTING

Firing	The marker will not cock	Make sure the marker has been properly reassembled. Refer to "Basic Maintenance and Cleaning" on page 10.
		Make sure the trigger frame (<i>part# 24</i>) is properly attached to the marker. The longer trigger frame screw (<i>part# 23</i>) should be in the front and the shorter in the rear.
	I pull the trigger and nothing happens	Increase the velocity by turning the velocity adjustor (<i>part# 22</i>) clockwise. If the velocity adjustor is too far out the trigger mechanism will not properly engage. If you turn the velocity adjustor all the way in and this still occurs you may need to replace the velocity spring (<i>part# 12</i>)
		Make sure the safety is off. IMPORTANT: Always return the marker to safe mode when not actually in a game or before holstering it.
	Marker sputters or doesn't re-cock	Your CO ₂ cartridge may be low on air and should be reloaded.
		Make sure the bolt (<i>part# 6</i>) and striker (<i>part# 13</i>) are free of debris or broken paint
		Inspect the striker (<i>part #13</i>) o-ring is well oiled and is not damaged. Replace if necessary
	Paintballs Curve	Make sure you are using high quality paintballs that are not old or dirty
	Make sure the barrel is clean. Refer to "Basic Cleaning and Maintenance on page 10.	
More than one paintball comes out at a time	Make sure the ball detent (<i>part #3</i>) is installed properly, and not damaged. Replace if necessary	
	Make sure the paintballs being used are the proper size. They should not roll freely out of the barrel when it is pointed downward	
Breaking paint	Make sure you are using high quality paintballs that are not old, dirty or are misshaped.	
	Make sure the barrel is clean. Refer to "Basic Cleaning and Maintenance on page 10.	
	Make sure the ball detent (<i>part #3</i>) is installed properly, and not damaged. Replace if necessary	

TROUBLESHOOTING

Air Leak	All the air leaks out as soon as I screw down the CO ₂ cap.	Make sure the marker is cocked, and the safety is engaged, before you insert the CO ₂ cartridge.
	Air leaks from where I inset the CO ₂ cartridge	Make sure the CO ₂ cap (<i>part# 8</i>) is tightened all the way down.
		Replace CO ₂ puncture pin (<i>part# 15</i>)
	Air leaks out from the barrel	Make sure your marker has been reassembled properly. Refer to "Basic Cleaning and Maintenance" on page 10.
Replace the cup seal (<i>part# 16</i>)		
Replace the o-rings on the main valve (<i>part #17</i>), and puncture valve (<i>part# 14</i>) using standard CO ₂ bottle o-rings		
		Replace the main valve (<i>part #17</i>)* or puncture valve (<i>part# 14</i>)
Velocity	Velocity is too high	Turn the velocity adjustor (<i>part #22</i>) out, counter-clockwise, until desired velocity is reached
		If the velocity spring (<i>part #12</i>) is new it may need to be broken in; until you are able to achieve the desired velocity*
	Velocity is too low	Turn the velocity adjustor (<i>part# 22</i>) in/clockwise until desired velocity is reached
		Internal parts may be dirty or o-rings may be damaged. Refer to "Basic Cleaning and Maintenance" on page 10
		Check bolt (<i>part #6</i>) to make sure it is not installed upside down. The hole in the center of the bolt should face downward
Firing	There is no air going through my marker	Replace CO ₂ puncture pin (<i>part# 15</i>) If the paintballs barely come out of the barrel refer to "Marker sputters or doesn't re-cock "
	When I fire my marker no paintballs come out.	Make sure there are paintballs in the magazine (<i>part# 1</i>) and it is properly attached to the marker. Make sure the wedge on the magazine plug (<i>part# 2</i>) is in the upward position.

BE RESPONSIBLE! BE SAFE! CONTINUED

- Never point the marker at anything you do not intend to shoot.
- Only use paintball markers where it is legal and/or approved.
- Always keep the muzzle pointed down or in a safe direction.
- Use only .68 caliber paintballs. Never load or attempt to fire any other objects.
- Wear proper attire and avoid exposing any skin when playing the game of paintball.
- Keep exposed skin away from escaping CO₂ gas when installing or removing the cylinder.
- Never look directly into the barrel while it is attached to the marker. accidental discharge into the eyes may cause permanent injury or death.
- Avoid shooting an opponent at point blank (6 feet or less).
- Never disassemble or perform maintenance to the marker while it is pressurized with gas.
- Never shoot at wildlife or any other animals.
- Never shoot your marker at personal property of others.

specifications

Model.....	ARI AKON™
Caliber.....	.68 caliber
Action.....	Semi-automatic (open bolt, blow-back)
Power.....	CO ₂
Barrel length.....	8"
Overall Length.....	13"
Weight	2.2 lbs

PERFORMANCE

Operating a paintball marker below 70°F (21°C) will decrease the number of effective shots. The same is true for operating above 70°F (21°C). Many factors affect velocity and accuracy, including brand of paintball, type of paintball, amount of CO₂ in source, lubrication, barrel condition and temperature.

GETTING STARTED

IMPORTANT: Paintball approved eye and face protection must be worn at all times when handling this or any other marker. Always make sure that when not actively firing the marker in a paintball game, the marker is in "safe" mode and the barrel plug or barrel cover is properly installed.

1) Magazine Clip - Removing and Attaching

To remove the magazine clip (*part# 1*) slide the release lever upward. Hold the release lever in the upward position while sliding the magazine toward the rear of the marker.

To attach the magazine clip (*part# 1*) align the bottom of the magazine with the guide rails on the top of the marker. Slide the magazine forward until the release lever locks into place.

2) Magazine Clip - Loading the Paintballs

First remove the plug (*part# 2*) at the rear of the magazine. Then slide the silver spring rod to the front of the magazine and lock it into place in the groove. Make sure that the inside of the magazine is clean and free of dirt, debris, moisture and paint. Using a 10 round tube, or manually loading the paintballs individually, fill the magazine with ten (10) paintballs. Next replace the plug in the back of the magazine. Lastly, release the spring rod. This will ensure the paintballs feed automatically into the pistol.

NOTE: The magazine plug (part# 2) has an additional feature to prevent paintballs from feeding into the marker. If the wedge on the inside of the plug

is turned down it will stop the paintballs from feeding. Simply turn the wedge up to allow the paintballs to feed into the marker.

3) Air Source Installation

First make sure the marker is in "safe" mode. Next you need to cock the marker by sliding the bolt (*part# 6*) all the way back until it clicks. Then unscrew the CO₂ cap (*part# 8*) counter-clockwise to remove it. Insert a 12 gram CO₂ cartridge into the air chamber. Screw the CO₂ cap back on by turning in clockwise until it is securely tightened.

IMPORTANT: If you do not cock the marker before inserting the CO₂ all the air will escape from the marker.

4) Adjusting the Velocity

To adjust the velocity use the velocity adjuster (*part# 22*) at the rear of the marker. Turning the velocity adjuster in or clockwise will increase the velocity, and adjusting it out or counter-clockwise will lower the velocity. You may need to loosen the locking screw before increasing the velocity.

NOTE: Always check the velocity of you marker using a chronograph at your local paintball field or store.

Additional resources

Remember we are here to help. Below you will find several ways to get additional answers to any questions you may have about your Overlord Pistol.

On our Website: www.ariakon.com
Our website features an extensive support and help section where you will find answers to many common questions.

On our Forum: forum.ariakon.com
Get help from fellow players who also own ARI AKON products on our customer forum. Hundreds of users visit the forum many times per day to discuss ARI AKON products as well as paintball in general. You can also set up games, meet new people, and best of all it's FREE!

On the Phone: 1-877-4-ARI AKON
Our friendly support staff is ready to help you with any questions you may have regarding you new ARI AKON marker. Don't be shy, give us a call.

BASIC CLEANING AND MAINTENANCE

NOTE: Basic maintenance of your ARI AKON™ marker is your responsibility. Your marker will provide you with dependable performance for many games if properly cared for. Not properly maintaining your marker could result in voiding your warranty.

WARNING: Before conducting any maintenance, remove the air source and magazine from your marker. Make sure there are no paintballs left in the marker (Refer to "Unloading Your Marker"). Make sure your marker is in 'SAFE' mode.

Normal maintenance and cleaning will help reduce the majority of any possible complications with the performance of your marker. For best results we recommend cleaning your marker after each day of use. Use a damp towel with water to wipe off paint, oil and debris. (Do not use any cleaning solvents such as 409® or Simple Green®. Use of such products on your marker may cause corrosion and/or damage the internal parts, and may also void your warranty.) When oiling the cleaned parts we recommend using any paintball brand paintball gun oil. (The use of other lubricants such as WD-40®, graphite, and oil designed for actual firearms may cause build up and/or damage the internal parts or seals. Use of such products may also void your warranty.)

In order to help you properly maintain your marker we have created 7 simple steps to cleaning your marker:

1) Remove the retaining clip from the retaining pin (*part# 20*). Then remove the retaining pin from the marker.

Use caution when removing the retaining pin. The velocity lug and spring guide pin will be under pressure from the velocity spring.

2) Pull the bolt (*part# 6*) out from the rear of the marker. This will also cause any remaining internal parts, that need to be cleaned, to be removed from the marker. Clean all internal parts with a soft cloth.

IMPORTANT: Your marker is equipped with a high grade Delrin bolt. Due to nature of this material, broken paint left on the bolt for extended periods of time may be absorbed by the bolt causing it to fail to operate properly. In addition, your Delrin bolt does not need to be oiled. Oil will also prevent the bolt from operating properly. Never store your marker without properly cleaning it first.

3) Use a paintball squeegee, battle swab or soft cloth to clean the upper tube of the marker.

4) Inspect the o-ring on the striker (*part# 13*). If it appears damaged or discolored from paint, replace the o-ring using a standard CO₂ bottle o-ring. We recommend replacing the o-ring on the striker periodically to ensure optimal performance. Oil the striker (*part# 13*) before reassembling the marker.

IMPORTANT: Use only paintball gun oil to lubricate the marker. DO NOT oil the bolt (part# 6).

5) When reassembling the marker, the bolt (*part# 6*) and striker (*part# 13*) must be positioned correctly, with the connecting pin (*part# 7*) inserted properly into the hole on the top of the striker. Holding the pieces together, simultaneously insert the parts into the rear of the marker with the o-ring end of the striker going in first.

Continue to push the parts all the way in. You will need to pull the trigger a few times while pushing the parts in for the striker to be able to pass over the sear (*part# 19*).

6) Next insert the striker cushion (*part# 11*) into the lower tube. Then insert the velocity spring (*part# 12*) into the lower tube, followed by the velocity spring guide pin (*part# 10*).

7) Lastly, push the velocity lug (*part# 21*) into the marker until the groove lines up with the hole for the retaining pin. Hold the velocity lug in place while inserting the retaining pin (*part# 20*). Reinsert the retaining clip.

UNLOADING YOUR MARKER

IMPORTANT: Paintball approved eye and face protection should be worn when operating any paintball product. Make sure your barrel plug, or barrel cover, is installed properly and always keep your marker pointed in a safe direction away from others.

1) When finished using the marker make sure there are no paintballs or air left in the marker. To do so, point the marker in a safe direction, away from others, take the marker out of "safe" mode, and fire the marker until all the air is gone. Return the marker to "safe" mode. To ensure there are no paintballs left in the marker remove the magazine and turn the pistol upside-down. Make sure there are no paintballs left inside the magazine before reattaching. You may then safely remove the CO₂ cartridge.

Storing your marker

NOTE: Proper storage of your ARI AKON™ paintball marker can help cut down on the maintenance needed when bringing the marker back out to play.

- 1) Before storing, make sure there are no paintballs or air left in the marker. Do not store the marker with a CO₂ cartridge in the air chamber. (Refer to "Unloading Your Marker").
- 2) Clean and oil necessary parts before storing (Refer to "Basic Cleaning and Maintenance"). You should store your marker in a dry area.
IMPORTANT: Do not oil the bolt (part# 6) as it is self-lubricating. Failure to clean your marker may void the warranty.
- 3) When removing your marker from storage you should re-oil the striker.

Transporting your marker

Observe all local, state and federal laws concerning the transportation of paintball markers. For information concerning any of the laws in your area, contact your nearby law enforcement agency.

NEVER CARRY YOUR MARKER UNCASSED WHEN NOT ON A PLAYING FIELD. THE NON-PLAYING PUBLIC AND LAW ENFORCEMENT PERSONNEL MAY NOT BE ABLE TO DISTINGUISH BETWEEN A PAINT MARKING DEVICE AND FIREARM. FOR YOUR OWN SAFETY AND TO PROTECT THE IMAGE OF THE SPORT, ALWAYS CARRY YOUR MARKER IN A SUITABLE CASE OR THE BOX IT WAS PURCHASED IN.

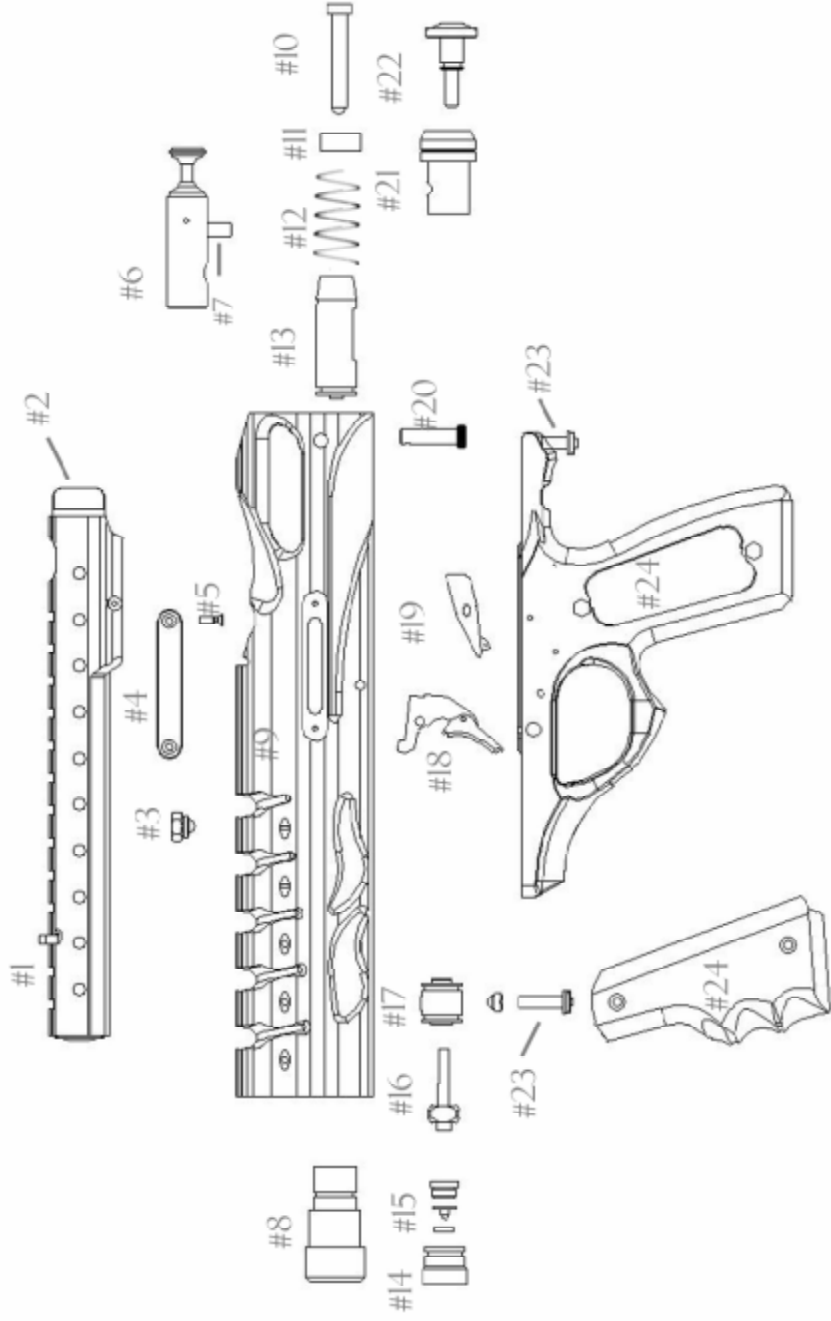

Overlord parts list

- | | |
|---------------------------------|---|
| 1. Magazine | 13. Striker |
| 2. Magazine Plug | 14. Puncture Valve |
| 3. Ball Detent | 15. Puncture Pin |
| 4. Air Passage Cover | 16. Cup Seal |
| 5. Air Passage Cover Screws (2) | 17. Main Valve |
| 6. Bolt | 18. Trigger |
| 7. Connector Pin | 19. Sear |
| 8. CO ₂ Cap | 20. Retaining Lug |
| 9. Body | 21. Velocity Lug |
| 10. Velocity Spring Guide Pin | 22. Velocity Adjustor |
| 11. Striker Cushion | 23. Trigger Frame Screws (2) |
| 12. Velocity Spring | 24. Trigger Frame |
| | 25. Cup Seal Return Spring (not pictured) |