



ETEK
OPERATORS MANUAL

WARNING**ADHERE STRICTLY TO THESE AND ALL OTHER SAFETY INSTRUCTIONS AND GUIDELINES!**

- 01. PLEASE READ AND UNDERSTAND ALL INSTRUCTION MANUALS BEFORE USE.**
- 02. The Eclipse Etek3 is not a toy. PAINTBALL SAFETY RULES MUST BE FOLLOWED AT ALL TIMES.**
- 03. Careless or improper use, including failure to follow instructions and warnings within this User Manual and attached to the Etek3 could cause death or serious injury.**
- 04. Do not remove or deface any warnings attached to the Etek3.**
- 05. Paintball industry standard eye/face/ear and head protection designed specifically to stop paintballs and meeting ASTM standard F1776 (USA) or CE standard (Europe) must be worn by user and any person within range. Proper protection must be worn during assembly, cleaning and maintenance.**
- 06. Never shoot at a person who is not wearing proper protection.**
- 07. Never look directly into the barrel of the marker. Accidental discharge into the eyes may cause permanent injury or death. Never look into the barrel or breech area of the Etek3 whilst the marker is switched on and able to fire.**
- 08. Keep the Etek3 switched off until ready to shoot.**
- 09. Treat every marker as if it is loaded and ready to fire.**
- 10. The electronic on/off is the markers safety, always switch off the marker when not in use.**
- 11. Always fit a barrel-blocking device to the Etek3 when not in use.**
- 12. Always remove all paintballs from the Etek3 when not in use on the field of play.**
- 13. Never point the Etek3 at anything you do not intend to shoot.**
- 14. Do not shoot at persons at close range.**
- 15. Do not field strip or remove any parts while the marker is pressurised.**
- 16. Do not fire the Etek3 without the bolt in the breech, as high-pressure gas will be emitted.**
- 17. Do not fire the Etek3 without the bolt pin locked securely in place.**
- 18. Never put your finger or any foreign objects into the paintball feed tube of the Etek3.**
- 19. Never allow pressurised gas to come into contact with any part of your body.**
- 20. Always remove the first stage regulator and relieve all residual gas pressure from the Etek3 before disassembly.**
- 21. Always remove the first stage regulator and relieve all residual gas pressure from the Etek3 for transport and storage.**
- 22. Always follow guidelines given with your first stage regulator for safe transportation and storage.**
- 23. Always store the Etek3 in a secure place.**

WARNING

ADHERE STRICTLY TO THESE AND ALL OTHER SAFETY INSTRUCTIONS AND GUIDELINES!

- Persons under 18 years of age must have adult supervision when using or handling the Etek3.
- Observe all local and national laws, regulations and guidelines.
- Use only professional paintball fields where codes of safety are strictly enforced.
- Use compressed air/nitrogen only. **DO NOT** use any other compressed gas or pressurised liquid including CO₂.
- Always follow instructions, warnings and guidelines given with any first stage regulator you use with the Etek3.
- Use 0.68 calibre paintballs only.
- Always measure your markers velocity before playing paintball, using a suitable chronograph.
- Never shoot at velocities in excess of 300 feet (91.44 meters) per second, or at velocities greater than local or national laws allow.
- Any installations, modifications or repairs should be carried out by a qualified individual at a licensed and insured paintball facility.



THIS USERS MANUAL IS IN ENGLISH.

It contains important safety guidelines and Instructions. Should you be unsure at any stage, or unable to understand the contents within this manual you must seek expert advice.



LE MODE D'EMPLOI EST EN ANGLAIS.

Il contient des instructions et mesures de sécurité importantes. En cas de doute, ou s'il vous est impossible de comprendre le contenu du mode d'emploi, demandez conseil à un expert.



ESTE MANUAL DE USUARIOS (OPERARIOS) USARIOS ESTÁ EN INGLÉS.

Contiene importantes normas de seguridad e instrucciones. Si no está seguro de algún punto o no entiende los contenidos de este manual debe consultar con un experto.



DIESE BEDIENUNGS - UND BENUTZERANLEITUNG IST IN ENGLISCH.

Sie enthält wichtige Sicherheitsrichtlinien und -bestimmungen. Sollten Sie sich in irgendeiner Weise unsicher sein, oder den Inhalte dies Heftes nicht verstehen, lassen Sie sich bitte von einen Experten beraten.

NOTE: THIS USER MANUAL MUST ACCOMPANY THE PRODUCT IN THE EVENT OF RESALE OR NEW OWNERSHIP. SHOULD YOU BE UNSURE AT ANY STAGE YOU MUST SEEK EXPERT ADVICE! (SEE SERVICE CENTRES PAGE 80-81)

QUICK GUIDE

CONTENTS
QUICK SET-UP
ORIENTATION
USING YOUR ETEK3
ADVANCED SET-UP
EMORTAL BOARD
MAINTENANCE
UPGRADING
FAULT FINDING
SERVICE CENTRES
PARTS LIST
SPARES & ACCESSORIES
INDEX

WARNING



QUICK SET-UP

Details on how to get up and running quickly with your Etek3. This section is essential reading for everyone.

- SWITCHING ON THE ETEK3.....6
- SWITCHING OFF THE ETEK3.....6
- FIRING THE ETEK3.....6
- THE ETEK3 CIRCUIT BOARD.....6
- SWITCHING ON THE ETEK3 EMORTAL BOARD.....7
- SWITCHING OFF THE ETEK3 EMORTAL BOARD.....7
- FIRING THE ETEK3.....7
- THE ETEK3 EMORTAL BOARD.....7
- USING THE BREAK BEAM SENSOR SYSTEM.....8
- USING THE EMORTAL BOARD BREAK BEAM SENSOR SYSTEM.....9
- INSTALLING A 9V BATTERY.....10

ORIENTATION

Names the component parts of the Etek3 Marker. This section is essential reading for everyone.

- THE ETEK3 LT.....11
- THE ETEK3 AM.....12
- THE ETEK3 EMORTAL BOARD.....12
- KNOW YOUR ETEK3.....13
- ETEK3 2-PIECE BARREL.....14
- INLINE REGULATOR.....15
- LOW PRESSURE REGULATOR.....16
- ETEK3 SOLENOID ASSEMBLY.....17
- THE ETEK3 NAVIGATION CONSOLE.....18
- OPERATIONAL OVERVIEW.....19

USING THE ETEK3

More detailed information on how to use and interact with the Etek3 via its user interface.

- SETTING UP THE ETEK3.....20
- INSTALLING A PRESET AIR SYSTEM.....20
- T-SLOT MOUNTING SYSTEM.....21
- MACROLINE HOSE AND ELBOWS.....21
- ATTACHING A LOADER.....22
- SETTING THE TRIGGER.....23
- ADJUSTING THE VELOCITY.....24
- ADJUSTING THE LPR PRESSURE.....24

- THE TOURNAMENT LOCK.....25
- UNDERSTANDING THE BBSS OPERATION.....26
- THE BATTERY LEVEL INDICATOR.....26

ADVANCED SET-UP

In depth information on setting up the Etek3.

- THE SET UP MODE.....27
- MODIFYING A PARAMETER.....27
- SET UP PARAMETERS.....28
- THE FIRING MODE PARAMETER.....28
- THE MAXIMUM ROF WITH BBSS ON (CAPPED MODES).....28
- THE MAXIMUM ROF WITH BBSS OFF.....28
- RAMP KICK-IN RATE (RAMP ONLY).....29
- RAMP RESTART TIME (RAMP ONLY).....29
- SET UP PARAMETERS TABLE.....30
- DWELL.....31
- DEBOUNCE.....31
- THE BALL DETECTION TIME.....31
- THE RESET PARAMETER.....31

THE EMORTAL BOARD

In depth information covering all aspects of the Etek3 Emortal Circuit Board.

- THE EMORTAL BOARD NAVIGATION BOARD.....32
- USER INTERFACE.....33
- SWITCHING ON.....33
- RUN SCREEN LAYOUT.....33
- UNDERSTANDING THE BREAK BEAM SENSOR SYSTEM.....34
- UNDERSTANDING THE TRIGGER DETECTION INDICATOR.....34
- UNDERSTANDING THE LOCK INDICATOR.....35
- UNDERSTANDING THE BATTERY LEVEL INDICATOR.....35
- THE GAME TIMER.....35
- THE SHOT COUNTER.....35
- THE ACTUAL RATE OF FIRE.....36
- THE PEAK RATE OF FIRE.....36
- THE MENU SYSTEM.....36
- THE MENU TREE.....37
- ACCESSING THE MENU SYSTEM.....41

MOVING AROUND THE MENUS.....	41
ALTERING PARAMETERS.....	41
THE MAIN MENU.....	42
DISPLAY -The Display Parameter.....	42
TIMER -The Game Timer Menu.....	42
GAME -The Game Time Parameter.....	42
START -The Timer Start Parameter.....	42
THE SET-UP MENU.....	43
LOCK -The Tournament Lock Parameter.....	44
PRESET -The Preset Menu.....	44
LOAD -The Load Preset Parameter.....	44
SAVE -The Save Preset Parameter.....	45
MODE -The Firing Mode Parameter.....	45
ROF CAP -Rate of Fire Cap Parameter.....	46
MAX ROF -Maximum Rate of Fire Parameter.....	46
OFF ROF -Rate of Fire With BBSS Off Parameter.....	47
RMP SET -The Ramp Settings Menu.....	47
TYPE -The Ramp Type Parameter.....	47
RATE -The Linear Ramp Rate Parameter.....	48
PULL NO -The Ramp Start Parameter.....	48
KICK IN -The Ramp Kick-In Parameter.....	48
SUSTAIN -The Sustain Rate Parameter.....	48
RESTART -The Ramp Restart Parameter.....	48
TIMING -The Timing Menu.....	49
DWELL -The Dwell parameter.....	49
FSD COMP -The First Shot Drop-off Compensation Parameter.....	49
FSD DLY -The First Shot Drop-off Delay Parameter.....	49
LIGHT -The Light Parameter.....	49
SLEEP -The Sleep Parameter.....	49
FILTER -The Filter Menu.....	50
DBOUNCE -The Debounce Parameter.....	50
EMPTY -The Breech Empty Time Parameter.....	50
FULL -The Breech Full Time Parameter.....	50
PULL TM -The Trigger Pull Time Parameter.....	50
REL TM -The Trigger Release Time Parameter.....	50
TRAININ -The Training Parameter.....	51

MAINTENANCE

A guide to performing routine maintenance.

CLEANING THE BREAK BEAM SENSOR SYSTEM.....	52
---	-----------

CLEANING THE INLINE REGULATOR.....	54
CLEANING THE LOW PRESSURE REGULATOR.....	56
MAINTAINING THE RAMMER.....	58
CLEANING AND LUBRICATING THE BOLT.....	60
REMOVING AND ATTACHING THE FRAME.....	61
THE ETEK3 TRIGGER ASSEMBLY.....	63
THE ETEK3 SOLENOID ASSEMBLY.....	65
MAINTAINING THE VALVE ASSEMBLY.....	67
THE ETEK3 ON/OFF PURGE SYSTEM.....	70

UPGRADING

Information on how to upgrade your Etek3 with Official Eclipse upgrade components.

INSTALLING THE LT UPGRADE KIT.....	72
INSTALLING THE ETEK3 EMORTAL BOARD.....	75

FAULT FINDING.....77

Information on how to resolve any problems that might arise with your Etek3.

SERVICE CENTRES80

Information on the location of your nearest Etek3 Service Centre.

PART LISTS83

Tables of components that make up the Etek3.

WARRANTY CARD

Tear-out product registration card to be completed and returned. Alternatively register online at www.planeteclipse.com

SPARES & ACCESSORIES86

Available upgrade / repair kits for your Etek3.

INDEX.....88

Etek3 Manual Index

SECTION HEADERS OF THIS MANUAL ARE PRINTED ■. THESE PAGES CONTAIN INFORMATION REGARDING THE EMORTAL BOARD UPGRADE.

QUICK GUIDE

CONTENTS
QUICK SET-UP
ORIENTATION
USING YOUR ETEK3
ADVANCED SET-UP
EMORTAL BOARD
MAINTENANCE
UPGRADING
FAULT FINDING
SERVICE CENTERS
PARTS LIST
SPARES & ACCESSORIES
INDEX

CONTENTS

SWITCHING ON THE ETEK3

At the rear of the grip frame is the Navigation Console. Press and hold the Select button  (SEE FIGURE 1.1). Release the Select button  when the LEDs light up and your Etek3 will begin its power up sequence.¹

SWITCHING OFF THE ETEK3

Press and hold the Select button . Release the Select button  when all three of the LEDs on the Navigation Console turn red. The LEDs will extinguish one by one and the Etek3 will turn off.

FIRING THE ETEK3

If the Break Beam Sensor System (BBSS) is disabled, pull the trigger to fire the Etek3. If the Break Beam Sensor System is enabled and there is a paintball in the breech, pulling the trigger will also fire the Etek3. The entire firing sequence is controlled electronically by the Etek3 circuit board and solenoid, enabling any user to achieve high rates of fire easily.

THE ETEK3 LED CIRCUIT BOARD

There are three sockets on the Etek3 circuit board, the BBSS connector (A), the Etek3 solenoid connector (B) and the micro-switch connector (C) (SEE FIGURE 1.2).



FIG 1.1





FIG 1.2

SWITCHING ON THE ETEK3 EMORTAL BOARD

To switch on the Etek3 press and hold the  button until the screen lights up and the Emortal board begins its power up sequence (FIGURE 2.1).^{1,2}

SWITCHING OFF THE ETEK3 EMORTAL BOARD

Press and hold the  button until the display shows **TURN OFF**. Release the  button and re-press it to turn off the Etek3.

FIRING THE ETEK3

If the Break Beam Sensor System (BBSS) is disabled, pull the trigger to fire the Etek3. If the Break Beam Sensor System is enabled and there is a paintball in the breech, pulling the trigger will also fire the Etek3. The entire firing sequence is controlled electronically by the Etek3 Emortal board and solenoid, enabling any user to achieve high rates of fire easily.

THE ETEK3 EMORTAL BOARD

There are three sockets on the Etek3 circuit board, the BBSS connector (A), the Etek3 solenoid connector (B) and the micro-switch connector (C) (SEE FIGURE 2.2).

¹ When the Etek3 is turned on, the Break Beam Sensor System is automatically enabled.

² By continuing holding down the  button when turning on the Emortal board the software version number will be displayed.

⚠ WARNING //

WARNING: THE BACKLIGHT ON THE LCD DISPLAY TURNS OFF AFTER A PERIOD OF TIME. WHEN THIS HAPPENS THE MARKER IS STILL ON AND ABLE TO FIRE. SEE PAGE 49 ON ADJUSTING THE BACKLIGHT



FIG 2.1



FIG 2.2

QUICK GUIDE

CONTENTS

QUICK SET-UP

ORIENTATION

USING YOUR ETEK3

ADVANCED SET-UP

EMORTAL BOARD

MAINTENANCE

UPGRADING

FAULT FINDING

SERVICE CENTERS

PARTS LIST

SPARES & ACCESSORIES

INDEX

QUICK SET-UP



USING THE BREAK BEAM SENSOR SYSTEM

When the Etek3 is powered up, the Break Beam Sensor System (BBSS) is automatically enabled.

To switch off the Break Beam Sensor System, push and hold the Select button  for 0.5 seconds. The 'E' on the Navigation Console will flash purple indicating that the Break Beam Sensor System has been disabled.

To switch on the Break Beam Sensor System, push and hold the Select button  for 0.5 seconds. The 'E' on the Navigation Console will flash either yellow (no ball detected) or light blue (ball detected) indicating that the Break Beam Sensor System has been enabled.

Additional features of the Etek3 Break Beam Sensor System are covered in full in the 'Understanding the BBSS Operation' section on Page 26 of this User Manual.



YELLOW LIGHT - NO BALL DETECTED



PURPLE LIGHT - BBSS DISABLED







LIGHT BLUE LIGHT - BALL DETECTED



USING THE EMORTAL BOARD BREAK BEAM SENSOR SYSTEM

The Break Beam Sensor System (BBSS) is used to detect when a paintball is ready to fire from the Etek3. If no paintball is ready then the BBSS will inhibit the Etek3 from firing. This prevents the Etek3 from 'chopping' paintballs that are not fully loaded into the marker.

To switch off the Break Beam Sensor System, press and hold the  button for 0.5 second (SEE FIGURE 3.1).

The break beam sensor system indicator on the top right of the LCD will change from  (enabled) to  (disabled).

To switch the Break Beam Sensor System back on, press and hold the  button for one second. The indicator will change back to .

When the Break Beam Sensor System is enabled, the indicator will change depending on whether the system has detected a ball or not. When no ball has been detected the indicator looks like this  when a ball has been detected the indicator changes to look like this .

Additional features of the Emortal Board's Break Beam Sensor System are covered in full on page 34 of this user manual.



FIG 3.1

QUICK GUIDE

CONTENTS

QUICK SET-UP

ORIENTATION

USING YOUR ETEK3

ADVANCED SET-UP

EMORTAL BOARD

MAINTENANCE

UPGRADING

FAULT FINDING

SERVICE CENTERS

PARTS LIST

SPARES & ACCESSORIES

INDEX

QUICK SET-UP

INSTALLING A 9V BATTERY

Ensure that the Etek3 is switched off. Place the marker on a flat surface in front of you with the feed tube furthest away from you and the barrel pointing to the right.

Using a 5/64" (2mm) hex key, remove the three countersunk screws that holds the rubber grip onto the grip frame. Peel the rubber grip to the right to expose the electronics within the grip frame.

If present remove the existing 9 volt battery by sliding your thumb into the recess provided below the battery and lever the battery gently out of the frame (**SEE FIGURE 4.1**).

On top of the battery you will see the battery connector and wire that is used to connect the battery to the circuit board. Gently separate the battery connector from the battery, so that the existing battery can be disposed of accordingly and taking a new 9 volt Alkaline battery (type PP3, 6LR61, MN1064)¹ connect it to the battery connector (**SEE FIGURE 4.2**).

The battery will only connect to the battery connector one way. If you are unsure of how to install a new battery please contact your nearest Eclipse Service Centre.

Ensure that all of the wires are within the recess of the frame and not trapped in micro-switch, then replace the rubber grip and tighten the countersunk grip screws using the 5/64"¹⁹ (2mm) hex key.

DO NOT OVER-TIGHTEN THE SCREWS.

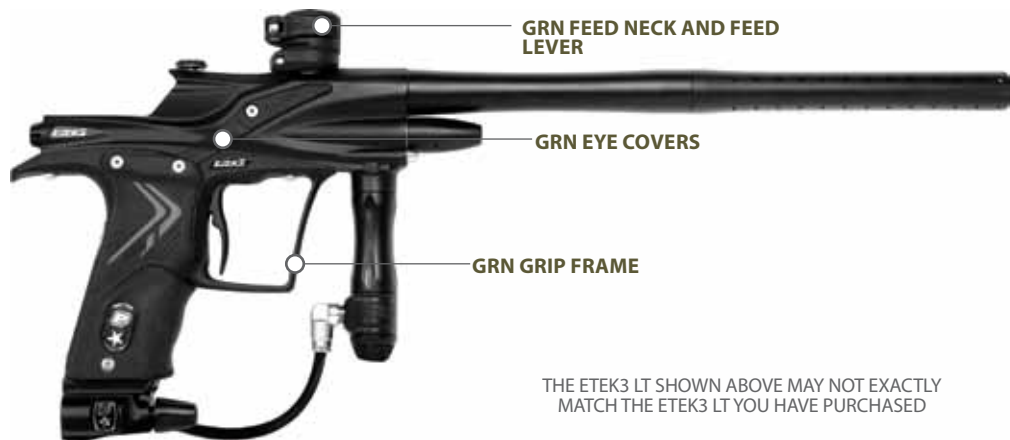

FIG 4.1



FIG 4.2

THE ETEK3 LT



GRN FEED NECK AND FEED
LEVER

GRN EYE COVERS

GRN GRIP FRAME

THE ETEK3 LT SHOWN ABOVE MAY NOT EXACTLY
MATCH THE ETEK3 LT YOU HAVE PURCHASED

Your Eclipse Etek3 LT comes standard with:

GRN (Glass Reinforced Nylon) composite grip frame
GRN composite eye covers
GRN composite feedneck and feed lever

These components are upgradable to the same spec level as the Etek3 AM by installing the Etek3 LT Upgrade Kit which contains:

Aluminium grip frame
Aluminium eye covers
Aluminium feedneck and feed lever

Instructions on installing these components can be found on pages 72-74

All other parts of the Etek3 LT (other than the GRN parts) are manufactured from exactly the same materials and finishes you will find on the Etek3 AM.

QUICK GUIDE

CONTENTS

QUICK SET-UP

ORIENTATION

USING YOUR ETEK3

ADVANCED SET-UP

EMORTAL BOARD

MAINTENANCE

UPGRADING

FAULT FINDING

SERVICE CENTERS

PARTS LIST

SPARES & ACCESSORIES

INDEX

ORIENTATION

THE ETEK3 AM



THE ETEK3 AM SHOWN ABOVE MAY NOT EXACTLY
MATCH THE ETEK3 AM YOU HAVE PURCHASED

The Eclipse Etek3 AM is intrinsically identical to the Etek3 LT but comes standard with an 'ALL METAL' construction. All the parts on the AM are made from the same materials and with the same finishes found on the Ego and Geo range of markers.

The metal frame of the Etek3 AM or upgraded Etek3 LT (upgraded with Etek3 LT upgrade kit) allow for the installation of the Etek3 Emortal Board. This is a fully functional LCD board with a similar menu system to that of the Ego and Geo markers.

Instructions on using the Emortal board can be found starting on pages 32-51. this is essential reading for users with the Emortal board fitted. Users with an Emortal Board fitted will have a console in the back of their Etek3 frame like the one shown opposite.

THE ETEK3 EMORTAL BOARD



KNOW YOUR ETEK3

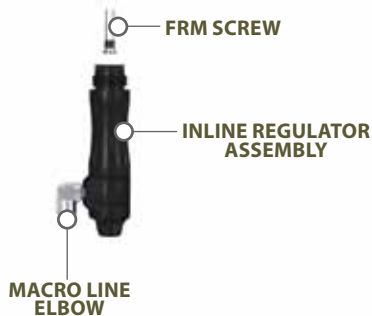
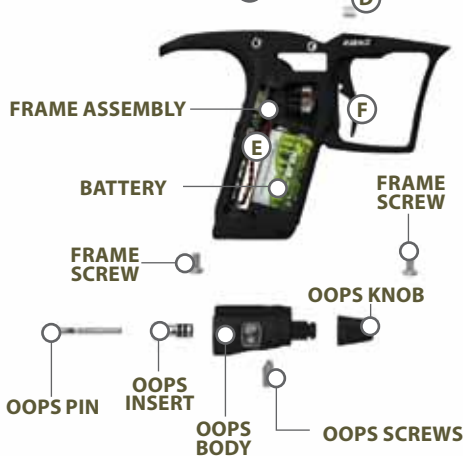
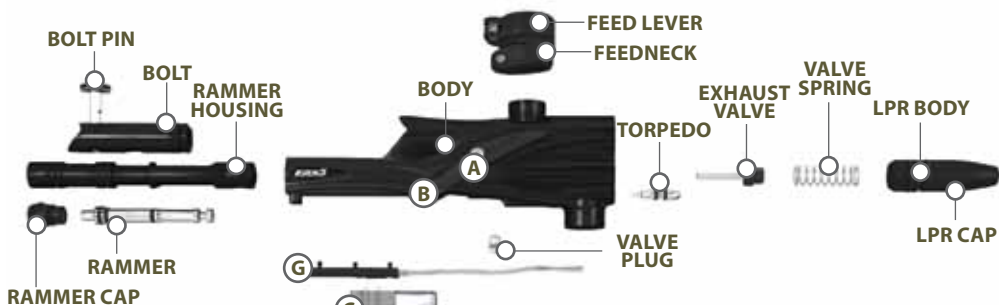

- EYE COVER SCREW (A)
- EYE COVER (B)
- SOLENOID ASSEMBLY (C)
- TRIGGER RETAINING CLIP (D)
- CIRCUIT BOARD (E)
- TRIGGER (F)
- SOLENOID MANIFOLD ASSEMBLY (G)

QUICK GUIDE

CONTENTS

QUICK SET-UP

ORIENTATION

USING YOUR ETEK3

ADVANCED SET-UP

EMORTAL BOARD

MAINTENANCE

UPGRADING

FAULT FINDING

SERVICE CENTERS

PARTS LIST

SPARES & ACCESSORIES

INDEX

ORIENTATION



ETEK3 2-PIECE BARREL

THE BORE SIZE OF YOUR BARREL MAY VARY ACCORDING TO THE MODEL OF ETEK3 YOU HAVE

Your Eclipse Etek3 comes as standard with a 14 inch 2-piece barrel.

The barrel screws into the body of the Etek3 using a right hand thread meaning that if you hold the Etek3 pointing away from you the barrel screws into the body in a counter-clockwise direction.

The barrel comprises of two parts, a barrel back **A** and a barrel front **B**. The two parts are joined together with a left hand thread meaning that if you hold the barrel, with the back nearest you, the front unscrews in a counter-clockwise direction. The bore size of the barrel back is engraved at the end of the barrel back **C**.

On the barrel back there is a 016 NBR 70 o-ring **D** which prevents the barrel from vibrating loose from the Etek3 body when the marker is fired. There is also a 015 NBR 70 o-ring on the barrel front **E** helps with alignment when the two sections are screwed together.

Replace and lubricate these o-rings with Eclipse Grease as necessary.



⚠ WARNING //

WARNING: THE ETEK3 WILL ONLY ACCEPT COCKER THREADED BARRELS (SUCH AS THE ECLIPSE SHAFT 3 BARREL). DO NOT USE ANY OTHER TYPE OF BARREL THREAD.

INLINE REGULATOR

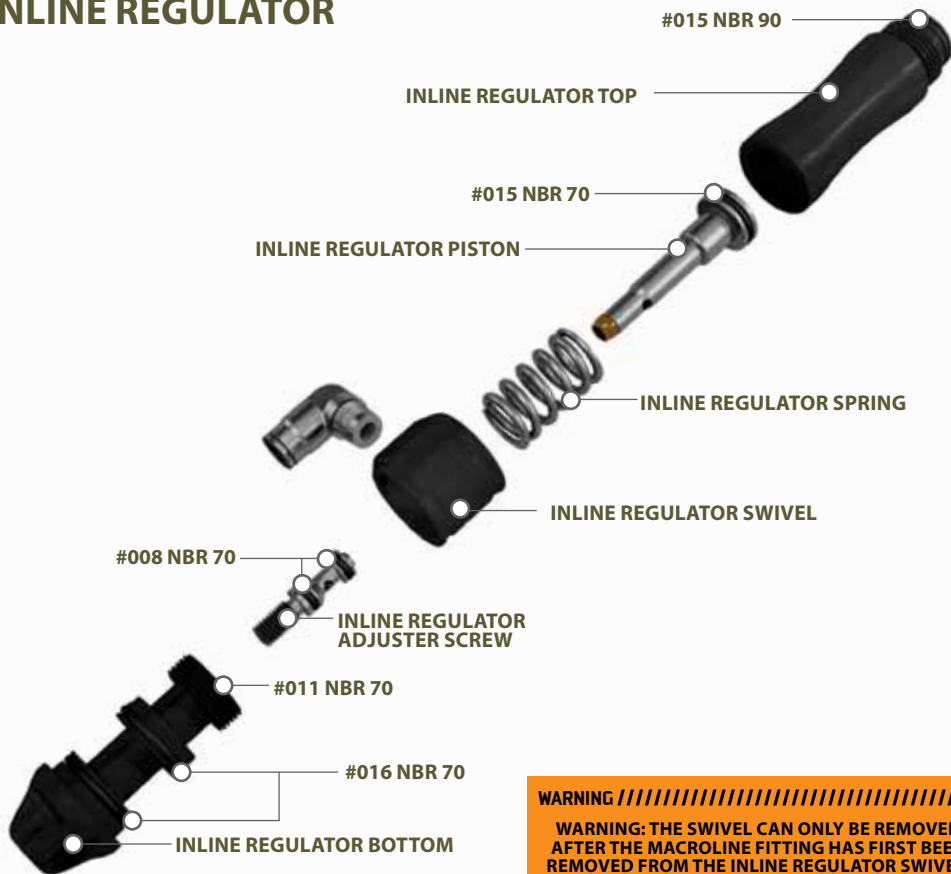

WARNING //

WARNING: THE SWIVEL CAN ONLY BE REMOVED AFTER THE MACROLINE FITTING HAS FIRST BEEN REMOVED FROM THE INLINE REGULATOR SWIVEL.

QUICK GUIDE

CONTENTS
QUICK SET-UP
ORIENTATION
USING YOUR ETEK3
ADVANCED SET-UP
EMORTAL BOARD
MAINTENANCE
UPGRADING
FAULT FINDING
SERVICE CENTERS
PARTS LIST
SPARES & ACCESSORIES
INDEX

ORIENTATION

LOW PRESSURE REGULATOR

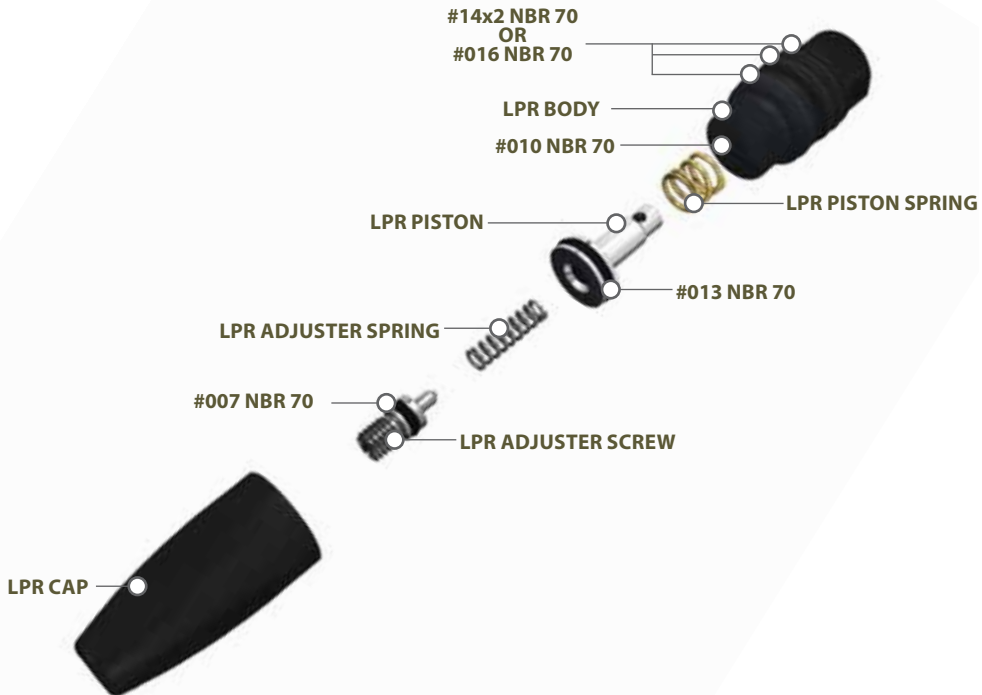

ETEK3 SOLENOID ASSEMBLY

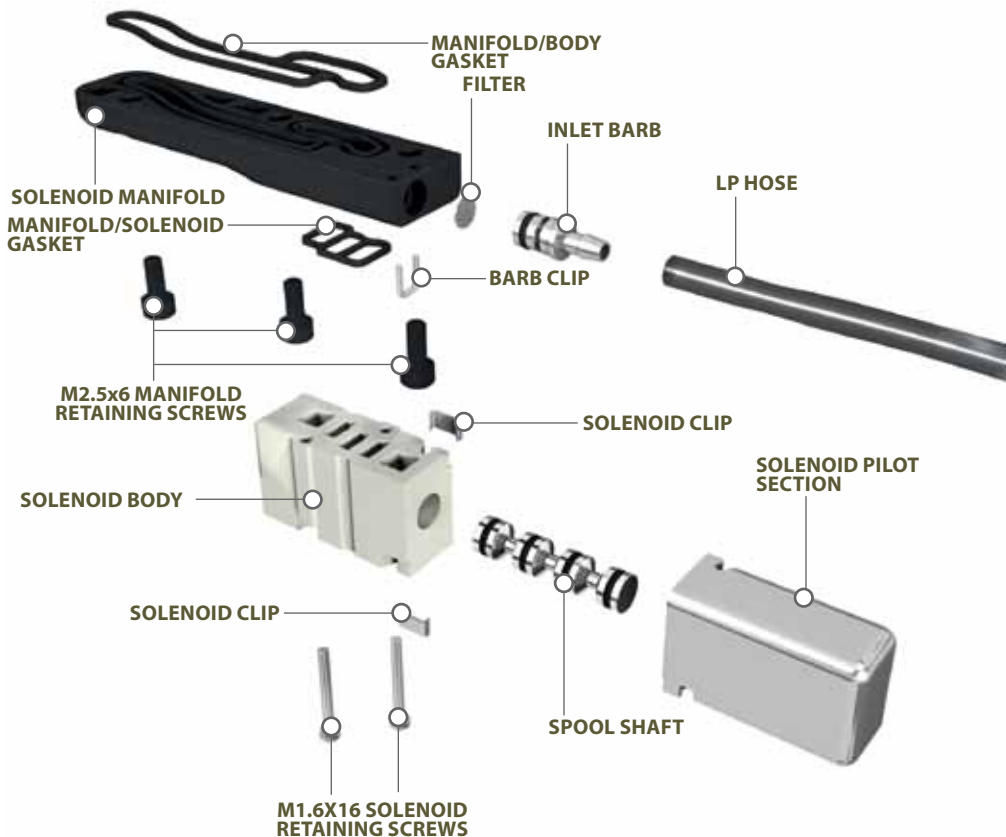

QUICK GUIDE

CONTENTS

QUICK SET-UP

ORIENTATION

USING YOUR ETEK3

ADVANCED SET-UP

EMORTAL BOARD

MAINTENANCE

UPGRADING

FAULT FINDING

SERVICE CENTERS

PARTS LIST

SPARES & ACCESSORIES

INDEX

ORIENTATION

THE ETEK3 NAVIGATION CONSOLE

The Etek3 utilises multi coloured LEDs to display all of the information that the user requires via the Etek3 Navigation Console.

Each area of the Navigation Console is used to perform different functions and display different information as outlined below:

- The Select button  is used to:
- Switch the Etek3 on and off.
 - Switch the BBSS (eye system) on and off.
 - To scroll through parameters and edit parameters.

- The “E” on the Navigation Console is used to:
- Display the status of the BBSS (eye system).
 - Display the value of a parameter in tens (10 - 90)

- The “G” on the Navigation Console is used to:
- Display the value of a parameter in units (0 - 9)
 - Display the status of the battery.

- The “O” on the Navigation Console is used to:
- Display the value of a parameter in tenths (0.0 - 0.9)

- As a combined unit the “E”, “G” and “O” are also used to:
- Display power up and power down status.
 - Display tournament lock status.
 - Display that factory settings have been restored
 - To confirm whether a parameter value has been accepted or rejected.

ETEK3 LT

ETEK3 AM

SELECT
BUTTON



OPERATIONAL OVERVIEW

Below is a brief overview of what happens during the Etek3 firing cycle. The location of parts discussed in the text below can be found on page 82-85.

Assuming the Etek3 is gassed up and turned on, **FIGURE 5.1** shows the marker in its idle position. The rammer is held in its rear position with pressurised air from the LPR directed through the solenoid to the front of the rammer. The valve chamber is full of pressurised air from the inline regulator.

Providing a ball is in the breach, when the trigger is pulled, a signal is sent to the solenoid which redirects the supply of air from the front of the rammer to the rear, which pushes the rammer and bolt forward toward the valve (**FIGURE 5.2**). As this happens the air in front of the rammer is vented out through an exhaust port in the solenoid manifold.

The rammer makes contact with the valve stem and continues to be pushed forward, now pushing the valve forward with it. This breaks the valve seal allowing pressurised air to flow up through the valve and into the bolt and vent down the barrel, propelling a ball. (**FIGURE 5.3**)

The time that the rammer is held in this forward position is dependant on the *DWELL* parameter. The longer the dwell time the longer the Etek3 vents gas down the barrel. When this dwell time has elapsed, the solenoid redirects the supply of air from the back of the rammer to the front, pushing the rammer and bolt back to the rear position. This loss of forward force allows the valve to re-seal and the valve chamber is re-pressurised. As the rammer moves back air behind it is vented through an exhaust port in the solenoid manifold (**FIGURE 5.4**).

The Etek3 has now completed one cycle and is ready to fire again.



QUICK GUIDE

CONTENTS

QUICK SET-UP

ORIENTATION

USING YOUR ETEK3

ADVANCED SET-UP

EMORTAL BOARD

MAINTENANCE

UPGRADING

FAULT FINDING

SERVICE CENTERS

PARTS LIST

SPARES & ACCESSORIES

INDEX

ORIENTATION



SETTING UP YOUR ETEK3

Before you can begin to use your Etek3, you will need to attach an air system and a paintball loader.

INSTALLING A PRESET AIR SYSTEM

Every Etek3 comes complete with an Eclipse On/Off Purge System (OOPS) which provides a direct connection for a preset air system. Before screwing the air system into the OOPS ensure that the On/Off knob is wound out approximately half way (SEE FIGURE 6.1). Be careful not to unscrew the On/Off knob too far as it will come completely off the OOPS. If this happens, replace the On/Off knob by screwing it back onto the OOPS body in a clockwise direction.

Screw the preset air system¹ into the OOPS (SEE FIGURE 6.2) so that the bottle screws in all the way and is tight. Slowly turn the On/Off knob in a clockwise direction allowing the OOPS to depress the pin of the preset air system causing the Etek3 to become pressurised, providing that there is sufficient air in your tank (SEE FIGURE 6.3).

You have now installed a preset air system onto your Etek3.

¹We recommend using a preset air system with a high pressure output to achieve optimum performance from the Etek3, however most good quality Low pressure output systems will also work on the Etek3.

⚠ WARNING //

WARNING: MAKE SURE THE MARKER IS TURNED OFF AND THAT NO PAINTBALLS ARE IN THE MARKER OR LOADER BEFORE INSTALLING AN AIR SYSTEM.

⚠ WARNING //

WARNING: ALWAYS RELIEVE ALL RESIDUAL GAS PRESSURE FROM THE ETEK3 BEFORE UNSCREWING THE PRESET AIR SYSTEM.

⚠ WARNING //

WARNING: THE ETEK3 CANNOT BE USED WITH CO2, IT CAN ONLY BE POWERED BY COMPRESSED AIR OR NITROGEN.



FIG 6.1



FIG 6.2



FIG 6.3

T-SLOT MOUNTING SYSTEM

The Etek3 utilises a T-slot arrangement to mount the OOPS to the bottom of the frame. The T-slot is an improvement over the dovetail mounting system found on most paintball markers, and is much more able to withstand the rigours of modern tournament paintball.



MACROLINE HOISING AND ELBOWS

To aid the longevity of your macroline hosing, it is very important to remove it from (and install it back into) the fittings in the correct manner:

Pull back the collet section of the macroline fitting and keep the collet depressed.

Pull the macroline hose out of the macroline fitting and release the collet.

Before installing the macroline hose into the macroline fitting ensure that the end has been trimmed correctly to ensure a tight fit in the fitting.

⚠ WARNING //////////////////////////////////////

IF YOU EVER REMOVE THE MACROLINE HOSE FROM THE FITTING, ALWAYS CHECK THE CONDITION OF YOUR MACROLINE HOISING AND IF IT IS WORN OR THE WRONG LENGTH REPLACE IT IMMEDIATELY.



QUICK GUIDE

CONTENTS

QUICK SET-UP

ORIENTATION

USING YOUR ETEK3

ADVANCED SET-UP

EMORTAL BOARD

MAINTENANCE

UPGRADING

FAULT FINDING

SERVICE CENTERS

PARTS LIST

SPARES & ACCESSORIES

INDEX

USING YOUR ETEK3



ATTACHING A LOADER

Using a 5/32" hex key, turn the top screw of the clamping feed neck counter clockwise (SEE FIGURE 7.1).

Release the clamping lever on the feed neck (SEE FIGURE 7.2) and test to see if your loader can easily be pushed into the top of the feed neck. If the loader cannot easily be pushed into the feed neck, loosen the top screw of the clamping feed neck a little more by turning it counter clockwise using a 5/32" hex key (SEE FIGURE 7.1).

When you have managed to push your loader into the clamping feed neck, close the clamp to secure it firmly in place (SEE FIGURE 7.3). If the loader is loose then you will need to release the clamp, tighten the top screw slightly by turning it clockwise with a 5/32" hex key to close the clamp. Repeat this process as necessary to secure your loader in place.

You have now attached a loader to your Etek3. Once you have filled your loader and air tank you will then be ready to begin using your Etek3.

⚠ WARNING //////////////////////////////////////
WARNING: DO NOT OVER TIGHTEN THE CLAMPING FEED NECK AS THIS MAY DAMAGE THE LOADER OR FEED NECK ITSELF.



FIG 7.1



FIG 7.2



FIG 7.3

SETTING THE TRIGGER

There are three adjustment points on the trigger – the Front Stop Trigger Screw, the Rear Stop Trigger Screw, and the Magnet Return Screw.

As standard each Etek3 comes with a factory set trigger travel of approximately 2mm in total length; one millimeter of travel before the firing point and one millimeter of travel after the firing point.

The Front Stop Trigger Screw is used to set the amount of trigger travel prior to the marker firing. Turn this screw clockwise to reduce the amount of travel. Do not turn the screw too far or the trigger will be pushed past the firing point and the marker will not work. Turn this screw counter clockwise to increase the amount of trigger travel (SEE FIGURE 8.1).

The Rear Stop Trigger Screw is used to set the amount of travel after the marker has fired. Turn this screw clockwise to reduce the amount of travel. Do not turn the screw too far or the trigger will be prevented from reaching its firing point and the marker will not work. Turn this screw counter clockwise to increase the amount of travel (SEE FIGURE 8.2).

The Magnet Return Screw is used to adjust the amount of return force with which the trigger is returned. Turn the screw clockwise to increase the amount of magnet return force. Do not turn the screw to far or it will negate the position of the Front Stop Trigger Screw. Turn the screw counter clockwise to reduce the amount of spring tension (SEE FIGURE 8.3)

EMORTAL BOARD USERS ONLY

When setting the trigger it is important to ensure that the electronic trigger detection is working correctly. When the trigger is fully depressed the Trigger Detection Indicator (TDI) should point upwards ☒. When the trigger is fully released the TDI should point downwards ☑. For more information, see 'Understanding the Trigger Detection Indicator' (TDI) on page 34 and the Filter menu on page 50.



FIG 8.1



FIG 8.2



FIG 8.3

QUICK GUIDE

CONTENTS

QUICK SET-UP

ORIENTATION

USING YOUR ETEK3

ADVANCED SET-UP

EMORTAL BOARD

MAINTENANCE

UPGRADING

FAULT FINDING

SERVICE CENTERS

PARTS LIST

SPARES & ACCESSORIES

INDEX

USING YOUR ETEK3

ADJUSTING THE VELOCITY

When using your Etek3, you may wish to change the velocity at which your Etek3 is firing. This is done by inserting a 1/8" hex key into the adjuster screw at the bottom of your Etek3 inline regulator and adjusting it accordingly (SEE FIGURE 9.1). By turning this adjuster screw clockwise you decrease the output pressure of the inline regulator and consequently the velocity, by turning the adjuster screw counter clockwise you increase the output pressure of the inline regulator and consequently the velocity¹. On the bottom of the inline regulator there are engraved arrows to illustrate which direction to turn the hex key to make the relevant adjustment.

ADJUSTING THE LPR PRESSURE

When using your Etek3, you may wish to change the output pressure of your LPR. This is easily done by inserting a 1/8" inch hex key into the adjuster screw at the front and adjusting it accordingly (SEE FIGURE 9.2). However we recommend that the LPR screw be left set 2 turns in (clockwise) from the screw being flush with the front of the LPR cap.

By turning the adjuster screw clockwise, you decrease the output pressure of your LPR and consequently reduce the pressure driving your rammer back and forth. By turning the adjuster screw counter clockwise, you increase the output pressure of your LPR and consequently increase the pressure driving your rammer back and forth.²

¹After each adjustment fire two clearing shots to gain an accurate velocity reading. Never exceed 300fps.

²Turning the adjuster screw in too far will prevent the Etek3 from firing.



FIG 9.1



FIG 9.2

THE TOURNAMENT LOCK

The Etek3 has an electronic tournament lock which, once enabled, prevents the user from making any changes to the setup parameters of the marker. This tournament lock complies with the rules of all major tournaments and must be enabled prior to entering the field of play in order to avoid penalties.

To enable the tournament lock -

1. Unscrew the three screws from the right hand side of the rubber grips (**SEE FIGURE 10.1**) using a 5/64" hex key.
2. Turn on the Etek3.
3. Locate and press the Lock button on the circuit board (**SEE FIGURE 10.2**). The Navigation Console will flash green to indicate that the tournament lock has been enabled.
4. Replace the three rubber grip screws using a 5/64" hex key.

To disable the tournament lock -

1. Unscrew the three screws from the right hand side of the rubber grips (**SEE FIGURE 10.1**) using a 5/64" hex key.
2. Turn on the Etek3.
3. Locate and press the Lock button on the circuit board (**SEE (A) IN FIGURE 10.2**). The Navigation Console will flash red to indicate that the tournament lock has been disabled.
4. Replace the three rubber grip screws using a 5/64" hex key.



FIG 10.1

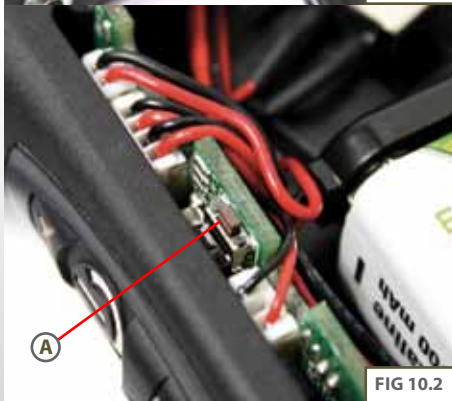

FIG 10.2

QUICK GUIDE

CONTENTS

QUICK SET-UP

ORIENTATION

USING YOUR ETEK3

ADVANCED SET-UP

EMORTAL BOARD

MAINTENANCE

UPGRADING

FAULT FINDING

SERVICE CENTERS

PARTS LIST

SPARES & ACCESSORIES

INDEX

USING YOUR ETEK3

UNDERSTANDING THE BBSS OPERATION

The Etek3 displays the status of the Break Beam Sensor System using the 'E' area of the Navigation Console as follows:

INDICATION	BREACH SENSOR STATUS
Flashing Yellow	BBSS enabled (On), no paintball detected - marker will not fire.
Flashing Light Blue	BBSS enabled (On), paintball detected - marker will fire.
Flashing Purple	BBSS disabled (Off) - marker will fire.
Fast Flashing Purple	Blockage detected, BBSS temporarily disabled (Off) - marker will fire.

Any changes to the Breach Sensor Status will be displayed immediately. This provides valuable feedback to the user.

An example of this is when you are shooting a string of shots with the BBSS enabled, the "E" on the Navigation Console will alternate in colour from Yellow (no paintball detected) to Light Blue (paintball detected). In this instance too much yellow would indicate that your chosen loader cannot keep up with how fast you are shooting and is consequently slowing down your rate of fire.

The BBSS is able to switch itself off in the event that a blockage or contamination prevents it from functioning correctly. This is represented by a fast flashing purple light in the "E" area of the Navigation Console. The Etek's ROF will be capped at 7.5bps. In this instance, the BBSS will switch itself back on once the blockage is cleared and the correct operation of the BBSS can then be resumed.

THE BATTERY LEVEL INDICATOR

The Etek3 displays the status of the battery using the 'G' area of the Navigation Console. When the battery is fresh 'G' LED flash green.

As the battery is drained the 'G' LED will change colour from green to yellow.

When the battery reaches a level where it will no longer function reliably, the 'G' LED will start to flash red. At this point the battery must be changed for a new one. For instructions on installing a new battery see page 10.

THE SET UP MODE

The *SET UP MODE* can only be entered if tournament lock is off. See page 25 for details on the tournament lock.

To activate the *SET UP MODE*, firstly ensure that the Etek3 is switched off. Pull and hold the trigger, and whilst the trigger is still pulled push and hold the **U** button until the 'E' and the 'O' on the Navigation Console alternately flash white to indicate entry to *SET UP MODE*. When you have entered the *SET UP MODE*, the 'G' on the Navigation Console will turn red to indicate the first parameter of the *SET UP MODE*. You can now release the trigger.

Press the **U** button to scroll through each of the parameters on the *SET UP MODE*:

COLOUR	PARAMETER	RANGE
Red	Firing Mode	1 to 3
Green	Maximum ROF with BBSS on (for capped modes only).	4.0 bps to 15.4 bps
Blue	Maximum ROF with BBSS off.	4.0 bps to 15.4 bps
White	Ramp Kick-in Rate (ramp only)	5.0 pps to 10.0 pps
Dark Red	Ramp Restart Time (ramp only)	0.0 to 1.0 s
Purple	Dwell	1.0 ms to 15.0 ms
Light Blue	Debounce	1 to 10
Yellow	Ball Detection Time	1 ms to 10 ms

To see the value that any setup parameter is set to, pull and release the trigger, the value will be indicated by flashing the tens on the 'E' LED, the units on the 'G' LED and tenths on the 'O' LED. E.g. 14.5 would be indicated as follows-

- 1 FLASH OF THE 'E' LED
- 4 FLASHES OF THE 'G' LED
- 5 FLASHES OF THE 'O' LED

A zero is indicated by no flashes. E.g. 3.0 would be indicated as follows:

- 0 FLASHES OF THE 'E' LED
- 3 FLASHES OF THE 'G' LED
- 0 FLASHES OF THE 'O' LED

MODIFYING A PARAMETER

You can modify a parameter by using the following guidelines.

1. Ensure that you are in *SET UP MODE*.
2. Choose the parameter that you wish to modify by pressing **U** until G turns to the parameter colour.
3. Pull and hold the trigger for 1 second. The 'E' LED will light up.
4. Set the tens digit by pressing the trigger once for each ten, the 'E' LED will flash with each trigger pull. DO NOT pull the trigger if the required digit is zero.
5. Push the **U** button. The 'G' LED on the Navigation Console is illuminated.
6. Set the units digit by pressing the trigger once for each unit, the 'G' LED will flash with each trigger pull. DO NOT pull the trigger if the required digit is zero.
7. Push the **U** button. The 'O' on the Navigation Console is illuminated.
8. Set the units digit by pressing the trigger once for each unit, the 'O' LED will flash with each trigger pull. DO NOT pull the trigger if the required digit is zero.
9. Push the **U** button. The "E", "G" and "O" will flash three times; if the colour is green then the value has been accepted and saved, if the value is red then the value has been rejected and restored to its value before modifying.

For example to set a parameter to 14.5 -

- PULL THE TRIGGER 1 TIME WHILE THE 'E' LED IS LIT THEN PRESS **U**
- PULL THE TRIGGER 4 TIMES WHILE THE 'G' LED IS LIT THEN PRESS **U**
- PULL THE TRIGGER 5 TIMES WHILE THE 'O' LED IS LIT THEN PRESS **U**

To leave a parameter unchanged having already started to modify it, simply set an illegal value (any single digit greater than 9) and the value will consequently be rejected.

QUICK GUIDE

CONTENTS
QUICK SET-UP
ORIENTATION
USING YOUR ETEK3
ADVANCED SET-UP
EMORTAL BOARD
MAINTENANCE
UPGRADING
FAULT FINDING
SERVICE CENTERS
PARTS LIST
SPARES & ACCESSORIES
INDEX

ADVANCED SET-UP

SET UP PARAMETERS

The first five set up parameters will need to be set to comply with the rules of the field or site at which this Etek3 is used. It is the user's responsibility to ensure that these parameters are correctly set.

THE FIRING MODE PARAMETER

This parameter is used to control the firing mode of the Etek3. The *FIRING MODE* parameter is indicated by a red light on the Navigation Console when you are in the *SET UP* mode. There are three selectable *FIRING MODES* as outlined below:

1.0 : UNCAPPED SEMI

In this mode the Etek3 will fire one shot for every pull of the trigger. This mode is uncapped with the BBSS enabled. If the BBSS is off then the rate of fire is limited by the *MAXIMUM ROF WITH BBSS OFF* parameter.

2.0 : CAPPED SEMI

This mode is the same as the *UNCAPPED SEMI* mode, except that the rate of fire is capped to the *MAXIMUM ROF WITH BBSS ON* parameter.

3.0 : CAPPED RAMP

This mode allows the rate of fire to ramp to a maximum set by the *MAXIMUM ROF WITH BBSS ON* parameter, once the trigger is being pulled at the required pulls per second rate set by the *RAMP KICK-IN RATE* parameter. The number of trigger pulls has to remain equal or above the *RAMP KICK-IN RATE* parameter to continue ramping. After the last trigger pull, the ramp can be restarted with a single trigger pull within the time set in the *RAMP RESTART TIME* parameter.

Certain modes may only be available in certain countries and on certain models of the Etek3.



THE MAXIMUM ROF WITH BBSS ON (CAPPED MODES)

In capped firing modes this parameter is used to control how fast the Etek3 can cycle.

The *MAXIMUM ROF WITH BBSS ON* parameter is indicated by a green light on the Navigation Console when you are in the *SET UP* mode.

This is fully adjustable between 4.0 balls per second and 15.4 balls per second in 0.1 bps increments.



THE MAXIMUM ROF WITH BBSS OFF

This parameter is used to control how fast the Etek3 cycles when the Break Beam Sensor System has been disabled.

The *MAXIMUM ROF WITH BBSS OFF* parameter is indicated by a blue light on the Navigation Console when you are in the *SET UP* mode.

This parameter is fully adjustable between 4.0 balls per second and 15.4 balls per second in 0.1 bps increments.

This parameter should be set to match the slowest speed of the loading system in use.



RAMP KICK-IN RATE (RAMP ONLY)



The *RAMP KICK-IN RATE* parameter sets the rate at which the trigger has to be pulled in order to start and maintain ramping.

The *RAMP KICK-IN RATE* parameter is indicated by a white light on the Navigation Console when you are in the *SET UP* mode.

This parameter can be set between 5.0 and 10.0 pulls per second in 0.1 pps increments.

RAMP RESTART TIME (RAMP ONLY)



The *RAMP RESTART TIME* parameter sets the time during which ramping can be restarted with a single trigger pull, after the previous ramping string has stopped.

The parameter is specified in seconds and if set to 0.0 then ramping can only be restarted with four shots at the *RAMP KICK-IN RATE*. The *RAMP RESTART TIME* parameter is indicated by a dark red light on the Navigation Console when you are in the *SET UP* mode.

This parameter is fully adjustable between 0.0 and 1.0 seconds.

QUICK GUIDE

CONTENTS

QUICK SET-UP

ORIENTATION

USING YOUR ETEK3

ADVANCED SET-UP

EMORTAL BOARD

MAINTENANCE

UPGRADING

FAULT FINDING

SERVICE CENTERS

PARTS LIST

SPARES & ACCESSORIES

INDEX

ADVANCED SET-UP

SET UP PARAMETERS TABLE

The following table lists the setup parameters required for compliance with the 2009 rules for the major paintball leagues. For your convenience there is space to add settings for future rule changes.

	USPL/NPPL	PSP (PRO)	PSP (DIVISIONAL)	MILLENNIUM
Fire Mode	1.0	3.0	3.0	3.0
Maximum ROF (BBSS on)	N/A	12.0	10.0	10.0
Maximum ROF (BBSS off)	N/A	10.0	10.0	10.0
Ramp Kick-in Rate	N/A	5.0	5.0	5.0
Ramp Restart Rate	N/A	1.0	1.0	0.0

Fire Mode				
Maximum ROF (BBSS on)				
Maximum ROF (BBSS off)				
Ramp Kick-in Rate				
Ramp Restart Rate				

THESE PARAMETERS ARE CORRECT AT TIME OF PRINTING AND ARE ONLY TO BE TREATED AS A GUIDE. IT IS THE USER OF THIS ETEK3'S RESPONSIBILITY TO ENSURE THAT THESE PARAMETERS STILL COMPLY WITH THE RULES OF THE FIELD, SITE AND/OR TOURNAMENT THAT THE ETEK3 IS BEING USED AT.

The remaining set up parameters are used to configure the performance of the Etek3.

DWELL

The *DWELL* parameter controls the amount of time that the solenoid is energised and therefore the amount of gas that is released with each shot.

The *DWELL* parameter is indicated by a purple light on the Navigation Console when you are in the *SET UP* mode.

This parameter is fully adjustable between 1.0ms and 15.0ms in 0.1ms increments.



DEBOUNCE

The *DEBOUNCE* parameter is used to set the level of Debounce (anti trigger bounce) on your Etek3.

The *DEBOUNCE* parameter is indicated by a 'light blue' light on the Navigation Console when you are in the *SET UP* mode.

This parameter is fully adjustable between Debounce 1 and Debounce 10 with a higher value reducing the amount of trigger bounce.



THE BALL DETECTION TIME

The *BALL DETECTION TIME* parameter defines how long a paintball has to sit in the breach of the Etek3 before it is considered ready to fire.

The *BALL DETECTION TIME* parameter is indicated by a yellow light on the Navigation Console when you are in the *SET UP* mode.

This parameter is fully adjustable between 1 ms and 10 ms in 1 ms increments.

THE RESET PARAMETER

Whilst in *SET UP MODE*, it is possible to reset all of the control parameters to the factory default settings in the following way:

1. Push and hold the Lock button for two seconds.
2. The "E", "G" and "O" on the Navigation Console will repeatedly flash blue to indicate that the factory default settings have been restored.



QUICK GUIDE

CONTENTS
QUICK SET-UP
ORIENTATION
USING YOUR ETEK3
ADVANCED SET-UP
EMORTAL BOARD
MAINTENANCE
UPGRADING
FAULT FINDING
SERVICE CENTERS
PARTS LIST
SPARES & ACCESSORIES
INDEX

ADVANCED SET-UP

THE EMORTAL BOARD NAVIGATION CONSOLE

At the rear of the Etek3 grip frame you will find the Navigation Console (FIGURE 11.1).

The Navigation Console is used for;









- > TURNING THE ETEK3 ON AND OFF USING THE  BUTTON
- > SCROLLING THROUGH MENUS WITH THE  AND  BUTTONS
- > SELECTING PARAMETERS TO EDIT USING THE  BUTTON
- > EDITING PARAMETERS USING THE  AND  BUTTONS
- > TURNING THE ETEK3 BBSS ON AND OFF USING THE  BUTTON
- > RESETING RECORDED VALUES USING THE  BUTTON
- > CONTROLLING THE GAME TIMER WITH THE  BUTTON



FIG 11.1

USER INTERFACE

The Etek3 has a simple user interface through which all aspects of its electronic control system can be monitored and adjusted by means of the three buttons and graphical LCD which comprise the Navigation Console.

SWITCHING ON

The Etek3 is switched on by pushing and holding the  button. The LCD will display startup information including model number and software version before displaying the Run Screen if the  button continues to be held down during startup.

RUN SCREEN LAYOUT

The root of the user interface is the Run Screen. This screen is the one most often displayed and provides the user with essential feedback on the state of the Etek3. A typical Run Screen is shown on the right.

On the left of the screen is a display option that is user selectable from the Main Menu (see page 42).

This option can be:-

- > A GAME TIMER
- > A SHOT COUNTER
- > AN ACTUAL RATE OF FIRE INDICATOR
- > A PEAK RATE OF FIRE INDICATOR

Briefly pressing the  button will replace the display option with the name of the currently selected Preset (see page 44), or CUSTOM if a parameter of the selected preset mode has been edited.

On the right of the screen are up to five icons, each of which provides graphical indication on different parts of the Etek3 control electronics.

BREAK BEAM SENSOR SYSTEM INDICATOR

TRIGGER DETECTION INDICATOR

USER SELECTABLE DISPLAY OPTION

LOCK INDICATOR

BATTERY LEVEL INDICATOR

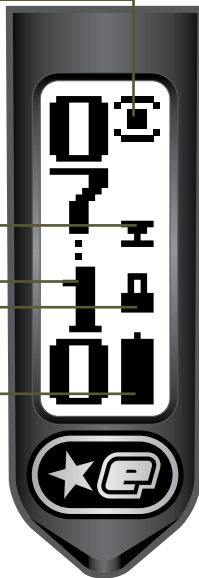

QUICK GUIDE

CONTENTS
QUICK SET-UP
ORIENTATION
USING YOUR ETEK3
ADVANCED SET-UP
EMORTAL BOARD
MAINTENANCE
UPGRADING
FAULT FINDING
SERVICE CENTERS
PARTS LIST
SPARES & ACCESSORIES
INDEX

EMORTAL BOARD

UNDERSTANDING THE BBSS INDICATOR (BBSS)

The BBSS is able to switch itself off in the event that a blockage or contamination prevents it from functioning correctly. In this instance, the BBSS will switch itself back on once the blockage is cleared and the correct operation can be resumed.

The BBSS Indicator on the main screen is used to indicate the eight possible states of the BBSS as follows:



BBSS ENABLED AND BALL DETECTED

The Etek3 can be fired at the maximum rate of fire determined by the chosen firing mode.



BBSS ENABLED NO BALL DETECTED

The Etek3 cannot be fired.



BBSS DISABLED

The Etek3 can be fired at a maximum rate of fire as set by the **OFF ROF** parameter (see page 47)



BBSS FAULT DETECTED

The system is disabled. The Etek3 can only be fired at a maximum rate of fire of 7.5bps, regardless of the chosen firing mode.



BBSS SENSOR FAULT HAS BEEN CLEARED

The sensor has been re-enabled. A ball is detected and the Etek3 can be fired at the maximum rate of fire determined by the chosen firing mode.



BBSS FAULT HAS BEEN CLEARED

The sensor is enabled. No ball is detected so the Etek3 cannot be fired. To reset the BBSS icon, use the button to switch off the BBSS and then back on again.



BBSS ENABLED IN TRAINING MODE

The BBSS has been over-ridden as the user has selected training mode. As the user has chosen to leave the BBSS on, the achievable rate of fire is limited by the firing mode.



BBSS DISABLED IN TRAINING MODE

The BBSS has been over-ridden as the user has selected training mode. As the user has chosen to turn the BBSS off, the achievable rate of fire is limited by the **OFF ROF** parameter (see page 47).

UNDERSTANDING THE TRIGGER DETECTION INDICATOR (TDI)

In order for the trigger to be successfully operated it must first be released and then pulled. The Trigger Detection Indicator (TDI) is used to indicate each of the possible trigger states.



MICRO-SWITCH NOT ACTUATED

The micro-switch is not currently actuated, i.e. the trigger is released.





MICRO-SWITCH ACTUATED

The micro-switch is currently actuated, i.e. the trigger is pulled.

UNDERSTANDING THE LOCK INDICATOR

The Etek3 has a tournament lock which prevents the user from making changes to any parameter that affects the way in which the Etek3 shoots, without the need for tools. This feature is necessary in order to make the Etek3 legal for tournament play.

When the lock is enabled the lock indicator will show a closed padlock .



When the lock is disabled the lock indicator will show an open padlock .

UNDERSTANDING THE BATTERY LEVEL INDICATOR

The battery level indicator is used to show the state of the battery within the Etek3. When the battery is fresh the indicator will show a 'full' battery  and as the battery is drained, so the indicator will show the battery emptying. When the battery reaches a point at which the Etek3 will no longer function reliably, the indicator will start to flash. At this point the battery must be changed immediately.

THE GAME TIMER

When the Game Timer is shown on the Run Screen then it can be started by pressing the  button and the timer will start to count down. The Game Timer can also be configured to start on a trigger press with the *START* parameter (see page 42).

When the Game Timer reaches 00:00, GAME OVER will be displayed. To stop the Game Timer at any time press and hold the  button for 0.5 seconds. To reset the Game Timer to its preset start time, push and hold the  button for 1 second. The Game Timer will also be reset whenever the Etek3 is switched off.

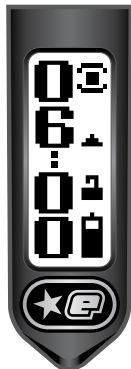

THE SHOT COUNTER

The Shot Counter increments every time that the Etek3 is fired, regardless of whether the Shot Counter is displayed or not. When the Shot Counter is displayed on the Run Screen it can be reset to 0 by pressing and holding the  button for 0.5 seconds.

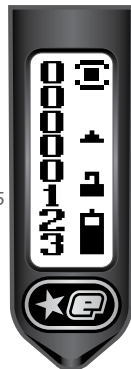

QUICK GUIDE

CONTENTS
QUICK SET-UP
ORIENTATION
USING YOUR ETEK3
ADVANCED SET-UP
EMORTAL BOARD
MAINTENANCE
UPGRADING
FAULT FINDING
SERVICE CENTERS
PARTS LIST
SPARES & ACCESSORIES
INDEX

EMORTAL BOARD

THE ACTUAL RATE OF FIRE

When the *ACTUAL ROF* is selected for display the Run Screen will look something like the screen to the right. The value displayed in the top left of the screen represents the number of full cycles completed in the last second - the actual rate of fire over the second. The number below it is the maximum actual rate of fire that has been recorded. To reset this maximum, press and hold the button for 0.5 seconds.



THE PEAK RATE OF FIRE

When the *PEAK ROF* is selected for display the Run Screen will look something like the screen to the left, which differs from the display of the *ACTUAL ROF* by the inclusion of the indicator 'PK'. The value displayed in the top left of the screen represents the rate of fire measured between the last two shots. The number below it is the maximum peak rate of fire that has been recorded. To reset this maximum, press and hold the button for 0.5 seconds.



The *PEAK ROF* is typically higher than the *ACTUAL ROF* as it is much easier to fire two shots in quick succession than it is to maintain a string over a longer period of time.

THE MENU SYSTEM

Behind the Run Screen is a structured menu system comprised of multiple levels of menus. Each menu contains a number of menu items and each menu item can either be an editable parameter or a branch to another menu. Branches always have an animated graphic whereas parameters indicate their current value.

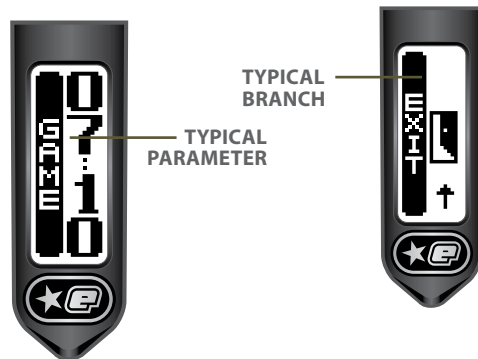

The menu structure is shown in the following pages.

The menus are 'smart menus' in that they will expand and contract depending upon the state of certain parameters. For example, the *MAX ROF* parameter is only visible when the *ROF CAP* parameter is set to 'on'. Smart menu items are indicated with a * in the table opposite.

MAIN MENU

MAIN MENU

—	OFF?		Turn off the Etek3
—	DISPLAY	Timer Shots ACT ROF Peak ROF Cancel	Display the game timer on the Run Screen Display the shot counter on the Run Screen Display the actual rate of fire on the Run Screen Display the peak rate of fire on the Run Screen Cancel the display selection
—	TIMER		
—	GAME	00:00 - 60:00	Countdown game timer start time
—	ALARM	00:00 - 10:00	Alarm activation time
—	START	Button Trigger Cancel	▼ button starts the game timer Trigger pull starts the game timer Cancel game timer start event selection
—	BACK		Go back one menu level
—	EXIT		Return to the Run Screen

Parameters followed by a * are part of the smart menu system and will be displayed depending on your chosen settings. (e.g. The MAX ROF parameter will only become available if the ROF CAP parameter is set to on).

QUICK GUIDE

CONTENTS

QUICK SET-UP

ORIENTATION

USING YOUR ETEK3

ADVANCED SET-UP

EMORTAL BOARD

MAINTENANCE

UPGRADING

FAULT FINDING

SERVICE CENTERS

PARTS LIST

SPARES & ACCESSORIES

INDEX

EMORTAL BOARD

SET-UP MENU

SET-UP MENU

LOCK	Off	Turn the tournament lock off	
	On	Turn the tournament lock on	
	Cancel	Make no changes to the tournament lock	
PRESET	LOAD	User 1	Load the User 1 settings
		User 2	Load the User 2 settings
		Factory	Load the default factory settings (semi-automatic)
		NPPL	Load NPPL 2008 compliant settings
		PSP 10	Load the PSP 10 balls per second (BPS) compliant settings
		PSP 12	Load the PSP 12 balls per second (BPS) compliant settings
		MS 10	Load Millennium Series 2010 compliant settings
	Cancel	Cancel the load operation	
	SAVE	User 1	Save the current settings as the User 1 settings
		User 2	Save the current settings as the User 2 settings
Cancel		Cancel the save operation	
BACK		Go back one menu level	
MODE	Semi	Select semi-automatic mode of fire	
	Ramp	Select ramping mode of fire	
	Cancel	Cancel the mode selection	
ROF CAP	Off	Turn off the rate of fire cap	
	On	Turn on the rate of fire cap	
	Cancel	Cancel the ROF cap selection	
MAX ROF*	4.0 - 22.0	Rate of fire cap in balls per second when BBSS is enabled	
OFF ROF	4.0 - 15.0	Rate of fire cap in balls per second when BBSS is disabled	

SET-UP MENU

RAMP SET*

TYPE	Step Linear Cancel	Select step type ramping Select linear type ramping Cancel the ramp type selection
RATE	0 - 100	Percentage linear ramp rate
PULL NO	4 - 9	Number of shots before ramping can start
KICK IN	5.0 - 15.0	Rate at which trigger has to be pulled in pulls per second before ramping can start
SUSTAIN	5.0 - 15.0	Rate at which trigger has to be pulled in pulls per second in order to maintain ramping
RESTART	0.0 - 1.0	Time in seconds after last trigger pull during which ramp can be restarted
BACK		Go back one menu level

TIMING

DWELL	0.0 - 15.0	Solenoid energise time in milliseconds for each shot
FSD COMP	0.0 - 5.0	First shot drop-off compensation time in milliseconds
FSD DLY	30 - 240	Delay in seconds before 'First Shot Drop Off Compensation' is applied
LIGHT	0.0 - 20.0	Backlight off delay in seconds
SLEEP	5 - 60	Auto power off time in minutes
BACK		Go back one menu level

FILTER

DBOUNCE	Level 9 . . Level 1 Cancel	Use trigger debounce level 9 (less bounce) Use trigger debounce level 1 (more bounce) Cancel debounce selection
EMPTY	1.0 - 10.0	Time in milliseconds that the breech must remain empty before the BBSS can look for a paintball.

QUICK GUIDE

- CONTENTS
- QUICK SET-UP
- ORIENTATION
- USING YOUR ETEK3
- ADVANCED SET-UP
- EMORTAL BOARD**
- MAINTENANCE
- UPGRADING
- FAULT FINDING
- SERVICE CENTERS
- PARTS LIST
- SPARES & ACCESSORIES
- INDEX

EMORTAL BOARD



SET-UP MENU



FULL	1.0 - 20.0	Time in milliseconds that a paintball must be in the breech for the Etek3 to be ready to fire
PULL TM	3.0 - 25.0	Time in milliseconds that the trigger must be pulled in order for a shot to be fired
REL TM	3.0 - 25.0	Time in milliseconds the trigger must be released prior to being pulled
BACK		Go back one menu level
EXIT		Return to the Run Screen



ACCESSING THE MENU SYSTEM

To access the Main Menu from the Run Screen push and hold the  button for 2 seconds.

To access the Set-up Menu from either the Run Screen or the Main Menu push the internal Setup button and the first item on the Set-up Menu will be displayed.¹

MOVING AROUND THE MENUS

Press and release the  button to display the next item on the menu. When the last menu item is displayed, pressing the  button will display the first item.

Press and release the  button to display the previous item on the menu. When the first menu item is displayed, pressing the  button will display the last item.

When the displayed item is a branch, as indicated by an animation on the right of the screen, press the  button to move to another menu.





¹If the tournament lock is set to 'off' then the Main Menu and Set-up Menu are joined together which means that they can be accessed in either of the two ways above.







ALTERING PARAMETERS

When the displayed item is a parameter, as indicated by a parameter value on the right of the screen, pressing the  button will activate the EDIT mode which allows the parameter value to be altered. When EDIT mode is active, edit indicators appear on the left of the screen as shown in the screen below.

EDIT INDICATORS

There are two types of parameter, numeric parameters and choice parameters. A numeric parameter has a value which is a number whereas a choice parameter is one that has a small number of distinct choices. Altering parameter values is essentially the same for both types of parameter.

To alter a numeric parameter, first activate the EDIT mode. Press the  button to increase the parameter value one step at a time. Press and hold the  button to increase the parameter value rapidly. When the value reaches it's maximum it will revert to it's minimum value. Press the  button to decrease the parameter value one step at a time. Press and hold the  button to decrease the parameter value rapidly. When the value reaches it's minimum it will revert to it's maximum value. When the required parameter value is displayed press the  button to accept the value and end the EDIT mode.

To alter a choice parameter, first activate the EDIT mode. Press the  button to display the next choice in the list. When the last choice is displayed, pressing  will display the first choice in the list. Press the  button to display the previous choice in the list. When the first choice is displayed, pressing the  button will display the last choice in the list. When the required choice is displayed press the  button to accept the choice and end the EDIT mode. If the displayed choice is Cancel then pressing the  button will end the EDIT mode and restore the parameter to the value that is was prior to editing.



QUICK GUIDE

CONTENTS
QUICK SET-UP
ORIENTATION
USING YOUR ETEK3
ADVANCED SET-UP
EMORTAL BOARD
MAINTENANCE
UPGRADING
FAULT FINDING
SERVICE CENTERS
PARTS LIST
SPARES & ACCESSORIES
INDEX

EMORTAL BOARD

THE MAIN MENU

The Main Menu comprises parameters that do not affect the way in which the Etek3 shoots and which therefore do not have to be tournament locked.¹

DISPLAY

THE DISPLAY PARAMETER

This parameter is used to select the information that is displayed on the left of the Run Screen. This parameter has the following choices:-

- > **TIMER:** The Game Timer is displayed on the Run Screen
- > **SHOTS:** The Shot Counter is displayed on the Run Screen
- > **ACT ROF:** The Actual Rate of Fire is displayed on the Run Screen
- > **PEAK ROF:** The Peak Rate of Fire is displayed on the Run Screen
- > **CANCEL:** Editing is cancelled and the parameter remains unchanged.

This parameter differs from most others in that once a choice has been made then the EDIT mode is ended and the display returns to the Run Screen.



TIMER

THE GAME TIMER MENU

This menu is comprised of parameters that control the operation of the Game Timer:

GAME

THE GAME TIME PARAMETER

This parameter is used to set the game time; the time from which the Game Timer counts down to zero. This parameter can be set between 00:00 and 60:00 minutes in 10 second increments and the factory default is 07:10 (7 minutes 10 seconds).



START

THE TIMER START PARAMETER

This parameter is used to select the event which will cause the Game Timer to begin counting down. This parameter has the following choices:

- > **BUTTON:** Pressing the button will start the game timer.
- > **TRIGGER:** Pulling the trigger will start the game timer.
- > **CANCEL:** Cancel editing and leave the parameter unchanged.



¹If the lock option is disabled further options will be displayed in the main menu.

THE SETUP MENU

This menu is the starting point for access to all of the parameters that control the way that the Etek3 operates. To access this menu, first turn on the Etek3 and then remove the 3 screws holding the right hand cheek of the rubber grips (SEE FIGURE 12.1). Peeling back the cheek will reveal a red Setup button (A) on the circuit board (SEE FIGURE 12.2), push and hold this button for 2 seconds.

If the tournament lock (LOCK) is off then this menu is joined to the end of the Main Menu and can therefore be accessed without tools.

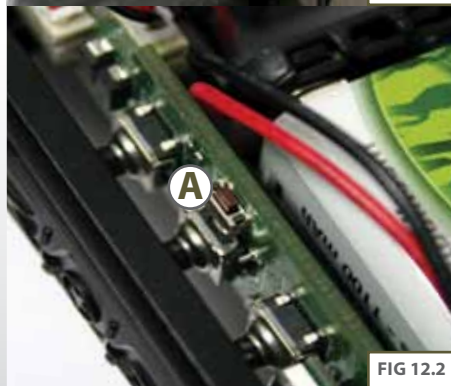

QUICK GUIDE

CONTENTS
QUICK SET-UP
ORIENTATION
USING YOUR ETEK3
ADVANCED SET-UP
EMORTAL BOARD
MAINTENANCE
UPGRADING
FAULT FINDING
SERVICE CENTERS
PARTS LIST
SPARES & ACCESSORIES
INDEX

EMORTAL BOARD

LOCK

THE TOURNAMENT LOCK PARAMETER

The Etek3 has a tournament lock which prevents the user from making changes to any parameter that affects the way in which the Etek3 shoots without the use of tools.

This parameter is used to set the state of the tournament lock and has the following choices:-

> **ON:** Turn on the tournament lock. The Set-Up Menu is only accessible by removing the right hand cheek of the rubber grips and then pressing and holding the red **SETUP** button on the circuit board.

> **OFF:** Turn off the tournament lock. The Set-Up Menu is added to the Main Menu, making it easily accessible by pressing and holding the button.

> **CANCEL:** Cancel selection and leave the parameter unchanged.



PRESET

THE PRESET MENU

In order to simplify the set up of the Etek3 a number of Preset configurations are available for selection. Choosing one of these presets will cause all of the necessary parameters to be set in such a way as to make the Etek3 comply with the rules governing a particular paintball league. It is also possible for the user to save up to two Preset configurations of their own.^{1,2,3}

LOAD

THE LOAD PRESET PARAMETER

This parameter is used to load the required preset configuration and has the following choices:

> **USER 1:** Load a set of custom firing mode parameters that have been previously saved by the user.

> **USER 2:** Load a set of custom firing mode parameters that have been previously saved by the user.

> **FACTORY:** Reset every parameter to the factory set default. The Etek3 leaves the factory set in this way.

> **NPPL:** Load a set of parameters that configures the Etek3 to comply with the 2008 NPPL rules governing firing modes.¹

> **PSP 10:** Load a set of parameters that configures the Etek3 to comply with the PSP rules governing firing modes in lower divisions (10bps).¹

> **PSP 12:** Load a set of parameters that configures the Etek3 to comply with the PSP rules governing firing modes in higher divisions (12bps).¹

> **MS10:** Load a set of parameters that configures the Etek3 to comply with the 2010 Millennium Series rules governing firing modes.¹

> **CANCEL:** Editing is cancelled and the parameter remains unchanged.



SAVE

THE SAVE PRESET PARAMETER

This parameter is used to save the current set of parameters as a user defined custom Preset configuration. This parameter has the following choices:-

- > **USER 1:** Save the current parameters as the preset 'USER 1'.
- > **USER 2:** Save the current parameters as the preset 'USER 2'.
- > **CANCEL:** Editing is cancelled and the parameter remains unchanged.

With the exception of **FACTORY** each of the Presets changes only those parameters that control the firing mode of the Etek3, leaving **FILTER** and **TIMING** unchanged.



MODE

THE FIRING MODE PARAMETER

This parameter is used to select the firing mode of the Etek3 and has the following choices:

- > **SEMI:** This is the default and in this firing mode the Etek3 will fire one shot for every trigger pull.
- > **RAMP:** In this firing mode, the rate of fire is increased above the rate at which the trigger is pulled once certain criteria have been met. These criteria are set by the parameters on the Ramp Set Menu.³
- > **CANCEL:** Editing is cancelled and the parameter is unchanged.



¹All presets are correct at time of printing. Please check with the event organiser to make sure the above presets are still considered legal.

²The current preset configuration can be viewed from the run screen by pressing the  button.

³Certain modes may only be available in certain countries and on certain models of the Etek3.

QUICK GUIDE

CONTENTS
QUICK SET-UP
ORIENTATION
USING YOUR ETEK3
ADVANCED SET-UP
EMORTAL BOARD
MAINTENANCE
UPGRADING
FAULT FINDING
SERVICE CENTERS
PARTS LIST
SPARES & ACCESSORIES
INDEX

EMORTAL BOARD

ROF CAP

THE RATE OF FIRE CAP PARAMETER

The *ROF CAP* parameter is used to specify whether or not the Etek3 should have a limited, or capped rate of fire. When the *ROF CAP* is enabled, the maximum achievable rate of fire is set by the *MAX ROF* parameter. Choices for the *ROF CAP* parameter are:-

- > **OFF:** Rate of Fire only limited by the loader.
- > **ON:** Rate of Fire limited to the *MAX ROF* parameter value.
- > **CANCEL:** Cancel editing and leave the parameter unchanged.

If the *ROF CAP* is switched on, then the *MAX ROF* parameter will feature as an item in the Set-Up Menu. If the *ROF CAP* is switched off, the *MAX ROF* parameter is redundant and omitted from the Set-Up Menu.



MAX ROF

THE MAXIMUM RATE OF FIRE PARAMETER

The *MAX ROF* parameter is used to set the maximum achievable rate of fire from the Etek3. The value of this parameter can be adjusted between 4.0 and 22.0 balls per second in 0.1bps increments.

The *MAX ROF* parameter will only be displayed if you have set the *ROF CAP* parameter to 'ON'.



OFF ROF

THE RATE OF FIRE WHEN BBSS OFF PARAMETER

The *OFF ROF* parameter is used to control how fast the Etek3 cycles when the Break Beam Sensor System is disabled. This parameter can be set between 4.0 and 15.0 balls per second and should always be set to the slowest speed of the loading system in use.



RMP SET

THE RAMP SETTINGS MENU

This menu is only available when ramping has been selected with the *MODE* parameter and comprises a list of parameters that control the way in which the Etek3 ramps, as shown below:

TYPE

THE RAMP TYPE PARAMETER

This parameter is used to select the ramping style and has the following choices:-

> **STEP:** Step ramping will cause the Etek3 to shoot in semi-automatic until a number of trigger pulls, set by *PULL NO*, have been made at a minimum pull rate, set by *KICK IN*. At this point the rate of fire will step up to the maximum rate of fire as set by *MAX ROF* (or the maximum loader speed if the *ROF CAP* parameter is set to off). Ramping is maintained as long as the user continues to pull the trigger at a required rate set by *SUSTAIN*.

> **LINEAR:** Linear ramping will cause the Etek3 to shoot in semi-automatic until a number of trigger pulls, set by *PULL NO*, have been made at a minimum pull rate, set by *KICK IN*. At this point the rate of fire will equal the rate of trigger pulls increased by the percentage specified by *RATE* up to a maximum rate of fire as set by *MAX ROF*, if the *ROF CAP* is on. Ramping is maintained as long as the user continues to pull the trigger at a required rate set by *SUSTAIN*.

> **CANCEL:** Editing is cancelled and no changes are made to the parameter.



QUICK GUIDE

CONTENTS
QUICK SET-UP
ORIENTATION
USING YOUR ETEK3
ADVANCED SET-UP
EMORTAL BOARD
MAINTENANCE
UPGRADING
FAULT FINDING
SERVICE CENTERS
PARTS LIST
SPARES & ACCESSORIES
INDEX

EMORTAL BOARD

RATE

THE LINEAR RAMP RATE PARAMETER

The parameter is only available when *LINEAR* Ramping is selected and is used to set the percentage increase in rate of fire over rate of trigger pulls.

For example, if the user is pulling the trigger at a rate of 10 pulls per second and the *RATE* parameter is set to 50% then the rate of fire is 10 plus 50% extra which is 15 balls per second.

This parameter can be set between 0 and 100% in 10% increments.

PULL NO

THE RAMP START PARAMETER

The parameter sets the number of trigger pulls that are required at the *KICK IN* rate before ramping will start. The parameter can be set between 4 and 9 pulls in increments of 1.

KICK IN

THE RAMP KICK-IN PARAMETER

This parameter sets the minimum rate at which the user has to pull the trigger in order to start ramping. This parameter can be set between 5.0 and 15.0 pulls per second in 0.1 pulls per second increments.



SUSTAIN

THE SUSTAIN RATE PARAMETER

Once the Etek3 is ramping the user has to continue to pull the trigger at a minimum rate in order to maintain the ramping. This parameter sets this rate and can be between 5.0 and 15.0 pulls per second in 0.1 pulls per second increments.



RESTART

THE RAMP RESTART PARAMETER

The *RESTART* parameter defines the amount of time after the last trigger pull during which the ramp can be restarted with a single trigger pull. If a trigger pull occurs after the *RESTART* time has expired, then the other ramp start conditions have to be met before ramping will restart. This parameter can be set between 0.0 and 1.0 seconds in 0.1 second increments.



TIMING

THE TIMING MENU

The parameters on the Timing Menu all relate to the timing of specific events.

DWELL

THE DWELL PARAMETER

The *DWELL* parameter sets the amount of time that the solenoid is energized and therefore the amount of air that is released with each shot of the Etek3. Setting this parameter too low will result in low velocity shots and/or excessive shot to shot velocity fluctuations. Setting the parameter too high will simply waste gas and make the Etek3 louder.

The *DWELL* can be set between 0.0 and 25.0 milliseconds. The factory default setting can normally be reduced after a few thousand shots as the Etek3 'beds-in'.



FSD COMP

THE FIRST SHOT DROP-OFF COMPENSATION PARAMETER

First shot drop off is a reduction in velocity of the first shot fired after an extended period of not firing and is caused by the stiction between dynamic o-rings and the surfaces that they are in contact with. In order to compensate for FSD this parameter can be set to add extra time to the *DWELL* parameter for the first shot. This parameter can be set between 0.0 and 5.0 milliseconds.



FSD DLY

THE FIRST SHOT DROP OFF DELAY PARAMETER

This parameter sets the amount of time after the last shot before the *FSD COMP* is used on the next shot. The first shot after powering on the Etek3 will always have *FSD COMP*. This parameter can be set between 30 and 240 seconds in 10 second increments.

LIGHT

THE LIGHT PARAMETER

The LCD backlight is illuminated whenever any of the buttons are pressed on the Etek3. The *LIGHT* parameter is used to set the amount of time that the backlight stays lit between 0.0 and 20.0 seconds in 0.5 second increments.

SLEEP

THE SLEEP PARAMETER

If the Etek3 is inactive for a period of time then it will automatically switch off in order to save power. The *SLEEP* parameter is used to set that time between 5 and 60 minutes in 5 minute increments.



QUICK GUIDE

CONTENTS
QUICK SET-UP
ORIENTATION
USING YOUR ETEK3
ADVANCED SET-UP
EMORTAL BOARD
MAINTENANCE
UPGRADING
FAULT FINDING
SERVICE CENTERS
PARTS LIST
SPARES & ACCESSORIES
INDEX

EMORTAL BOARD

FILTER

THE FILTER MENU

The parameters on the Filter Menu are all used to tune the Etek3's software filters which prevent the Etek3 from firing unless all of the necessary conditions are met. The factory default settings will be suitable for most set-ups, however certain loader and trigger set-ups may require modification of one or more of these parameters:

DBOUNCE

THE DEBOUNCE PARAMETER

The *DBOUNCE* parameter is used to combat any trigger bounce that might occur in the Etek3 and can be set between level 1 and level 9 in one level increments.

> **LEVEL 9:** Level 9 providing the most filtering.



> **LEVEL 1:** Level 1 providing the least filtering.

> **CANCEL:** Cancel editing and leave the parameter unchanged.



EMPTY

THE EMPTY BREECH TIME PARAMETER

In order for the BBSS to function correctly it must first detect that the bolt is fully retracted and the breech is empty, and then detect that a paintball is loaded into the breech before the Etek3 is allowed to fire.

Slots or holes in some third party bolts can fool the BBSS and so this parameter is used to specify a minimum time that the breech must be empty. The parameter can be set between 1.0 and 10.0ms in 0.5ms increments.



FULL

THE FULL PARAMETER

Tumbling paintballs can take time to settle in the breech before they can be successfully fired. This parameter is used to set the amount of time that a paintball has to be in the breech before the Etek3 is allowed to fire. This parameter can be set between 1.0 and 20 milliseconds in 0.5ms increments.



PULL TM

THE PULL TIME PARAMETER

The *PULL TM* parameter is used to set the minimum amount of time that the trigger must be pulled before it is recognised as a valid trigger pull. This parameter can be set between 1.0 and 20.0 milliseconds in 0.5 ms increments.



REL TM

THE RELEASE TIME PARAMETER

The *REL TM* parameter is used to set the minimum amount of time that the trigger must be released before it is recognised as a valid trigger release. This parameter can be set between 3.0 and 25.0 milliseconds in 0.5 ms increments.





QUICK GUIDE

CONTENTS

QUICK SET-UP

ORIENTATION

USING YOUR ETEK3

ADVANCED SET-UP

EMORTAL BOARD

MAINTENANCE

UPGRADING

FAULT FINDING

SERVICE CENTERS

PARTS LIST

SPARES & ACCESSORIES

INDEX

EMORTAL BOARD

CLEANING THE BREAK BEAM SENSOR SYSTEM

Undo the retaining screw for the break beam sensor cover on the left hand side of the Etek3 using a 5/64" (2mm) hex key (SEE FIGURE 13.1).

Remove the sensor cover to expose the back of the break beam sensor unit (SEE FIGURE 13.2). Using a dry cotton bud, carefully remove any debris, paint or moisture from the back of the sensor unit and from inside the sensor cover.

Lift the BBSS free from the Etek3 body and using another dry cotton bud, remove any grease or debris build-up from the front of the sensor unit (SEE FIGURE 13.3).

⚠ WARNING //

WARNING: DE-GAS YOUR MARKER, DISCHARGING ANY STORED GAS IN A SAFE DIRECTION, AND REMOVE THE BARREL, LOADER, AIR SYSTEM AND ANY PAINTBALLS TO MAKE THE MARKER EASIER AND SAFER TO WORK ON.



FIG 13.1



FIG 13.2



FIG 13.3

(CONTINUED)

Remove the rubber detent, inspect the condition of the rubber finger and replace if necessary, then using a dry cotton bud clean the detent and it's location point in the Etek3 Body. (SEE FIGURE 13.4) Replace the detent back into the Etek3 body (SEE FIGURE 13.5) and place the BBSS back into the designated slot in the body, ensuring that the receiver sensor (indicated by a red mark & red heat shrink) is located on the right-hand side of the marker body (SEE FIGURE 13.2). Ensure that the sensor is face down in the body i.e. looking into the breech.

Replace the sensor cover and using a 5/64" hex key, replace the bream beam sensor cover retaining screw to hold the sensor cover in place (SEE FIGURE 13.6).

Repeat the procedure for the opposite side of the Etek3.

You have now cleaned your break beam sensor system.



FIG 13.4



FIG 13.5



FIG 13.6

⚠ WARNING //
WARNING: IF YOU ARE AT ALL UNSURE OF PERFORMING
THE MAINTENANCE PROCEDURE PLEASE CONTACT
YOUR NEAREST ECLIPSE SERVICE CENTRE. (SEE PAGES
80-81)

QUICK GUIDE

CONTENTS
QUICK SET-UP
ORIENTATION
USING YOUR ETEK3
ADVANCED SET-UP
EMORTAL BOARD
MAINTENANCE
UPGRADING
FAULT FINDING
SERVICE CENTERS
PARTS LIST
SPARES & ACCESSORIES
INDEX

MAINTENANCE

CLEANING THE INLINE REGULATOR

Disconnect the macroline hosing from your inline regulator allowing it to be unscrewed from the front regulator mount (FRM) (SEE FIGURE 14.1).

Turn the inline regulator upside down and carefully unscrew the two sections (SEE FIGURE 14.2). These can be unscrewed by hand or using a 3/8 hex key in the top and a 5/16 hex key in the bottom of the inline regulator.

By firmly gripping the exposed end of the inline regulator piston, carefully remove the piston and spring in its entirety (SEE FIGURE 14.3).

Insert a 1/8" hex key into the adjuster screw in the bottom half of the inline regulator, and wind the screw clockwise through the bottom section of the regulator body (SEE FIGURE 14.4) and pull free when it will no longer turn upwards anymore.

The adjuster screw can only be removed by turning it upwards through the bottom section of the inline regulator. The regulator will become damaged if the adjuster screw is removed incorrectly.

Using a dry cotton bud, clean the O11 NBR 70 o-ring² that sits inside the top of the bottom section of the inline regulator (SEE OVERLEAF FIGURE 14.5). Using Eclipse Grease and a fresh cotton bud, re-lubricate the seal ready for re-assembly.

⚠ WARNING //////////////////////////////////////

WARNING: DE-GAS YOUR MARKER, DISCHARGING ANY STORED GAS IN A SAFE DIRECTION, AND REMOVE THE BARREL, LOADER, AIR SYSTEM AND ANY PAINTBALLS TO MAKE THE MARKER EASIER AND SAFER TO WORK ON.



FIG 14.1



FIG 14.2



FIG 14.3



FIG 14.4

(CONTINUED)

Thoroughly clean the two 008 NBR 70 o-rings² on the adjuster screw and lubricate ready for re-assembly. Inspect the top face of the adjuster unit for any excessive wear or damage as this could cause the inline regulator to creep (SEE FIGURE 14.6). Also inspect the inline regulator piston sealing face, if this is worn or damaged this can also cause the regulator to creep or "supercharge".

With the threaded section towards the base of the regulator body, re-insert the adjuster screw into the bottom half of the regulator body (SEE FIGURE 14.7). Apply light pressure to the top of the adjuster screw and using a 1/8" hex key wind the adjuster screw counter-clockwise until it stops at the base of the regulator body. Turn the adjuster screw 4 turns in a clockwise direction to set the inline regulator pressure at approximately 160 psi.

Take the piston and spring and clean the seal at the top of the piston², re-lubricating it with a light smear of Eclipse Grease ready for re-assembly (SEE FIGURE 14.8). Insert the piston and spring into the top half of the inline regulator body (SEE FIGURE 14.9).

The spring in the Etek3 Inline Regulator has been designed specifically for the Eclipse Etek3. Using any other spring will damage the Etek3 and void your warranty.

Keeping the top half of the inline regulator upside down, screw the two halves of the inline regulator together (SEE FIGURE 14.10).

You have now stripped, cleaned, lubricated and assembled your inline regulator.

¹The internals of your inline regulator may vary according to the model of Etek3 that you have.

²If any O-rings are damaged then replace them.

Extra o-rings are available in parts kits available online at WWW.PLANETECLIPSE.COM



FIG 14.5



FIG 14.6

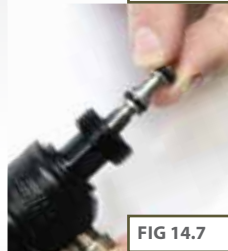

FIG 14.7



FIG 14.8



FIG 14.9



FIG 14.10

⚠ WARNING //

WARNING: IF YOU ARE AT ALL UNSURE OF PERFORMING THE MAINTENANCE PROCEDURE PLEASE CONTACT YOUR NEAREST ECLIPSE SERVICE CENTRE. (SEE PAGES 80-81)

QUICK GUIDE

CONTENTS
QUICK SET-UP
ORIENTATION
USING YOUR ETEK3
ADVANCED SET-UP
EMORTAL BOARD
MAINTENANCE
UPGRADING
FAULT FINDING
SERVICE CENTERS
PARTS LIST
SPARES & ACCESSORIES
INDEX

MAINTENANCE

CLEANING THE LOW PRESSURE REGULATOR (LPR)

1

The inline regulator can be removed if needs be.

Unscrew the LPR cap from the marker body (SEE FIGURE 11.1).

Remove the LPR piston and rear spring from the LPR cap (SEE FIGURE 11.2).

Cupping the palm of one hand, turn the LPR cap upside down and tip the front spring out into your palm (SEE FIGURE 11.3).

Remove the rear spring from the LPR piston and using a dry cotton bud, carefully clean the O13 NBR 70 o-ring on the LPR piston (SEE FIGURE 11.4). If the seal is damaged then replace it. Once the seal has been cleaned, lubricate with a light application of Eclipse Grease so that it is ready for re-assembly.

⚠ WARNING //////////////////////////////////////

WARNING: DE-GAS YOUR MARKER, DISCHARGING ANY STORED GAS IN A SAFE DIRECTION, AND REMOVE THE BARREL, LOADER, AIR SYSTEM AND ANY PAINTBALLS TO MAKE THE MARKER EASIER AND SAFER TO WORK ON.



FIG 11.1



FIG 11.2

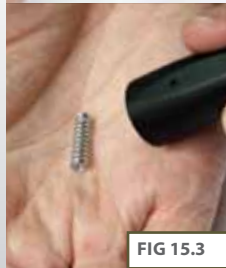

FIG 11.3



FIG 11.4

(CONTINUED)

Insert the front spring (silver in colour) into the LPR cap, so that it rests neatly on the adjuster screw² (SEE FIGURE 11.5).

Place the gold coloured spring onto the LPR piston and insert piston and spring into the LPR cap, o-ring end first (SEE FIGURE 11.6).

Before screwing the LPR cap back onto your Etek3, use a dry cotton bud to clean the O10 NBR 70 o-ring inside the LPR body (SEE FIGURE 11.7). Lubricate this seal using Eclipse Grease

Replace the LPR cap by screwing it onto the LPR body in the Etek3 (SEE FIGURE 11.8).



⚠ WARNING //

WARNING: IF YOU ARE AT ALL UNSURE OF PERFORMING THE MAINTENANCE PROCEDURE PLEASE CONTACT YOUR NEAREST ECLIPSE SERVICE CENTRE. (SEE PAGES 80-81)

¹The internals of your LPR may vary according to the model of Etek3 you have.

²The adjuster screw does not need to be removed from the LPR cap for regular maintenance.

QUICK GUIDE

CONTENTS
QUICK SET-UP
ORIENTATION
USING YOUR ETEK3
ADVANCED SET-UP
EMORTAL BOARD
MAINTENANCE
UPGRADING
FAULT FINDING
SERVICE CENTERS
PARTS LIST
SPARES & ACCESSORIES
INDEX

MAINTENANCE



MAINTAINING THE RAMMER

Pull the bolt pin upwards so that it disengages the rammer, allowing the bolt to be removed via the rear of the Etek3 (SEE FIGURE 16.1).

Using a 3/16" hex key, unscrew and remove the rammer cap at the rear of the Etek3 (SEE FIGURE 16.2).

Raise the front of the Etek3 and tap the Etek3 onto your hand until the rammer falls into the palm of your hand (SEE FIGURE 16.3).

Thoroughly clean the rammer shaft and all of its seals¹, paying special attention to the O09 NBR 70 o-ring on the middle of the shaft (SEE FIGURE 16.4), the rear O11 NBR 70 o-ring (SEE FIGURE 16.5) and the condition of the rammer bumper cushion in the rammer cap (SEE FIGURE 16.6 OVERLEAF).

Replace any worn seals/bumpers using authentic Eclipse Etek3 spare parts.

▲ WARNING //

WARNING: DE-GAS YOUR MARKER, DISCHARGING ANY STORED GAS IN A SAFE DIRECTION, AND REMOVE THE BARREL, LOADER, AIR SYSTEM AND ANY PAINTBALLS TO MAKE THE MARKER EASIER AND SAFER TO WORK ON.



FIG 16.1



FIG 16.2



FIG 16.3

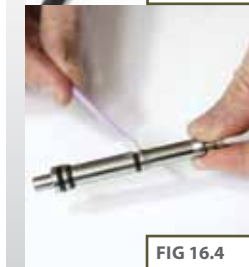

FIG 16.4



FIG 16.5

(CONTINUED)

Lubricate all of the seals on the rammer shaft and inside the rammer cap and replace the rammer into the rear of the Etek3 body as shown in (SEE FIGURE 16.7).

DO NOT use Eclipse Grease on the rammer. Only use light paintgun oil, we recommend Eclipse Gun Oil.

Replace the rammer cap, using the 3/16" hex key to secure it into the Etek3 body (SEE FIGURE 16.8).

DO NOT over tighten the rammer cap screw.

Noting the position of the rammer in the Etek3 body (SEE FIGURE 16.9), replace the bolt and locate the bolt pin into the designated groove in the rammer shaft using the dot on the bolt as a reference guide (SEE FIGURE 16.10).



FIG 16.6



FIG 16.7



FIG 16.8



FIG 16.9



DOT

FIG 16.10

⚠ WARNING //

WARNING: IF YOU ARE AT ALL UNSURE OF PERFORMING THE MAINTENANCE PROCEDURE PLEASE CONTACT YOUR NEAREST ECLIPSE SERVICE CENTRE. (SEE PAGES 80-81)

¹The number of o-rings on the rammer may vary according to the model of Etek3 that you have.

QUICK GUIDE

CONTENTS
QUICK SET-UP
ORIENTATION
USING YOUR ETEK3
ADVANCED SET-UP
EMORTAL BOARD
MAINTENANCE
UPGRADING
FAULT FINDING
SERVICE CENTERS
PARTS LIST
SPARES & ACCESSORIES
INDEX

MAINTENANCE



CLEANING AND LUBRICATING THE BOLT

Raise the bolt pin and remove the bolt and bolt pin from the Etek3 marker body (FIGURE 17.1).

Using a dry cotton bud remove any paint or grease from the surface of the bolt (SEE FIGURE 17.2).

Lubricate the detent slots on either side of the bolt with gun oil, ensuring that a drop of oil is placed on the o-rings at the point where they cross the detent slots (SEE FIGURE 17.3). Replace the bolt, locking the bolt pin into the designated slot in the rammer using the dot on the bolt as a reference guide (SEE FIGURE 17.4).

We recommend the use of Eclipse Gun Oil on the Etek3 rammer and bolt.

⚠ WARNING //

WARNING: DE-GAS YOUR MARKER, DISCHARGING ANY STORED GAS IN A SAFE DIRECTION, AND REMOVE THE BARREL, LOADER, AIR SYSTEM AND ANY PAINTBALLS TO MAKE THE MARKER EASIER AND SAFER TO WORK ON.

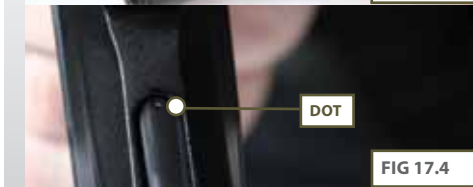

REMOVING AND ATTACHING THE FRAME

Disconnect any hosing and unscrew the inline regulator from the front regulator mount as detailed in the *Cleaning the Inline Regulator* section of this maintenance guide (pages 56-57).

Using a 5/64" hex key remove the six screws that attach the Etek3 rubber grips to the Etek3 grip frame (SEE FIGURE 18.1). Unplug the solenoid and unplug the break beam sensor system from their connections on the Etek3 circuit board (SEE FIGURE 18.2).

Using a 1/8" hex key undo the two frame retaining screws (SEE FIGURE 18.3) and remove the frame from the Etek3 body, taking care not to damage any wires (SEE FIGURE 18.4).

You have now removed the frame.

⚠ WARNING //

WARNING: DE-GAS YOUR MARKER, DISCHARGING ANY STORED GAS IN A SAFE DIRECTION, AND REMOVE THE BARREL, LOADER, AIR SYSTEM AND ANY PAINTBALLS TO MAKE THE MARKER EASIER AND SAFER TO WORK ON.



QUICK GUIDE

CONTENTS
QUICK SET-UP
ORIENTATION
USING YOUR ETEK3
ADVANCED SET-UP
EMORTAL BOARD
MAINTENANCE
UPGRADING
FAULT FINDING
SERVICE CENTERS
PARTS LIST
SPARES & ACCESSORIES
INDEX

MAINTENANCE

(CONTINUED)

To re-attach the frame follow the instructions below.

Carefully thread the solenoid and break beam sensor system wires through the access holes in the top of the Etek3 grip frame (SEE FIGURE 18.5) and re-attach the grip frame to the marker body by tightening the two grip frame screws using a 1/8" hex key (SEE FIGURE 18.6).

Ensure that the break beam sensor system cables lie neatly in the slots provided for them on the inside of the Etek3 grip frame and connect the solenoid and the break beam sensors to their relevant connections on the Etek3 circuit board (SEE FIGURE 18.7). Adjust both the solenoid wires and the break beam sensor system wires so that they sit neatly within the grip frame away from the micro-switch arm (SEE FIGURE 18.8).

Re-attach the Etek3 rubber grips to the frame by using a 5/64" hex key to replace the 6 grip screws.



FIG 18.5



FIG 18.6



FIG 18.7



FIG 18.8

⚠ WARNING //

WARNING: IF YOU ARE AT ALL UNSURE OF PERFORMING THE MAINTENANCE PROCEDURE PLEASE CONTACT YOUR NEAREST ECLIPSE SERVICE CENTRE. (SEE PAGES 80-81)

THE ETEK3 TRIGGER ASSEMBLY

Having removed the trigger frame completely from the Etek3 body (see page 63), remove the retaining clip that holds the bearing carrier in place in the top of the frame, this is best done using some pointed nose pliers to pinch the clip and lift free from the frame (**SEE FIGURE 19.1**). Gently lift the bearing carrier and trigger assembly free from the frame taking care not to damage the micro-switch (**SEE FIGURE 19.2**).

Using a 1/16" hex key, loosen the trigger pin retaining set screw in the back of the trigger (**SEE FIGURE 19.3**). Use a small hex key to push the trigger pin out of the bearing carrier from one side (**SEE FIGURE 19.4**).

Clean the trigger and bearing carrier thoroughly and also clean the space within the frame that the trigger sits into.

⚠ WARNING //
WARNING: DE-GAS YOUR MARKER, DISCHARGING ANY STORED GAS IN A SAFE DIRECTION, AND REMOVE THE BARREL, LOADER, AIR SYSTEM AND ANY PAINTBALLS TO MAKE THE MARKER EASIER AND SAFER TO WORK ON.



FIG 19.1



FIG 19.2



FIG 19.3



FIG 19.4

QUICK GUIDE

CONTENTS
QUICK SET-UP
ORIENTATION
USING YOUR ETEK3
ADVANCED SET-UP
EMORTAL BOARD
MAINTENANCE
UPGRADING
FAULT FINDING
SERVICE CENTERS
PARTS LIST
SPARES & ACCESSORIES
INDEX

MAINTENANCE

(CONTINUED)

Position the trigger so that the hole through the trigger lines up with the holes in the bearing carrier (SEE FIGURE 19.5) Then slide the trigger pin in place, tighten the trigger pin locking screw in the back of the trigger ensuring that the trigger can still move freely in the bearing carrier. Gently lower the trigger assembly and bearing carrier into the frame, taking care not to damage the micro-switch and ensuring that the trigger is positioned correctly (SEE FIGURE 19.6). Then insert the retaining clip into the frame on top of the bearing carrier, ensuring the legs of the clip are sat in the locating holes in the frame wall.(SEE FIGURE 19.7).

You have now stripped and cleaned your Etek3 trigger assembly.



FIG 19.5



FIG 19.6

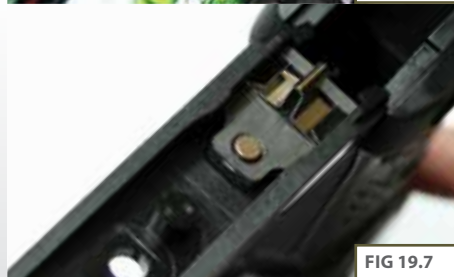

FIG 19.7

⚠ WARNING //
WARNING: IF YOU ARE AT ALL UNSURE OF PERFORMING THE MAINTENANCE PROCEDURE PLEASE CONTACT YOUR NEAREST ECLIPSE SERVICE CENTRE. (SEE PAGES 80-81)

THE ETEK3 SOLENOID ASSEMBLY

With the frame separated from the Etek3 body and the solenoid assembly and BBSS assembly unplugged from the circuit board (see page 63) (SEE FIGURE 20.1), use a small Phillips head screw driver to undo and remove the two M1.6x16 screws that hold the solenoid assembly onto the solenoid manifold (SEE FIGURE 20.2).

Removing the solenoid will completely reveal the solenoid manifold (SEE FIGURE 20.3), using a 5/64 hex key remove all three M2.5x6 screws which hold the manifold to the Etek3 body (SEE FIGURE 20.4).

With the solenoid assembly completely removed from the Etek3 body the bottom of the Etek3 body should now resemble FIGURE 20.5. Ensure that the air transfer holes in the bottom of the body are free from contamination from any dirt, debris, paint or moisture and clear away any excess grease if it appears to be blocking any of the transfer holes.

Check the top and bottom of the solenoid manifold to ensure that it is also free from damage or debris (SEE FIGURE 20.5). Remove and clean the rubber gaskets as shown in FIGURE 20.6. Replace the rubber gaskets ensuring that they lie flat in their designated grooves in the solenoid manifold body.

Re-attach the solenoid manifold to the Etek3 body with the three M2.5x6 screws.

⚠ WARNING ///
WARNING: DE-GAS YOUR MARKER, DISCHARGING ANY STORED GAS IN A SAFE DIRECTION, AND REMOVE THE BARREL, LOADER, AIR SYSTEM AND ANY PAINTBALLS TO MAKE THE MARKER EASIER AND SAFER TO WORK ON.



FIG 20.1



FIG 20.2



FIG 20.3



FIG 20.4



FIG 20.5



FIG 20.6



FIG 20.7

QUICK GUIDE

CONTENTS
QUICK SET-UP
ORIENTATION
USING YOUR ETEK3
ADVANCED SET-UP
EMORTAL BOARD
MAINTENANCE
UPGRADING
FAULT FINDING
SERVICE CENTERS
PARTS LIST
SPARES & ACCESSORIES
INDEX

MAINTENANCE

(CONTINUED)

With the solenoid detached from the manifold, use a small flat instrument to gently lever the two solenoid retainer clips off the solenoid (SEE FIGURE 20.7). This will allow you to split the solenoid into two and access the spool valve.

Using a pair of needle-nose pliers remove the spool shaft from the main section of the solenoid (SEE FIGURE 20.8). Note that it is the flat side of the spool shaft that is facing you when you remove the spool shaft. It may be necessary to also remove the front cap of the solenoid to push the shaft out, if it cannot be pulled out with the needle nose pliers.

Thoroughly clean and inspect the spool shaft and its O-rings for any debris or dirt (SEE FIGURE 20.9). Lubricate the o-rings using Eclipse Grease or DOW 33 Lubricant and re-insert the spool shaft into the solenoid body, insuring that the concave end goes in first.

FIGURE 20.10 and **FIGURE 20.11** show the difference between the flat end of the spool shaft and the concave end.

Ensure the solenoid manifold is attached to the Etek3 body before attempting to attach the solenoid.

Replace the two solenoid retaining clips to the sides of the solenoid body. Then having ensured that the small manifold gasket is in place; screw the solenoid back into the correct position on the manifold. For reference, the pilot end of the solenoid with the metal casing should be towards the front of the marker.

You have now stripped and cleaned your Etek3 solenoid.



FIG 20.8



FIG 20.9



FIG 20.10



FIG 20.11



FIG 20.12

⚠ WARNING //////////////////////////////////////
WARNING: IF YOU ARE AT ALL UNSURE OF PERFORMING THE MAINTENANCE PROCEDURE PLEASE CONTACT YOUR NEAREST ECLIPSE SERVICE CENTRE. (SEE PAGES 80-81)

MAINTAINING THE VALVE ASSEMBLY

Lift the bolt pin and slide the bolt out of the rear of the marker. Disconnect any hosing and unscrew the inline regulator from the front regulator mount as detailed in the *Cleaning the Inline Regulator* section of this maintenance guide (page 54-55). Remove the frame as detailed on page 61.

Take the Etek3 body and turn it so that the underside of the solenoid assembly, and valve plug are visible and accessible. Using a 1/8" hex key remove the screw from the front regulator mount that holds the LPR body in the marker body (**SEE FIGURE 21.1**).

Remove the entire LPR assembly, the valve spring and the exhaust valve from the marker body (**SEE FIGURE 21.2**). Using a 1/8" hex key remove the valve plug from the underside of the Etek3 body (**SEE FIGURE 21.3**). The bottom of the rammer housing should now be visible through the valve plug hole (**SEE FIGURE 21.4**). Ensure that the rammer is in its rear position and taking an L-shaped hex key, place it down through the bolt slot in the top of the body so that you can apply light pressure to the end of the rammer and push it backwards along with the rammer housing out the back of the Etek3 body (**SEE FIGURE 21.5 AND 21.6**).

⚠ WARNING //

WARNING: DE-GAS YOUR MARKER, DISCHARGING ANY STORED GAS IN A SAFE DIRECTION, AND REMOVE THE BARREL, LOADER, AIR SYSTEM AND ANY PAINTBALLS TO MAKE THE MARKER EASIER AND SAFER TO WORK ON.



QUICK GUIDE

CONTENTS
QUICK SET-UP
ORIENTATION
USING YOUR ETEK3
ADVANCED SET-UP
EMORTAL BOARD
MAINTENANCE
UPGRADING
FAULT FINDING
SERVICE CENTERS
PARTS LIST
SPARES & ACCESSORIES
INDEX

MAINTENANCE

(CONTINUED)

Inspect the sealing face of both the rammer housing (**SEE FIGURE 21.7**) and the exhaust valve (**SEE FIGURE 21.8**) for any excessive wear or damage. If either the exhaust valve or the rammer housing are damaged then replace with authentic Etek3 parts.

Clean and lubricate all of the o-rings on the rammer housing with Eclipse Gun Oil paying particular attention to the front two around the outlet port on the rammer housing (**SEE FIGURE 21.9**).

Insert the rammer housing back into the Etek3 body ensuring that the outlet port is facing upwards and the valve plug hole is facing downwards (**SEE FIGURE 21.10**). Slide the rammer housing all the way into the Etek3 body until the rammer cap nears the back of the body.

Looking on the underside of the Etek3 body carefully line up the hole in the body and rammer housing which accommodates the valve plug screw (**SEE FIGURE 21.11**).

Then take a 1/8" hex key and replace and tighten down the valve plug screw (**SEE FIGURE 21.12**).



FIG 21.7



FIG 21.8



FIG 21.9

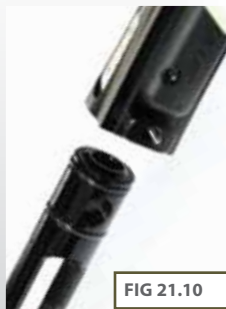

FIG 21.10



FIG 21.11

(CONTINUED)

Using Eclipse Gun Oil lubricate the LPR body o-rings (SEE FIGURE 21.13).

Take the exhaust valve and insert the white end into the valve spring, and the other end of the valve spring into the back of the LPR body (creating a stack of parts) (SEE FIGURE 21.14).

Take the stack and insert it into the valve chamber bore of the Etek3 body, exhaust valve first (SEE FIGURE 21.15).

When inserted, line up the holes in the LPR body with the FRM screw hole in the Etek3 body (SEE FIGURE 21.16).

Insert and tighten down the FRM screw using a 1/8" hex key (SEE FIGURE 21.17).

Attach the Etek3 frame (See page 62).

You have now stripped and cleaned your Etek3 Exhaust Valve Assembly.



QUICK GUIDE

CONTENTS
QUICK SET-UP
ORIENTATION
USING YOUR ETEK3
ADVANCED SET-UP
EMORTAL BOARD
MAINTENANCE
UPGRADING
FAULT FINDING
SERVICE CENTERS
PARTS LIST
SPARES & ACCESSORIES
INDEX

MAINTENANCE



THE ETEK3 ON/OFF PURGE SYSTEM (OOPS)

Having disconnected the macroline hose from the fitting on the OOPS body, unscrew the OOPS knob from the OOPS body (**SEE FIGURE 22.1**). Clean off any dirt, debris or moisture from the OOPS knob and the threaded section of the OOPS body.

Use an appropriately sized hex key to push the OOPS pin out of the OOPS body (**SEE FIGURE 22.2**) and then remove the OOPS insert using a pair of needle nosed pliers (**SEE FIGURE 22.3**).

Clean and check the condition of the two 008 NBR70 o-rings on the outside of the OOPS insert, replacing as necessary (**SEE FIGURE 22.4**).

⚠ WARNING //

WARNING: DE-GAS YOUR MARKER, DISCHARGING ANY STORED GAS IN A SAFE DIRECTION, AND REMOVE THE BARREL, LOADER, AIR SYSTEM AND ANY PAINTBALLS TO MAKE THE MARKER EASIER AND SAFER TO WORK ON.



FIG 22.1



FIG 22.2



FIG 22.3

FIG 22.4

(CONTINUED)

Clean and check the condition of the single internal 006 NBR90 o-ring in the front of the OOPS insert, replace if necessary (SEE FIGURE 22.5). Lubricate all three of these o-rings liberally using Eclipse Grease (SEE FIGURE 22.6).

Replace the OOPS insert into the OOPS body ensuring that the o-ring end goes in first, pushing it into place (SEE FIGURE 22.7).

Lubricate the narrow end of the OOPS pin with a smear of Eclipse Grease and push the pin, narrow end first, into the OOPS body so that it sits in the OOPS insert and pokes through the front of the OOPS body (SEE FIGURE 22.8).

Screw the OOPS knob back onto the OOPS body until only a couple of threads are showing (SEE FIGURE 22.9).

Reconnect the macroline hose to the fitting on the OOPS body (SEE FIGURE 22.10).

You have now successfully cleaned and maintained your On/Off purge system.



FIG 22.5

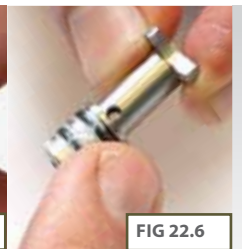

FIG 22.6



FIG 22.7



FIG 22.8



FIG 22.9



FIG 22.10

⚠ WARNING //

WARNING: IF YOU ARE AT ALL UNSURE OF PERFORMING THE MAINTENANCE PROCEDURE PLEASE CONTACT YOUR NEAREST ECLIPSE SERVICE CENTRE. (SEE PAGES 80-81)

QUICK GUIDE

CONTENTS
QUICK SET-UP
ORIENTATION
USING YOUR ETEK3
ADVANCED SET-UP
EMORTAL BOARD
MAINTENANCE
UPGRADING
FAULT FINDING
SERVICE CENTERS
PARTS LIST
SPARES & ACCESSORIES
INDEX

MAINTENANCE

INSTALLING THE LT UPGRADE KIT

The Etek3 LT can be upgraded to an all metal Etek3 by purchasing the 'Etek3 LT Upgrade Kit'.

On the following pages are instructions on how to install these parts.

INSTALLING THE FEED NECK

Remove the loader from the Etek3 (**SEE FIGURE 23.1**).

Remove the retaining screw from the feedneck using a 5/32" hex key (**SEE FIGURE 23.2**).

With the retaining screw removed, slide the feedneck off the Etek3 body (**SEE FIGURE 23.3**).

Loosen the retaining screw on the new metal feedneck with a 5/32" hex key, then slide this onto the Etek3 body (**SEE FIGURE 23.4**).

Line up the feedneck with the screws towards the back of the Etek3 (**SEE FIGURE 23.5**) and tighten the retaining screw at the bottom of the feedneck. This clamps the feedneck to your Etek3 (**SEE FIGURE 23.6**).

You have now attached your new metal feed neck.

⚠ WARNING //

WARNING: DE-GAS YOUR MARKER, DISCHARGING ANY STORED GAS IN A SAFE DIRECTION, AND REMOVE THE BARREL, LOADER, AIR SYSTEM AND ANY PAINTBALLS TO MAKE THE MARKER EASIER AND SAFER TO WORK ON.



FIG 23.1



FIG 23.2



FIG 23.3



FIG 23.4

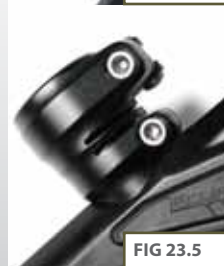

FIG 23.5

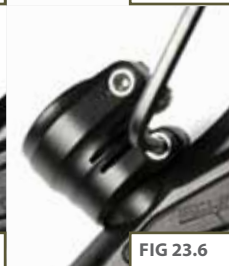

FIG 23.6

(CONTINUED)

INSTALLING THE FRAME

To install a upgrade metal frame to your Etek3 LT first remove your GRN frame. See Removing and Attaching the Frame on page 61-62. Next remove the battery (See page 10 on Installing a 9V Battery).

Remove the OOPS from the GRN frame by loosening the two retaining screws with a 3/32" hex key (SEE FIGURE 24.1). Then slide the OOPS off the T-slot.

Remove the trigger assembly from the GRN frame as detailed in 'The Etek3 Trigger Assembly' section of the maintenance chapter (See page 63-64).

Remove the trigger retaining clip that holds the micro-switch in place on the frame (SEE FIGURE 24.2), then unplug the micro-switch from the Etek3 circuit board. Slide the circuit board and clips out of the frame (SEE FIGURE 24.3).

Screw the micro-switch into place on the metal frame using the two Phillips M2x10 screws provided (SEE FIGURE 24.4).

Install the trigger assembly into the metal frame as covered in 'The ETEK3 Trigger Assembly' (See page 63-64).

If the Emortal board is also being installed at this point please turn to page 75 - 'Installing the Emortal Board'.

Attach the circuit board retaining clips to the Etek3 circuit board, ensuring when inserting it into the frame that the clips are in the correct orientation as shown in FIGURE 24.5. Slide the circuit board and retaining clips into the metal frame (SEE FIGURE 24.6).

Insert and connect the battery (See page 10).

Slide the OOPS onto the metal frame and tighten down the retaining screws using a 3/32" hex key.

Attach the frame to the Etek3 body as covered on page 62



FIG 24.1



FIG 24.2



FIG 24.3



FIG 24.4

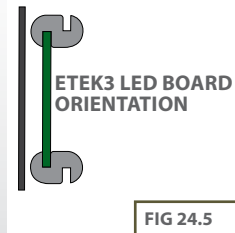

FIG 24.5



FIG 24.6

⚠ WARNING //
WARNING: IF YOU ARE AT ALL UNSURE OF PERFORMING THE MAINTENANCE PROCEDURE PLEASE CONTACT YOUR NEAREST ECLIPSE SERVICE CENTRE. (SEE PAGES 80-81)

QUICK GUIDE

CONTENTS
QUICK SET-UP
ORIENTATION
USING YOUR ETEK3
ADVANCED SET-UP
EMORTAL BOARD
MAINTENANCE
UPGRADING
FAULT FINDING
SERVICE CENTERS
PARTS LIST
SPARES & ACCESSORIES
INDEX

UPGRADING

(CONTINUED)

INSTALLING THE EYE COVERS

To install upgrade metal eye covers in place of the LT GRN ones (**SEE FIGURE 25.1**) firstly remove the GRN eye covers as detailed on page 52-53 'Cleaning the Break Beam sensor System'.

Follow these same instructions for attaching the new metal eye covers.

⚠ WARNING //

WARNING: DE-GAS YOUR MARKER, DISCHARGING ANY STORED GAS IN A SAFE DIRECTION, AND REMOVE THE BARREL, LOADER, AIR SYSTEM AND ANY PAINTBALLS TO MAKE THE MARKER EASIER AND SAFER TO WORK ON.



⚠ WARNING //

WARNING: IF YOU ARE AT ALL UNSURE OF PERFORMING THE MAINTENANCE PROCEDURE PLEASE CONTACT YOUR NEAREST ECLIPSE SERVICE CENTRE. (SEE PAGES 80-81)

INSTALLING THE EMORTAL BOARD (AM AND UPGRADE METAL LT FRAMES ONLY)

Open up the frame by unscrewing the three grip screws with a 5/64" hex key. (SEE FIGURE 26.1)

Unplug all 3 connectors from the circuit board. (SEE FIGURE 26.2)

Unplug and remove the battery. See page 10 on 'Installing a 9V Battery' for instructions on how to do this. (SEE FIGURE 26.3)

Slide the LED board out of the frame along with the retainers. (SEE FIGURE 26.4)

Using a hex key or finger push the LED navigation console out of the frame from the back through the window in the frame (SEE FIGURE 26.5). Leave the plastic push button strip in the back of the frame. (SEE FIGURE 26.6)

⚠ WARNING //
WARNING: DE-GAS YOUR MARKER, DISCHARGING ANY STORED GAS IN A SAFE DIRECTION, AND REMOVE THE BARREL, LOADER, AIR SYSTEM AND ANY PAINTBALLS TO MAKE THE MARKER EASIER AND SAFER TO WORK ON.



FIG 26.1



FIG 26.2



FIG 26.3



FIG 26.4

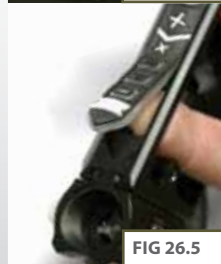

FIG 26.5



FIG 26.6

QUICK GUIDE

CONTENTS
QUICK SET-UP
ORIENTATION
USING YOUR ETEK3
ADVANCED SET-UP
EMORTAL BOARD
MAINTENANCE
UPGRADING
FAULT FINDING
SERVICE CENTERS
PARTS LIST
SPARES & ACCESSORIES
INDEX

UPGRADING

(CONTINUED)

Take the Emortal Board Navigation Console and peel off the sticker backing. (SEE FIGURE 26.7)

Making sure the small plastic lens is still in the window at the bottom of the Navigation Console, and the push button strip is still in the back of the frame, insert the Navigation Console into the back of the frame with the window at the bottom. (SEE FIGURE 26.8)

Ensure the circuit board retainers are attached in the correct orientation to the Emortal board (SEE FIGURE 26.9). Then insert the Emortal board into the frame with the screen at the bottom of the frame.

Connect the BBSS, Solenoid and Trigger connectors to the circuit board with their corresponding sockets on the board. (SEE FIGURE 26.10)

Install a 9V battery as described on page 10. (SEE FIGURE 26.11)

Replace the three grip screws using a 5/64 hex key. (SEE FIGURE 26.12)

You have now installed the Etek3 Emortal board.

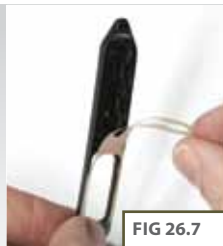
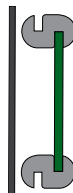

FIG 26.7



FIG 26.8



ETEK3
EMORTAL
BOARD
ORIENTATION

FIG 26.9

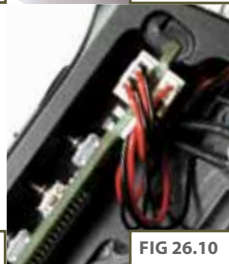

FIG 26.10



FIG 26.11

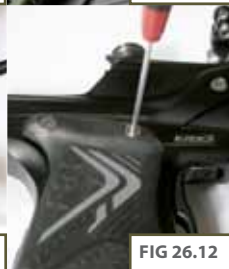

FIG 26.12

⚠ WARNING //

WARNING: IF YOU ARE AT ALL UNSURE OF PERFORMING THE MAINTENANCE PROCEDURE PLEASE CONTACT YOUR NEAREST ECLIPSE SERVICE CENTRE. (SEE PAGES 80-81)

SYMPTOM	POSSIBLE CAUSE	SOLUTION
Although a fresh battery has been fitted, the Etek3 will not switch on.	The battery has been fitted incorrectly.	Fit the battery correctly.
	The battery connector is not making proper contact with the battery.	Remove the battery, check the battery connector is clean and re-install the battery.
The battery does not seem to last very long.	The battery type is of a low quality.	Use an alkaline or lithium battery. Do not use a low quality or rechargeable battery.
The Etek3 leaks from the solenoid.	Either gasket is damaged and/or not seated correctly in its designated pocket in the manifold body.	Replace the gasket if damaged using Etek3 parts kit. Ensure the gasket is seated correctly.
	Damaged Etek3 solenoid.	Replace Etek3 solenoid.
	LPR is supercharging causing intermittent leaking.	Clean LPR piston seal.
		Inspect regulator seal (in LPR piston) and regulator seat (in LPR body). Replace if necessary.
	Solenoid Spool shaft is damaged or dirty.	Clean or replace if required.
	Damaged or incorrect seals on rammer.	Replace seals.
It is leaking from the barbs.	Check hose for cuts or replace barbs.	
The Etek3 leaks down the barrel.	Leaky exhaust valve.	Replace exhaust valve.
	Damaged rammer housing.	Replace rammer housing and o-rings.
Gas vents quickly down barrel as soon as it is gassed up.	Incorrect seal on front of rammer housing.	Replace front seals on rammer housing with 014 NBR70.
	The exhaust valve has become jammed in the rammer housing.	Replace exhaust valve and rammer housing as necessary (see Maintenance section).

QUICK GUIDE

CONTENTS

QUICK SET-UP

ORIENTATION

USING YOUR ETEK3

ADVANCED SET-UP

EMORTAL BOARD

MAINTENANCE

UPGRADING

FAULT FINDING

SERVICE CENTERS

PARTS LIST

SPARES & ACCESSORIES

INDEX

FAULT FINDING

SYMPTOM	POSSIBLE CAUSE	SOLUTION
The marker is chopping or trapping paint.	The break beam sensor system is switched off.	Switch on the break beam sensor system.
	The bolt is dirty, causing the sensor system to incorrectly detect a paintball.	Clean the bolt.
	The break beam sensor system is dirty causing the incorrect detection of paintballs.	Clean the break beam sensor system.
	The Dwell parameter is set too low.	Increase the Dwell parameter.
The Etek3 fires yet bolt doesn't move.	Bolt pin is not located in rammer correctly.	Lift bolt pin and line up with position of rammer correctly (See Maintenance section).
The Etek3 does not fire.	Trigger is set up incorrectly.	Set trigger up correctly. (See Setting the Trigger on page 23)
	Solenoid is not plugged into the Etek3 PCB.	Plug solenoid into port on the Etek3 PCB.
	The break beam sensor system is enabled but there is no paint.	Fill loader with paint.
	Micro-switch is not being activated.	Adjust front and rear travel screws accordingly.
	Micro-switch is damaged.	Replace Micro-switch.
	Solenoid valve is damaged	Replace Solenoid
Low velocity first shot.	FSD Comp parameter is too low to overcome stiction on solenoid and / or rammer O-rings.*	Increase FSD Comp parameter.
High velocity first shot.	FSD Comp parameter set too high.*	Reduce FSD Comp parameter.
	Inline regulator pressure is creeping.	Strip and clean inline regulator. Replace inline regulator piston if necessary.
The trigger very "bouncy".	Incorrect filter settings.	Check that your trigger filter and debounce settings suit your trigger set-up.
	Trigger pull too short and return magnet strength too low.	Refer to Setting the Trigger section for guidelines of how to adjust your Etek3 trigger accordingly.

SYMPTOM	POSSIBLE CAUSE	SOLUTION
The break beam sensor system does not appear to be reading correctly.	The break beam sensor system is dirty.	Keep the break beam sensors clean to ensure correct readings (See Maintenance Section).
	Break beam sensors are the wrong way around.	Check that the red receiver is on the right-hand side of the breech.
The break beam sensor system is not reading at all.	There is a broken wire or contact, or a short circuit on either of the breech sensor cables.	Check the plug of the cables. Check for cuts or pinches in the sensor cables.
	Either sensor is back to front.	Check that the sensors face each other when installed.
Two or more balls are being fed into the breech.	If the Etek3 is being used with a force feed loader, it is possible that the loader is forcing balls past the ball detent.	Change the rubber finger detent.
Etek3 is inconsistent.	Inline regulator is supercharging.	Strip and clean inline regulator. (See Maintenance section)
Leaking rammer assembly (Leak gets louder when bolt is removed).	Front rammer shaft seal deteriorated.	Replace front rammer shaft seal.
Eye turns itself off after firing.	Eye is dirty.	Clean the eyes.
	Eye is faulty.	Replace the eyes.
	Eye is out of place.	Re-Install Eyes. Check alignment.
When the Etek3 powers up, the marker enters the set up mode. (LED board) When the Etek3 powers up, no game timer / shot counter / ROF indicator is displayed and the gun will not fire.*	The trigger is permanently depressed.	Turn the front stop set screw in the top of the trigger counter-clockwise until the display reads correctly. If there is insufficient trigger adjustment then turn the magnet return force set screw counter clockwise also.
The Etek3 leaks out of the LPR body vent hole (small hole below the LPR assembly on the Etek3 body).	The two rear 14x2 o-rings on the LPR body are damaged.	Replace both rear o-rings with new 14x2 NBR70 o-rings.

* ONLY APPLIES TO ETEK3'S WITH AN EMORTAL BOARD FITTED

QUICK GUIDE

CONTENTS

QUICK SET-UP

ORIENTATION

USING YOUR ETEK3

ADVANCED SET-UP

EMORTAL BOARD

MAINTENANCE

UPGRADING

FAULT FINDING

SERVICE CENTERS

PARTS LIST

SPARES & ACCESSORIES

INDEX

FAULT FINDING



ECLIPSE CERTIFIED SERVICE CENTRES

Are you unsure of where to send your Etek3 to be repaired or serviced? If your local Eclipse dealer can't assist you, why not contact your nearest Certified Eclipse Service Centre and arrange to send it into them to undertake any work that you require.

UNITED KINGDOM & EUROPE

PLANET ECLIPSE LTD

United Kingdom

Call: +44(0)161 872 5572
Email: technical@planetecclipse.com
Visit: www.planeteclipse.com

P8NTBALL.BE

Belgium

Call: +32(0)499-057878
Email: info@p8ntball.be
Visit: www.paintball.be

AGS

Czech Republic

Call: ++420 272 762 938
Email: info@paintballshop.cz
Visit: www.paintballshop.cz

CAMP

France

Call: +33(0)1 41 09 1004
Email: atelier@paintballcamp.com
Visit: www.paintballcamp.com

COOLGAMES

Finland

Call: ++358 9 586 5312
Email: mikke@ahaa.fi
Visit: www.coolgames.fi

PAINTBALL.DE

Germany

Call: ++49(0) 211 210 2300
Email: salesforce@paintball.de
Visit: www.paintball.de

PAINTBALLNORGE AS

Norway

Call: ++47 3802 9710
Email: post@paintballnorge.no
Visit: www.paintballnorge.no

SKILL PAINTBALL

Poland

Call: ++48 22 875 2777
Email: info@skill.com.pl
Visit: www.skill.com.pl

ESTRATEGO PORTUGAL

Portugal

Call: ++351 213 863 637
Email: info@estratego.pt
Visit: www.estratego.com

PONTO DE MIRA

Portugal

Call: ++351 214 120 144
Email: paintball@pontodemira.com
Visit: www.pontodemira.com

ACTION PAINTBALL GAMES

Russia

Call: +7(0) 95 7851 762
Email: info@paintball.ru
Visit: www.paintball.ru

DOC'S TECH

Russia

Call: +7 911 9496969
Email: doc.bo@mail.ru

ADRENALICIA S.L.

Spain

Call: ++34 669 011 515
Email: jota@adrenalicia.com
Visit: www.adrenalicia.com

SISSOS

Scandinavia

Call: +358 9 85590093
Email: hasse@paintball.se
Visit: www.sissos.fi

STRATEC

Sweden

Call: +46 (0)31 164871
Email: info@stratec.nu
Visit: www.stratec.nu

THREE 4 ONE

Switzerland

Call: +41 (0)79 445 24 12
Email: shop@341.ch
Visit: www.341.ch

U.S.A.

PLANET ECLIPSE LLC

Rhode Island

Call: (401) 247 9061
Email: gerry.b@planetecclipse.com
Visit: www.planetecclipse.com

DISRUPTIVE PAINTBALL

Arizona

Call: (520) 320 0333
Email: disruptivepaintball@yahoo.com
Visit: www.disruptivepaintball.com

DGX PAINTBALL

California and West Coast

Call: (707) 255 5166
Email: Darin@dgxpaintball.com
Visit: www.dgxpaintball.com

MOUNTAIN VIEW PAINTBALL

California

Call: (909) 373 0998
Email: mvpsteve@mountainviewpaintball.com
Visit: www.mountainviewpaintball.com

EXTREME SKATE AND PAINT

Florida and South America

Call: (305) 235 2311
Fax: (305) 235 2312
Email: mikecanto1@msn.com
Email: pjballin@hotmail.com
Visit: www.espsports.net

PRO STAR PAINTBALL

Nebraska and Midwest

Call: (402) 403 1880
Email: Walt@prostarpb.com
Visit: www.prostarpb.com

PAINTBALL CENTRAL

North Carolina

Call: (336) 274 4002
Visit: www.pballcentral.com

FRONTLINE PAINTBALL

Ohio

Call: (614) 539 4440
Email: frontlinepb@sbcglobal.net
Visit: www.walltowallpaintball.com

WARPAINT INTERNATIONAL

Oregon

Call: (503) 585 9477
Email: info@warpaintpb.com

PAINTBALL SHOWCASE

Rhode Island and East Coast

Call: (401) 353 6040
Email: paintballsupply@aol.com
Visit: www.paintballshowcase.com

GROUND ZERO PAINTBALL

South Carolina and Southern States

Call: (888) 759 2578
Email: egdesigns@hughes.net
Visit: www.gzpaintball.com

PRO SHOP PAINTBALL

Texas

Call: (210) 523 5000
Email: proshoppaintball@sbcglobal.net
Visit: www.proshoppaintball.com

REST OF WORLD

ACTION PAINTBALL GAMES

Australia

Call: ++61 2 9679 0011
Email: sales@actionpaintball.com.au
Visit: www.actionpaintball.com.au

BRAZIL'S MOST WANTED PAINTBALL

Brazil

Call: 55-61-8406-5781
Fax: 55-61-3345-1664
Email: andreobarros@gmail.com
Visit: www.bmwpaintball.com

MEGA PLAY MORUMBI PAINTBALL

Brazil

Call: (11) 3771-2969
Email: paintball@megaplaymorumbi.com.br
Visit: www.megaplaymorumbi.com.br

BADLANDS PAINTBALL

Canada

Call: (416) 245 3856
Email: techzone@badlandspaintball.com
Visit: www.badlandspaintball.com

EL 2NEL

Chile

Call: (56+2) 8393852
Email: mlobos@2nel.cl
Visit: www.2nel.cl

FAST DUCKS PAINTBALL

Colombia

Call: 7119410-2382922
Email: Ariel@fastduckspaintball.com
Visit: www.fastduckspaintball.com

SKIRMISH PAINTBALL ASIA

Malaysia

Call: ++603 7722 5629
Email: info@skirmishpaintballasia.com
Visit: www.skirmishpaintballasia.com

EXTREME SPORTS MEXICO

Mexico

Cell: 619-392-8563
Call USA: 619-567-6141
Call Mexico: 664-630-8742
Email: jacuzzi9@hotmail.com

THE PAINTBALL SHOP

South Africa

Call: ++27 413640549
Email: info@paintballshop.co.za
Visit: www.paintballshop.co.za

VIPER PAINTBALL SUPPLY

Venezuela

Call: 584122060751
Email: vipertcps@hotmail.com

QUICK GUIDE

CONTENTS

QUICK SET-UP

ORIENTATION

USING YOUR ETEK3

ADVANCED SET-UP

EMORTAL BOARD

MAINTENANCE

UPGRADING

FAULT FINDING

SERVICE CENTERS

PARTS LIST

SPARES & ACCESSORIES

INDEX

SERVICE CENTERS

PARTS LIST



PART NAME

- | | | |
|------------------------------|-------------------------------------|------------------------------------|
| 01 Rammer Housing | 28 9V Battery | 55 Bolt O-Ring |
| 02 Valve Plug | 29 Frame | 56 Clamping Feed Tube |
| 03 Valve Spring | 30 Trigger | 57 Clamping Feed Screw (Short) |
| 04 Exhaust Valve Assembly | 31 Printed Circuit Board | 58 Body |
| 05 Rammer Cap | 32 Bearing Carrier | 59 1/4" Elbow |
| 06 Rammer Cap O-Ring | 33 Trigger Adjuster Screw | 60 1/4" Hose |
| 07 Rammer | 34 Trigger Pin Retaining Screw | 61 OOPS Body |
| 08 Front Rammer O-Ring | 35 Push Button Strip | 62 OOPS Pin |
| 09 Rammer Bumper O-Ring | 36 Micro-switch | 63 OOPS On/Off Knob |
| 10 Rear Rammer O-Ring | 37 Circuit Board Retainer | 64 OOPS Insert |
| 11 Solenoid | 38 9V Battery Connector | 65 OOPS Screw |
| 12 Manifold | 39 Navigation Console | 66 OOPS Insert External O-Ring |
| 13 Barb | 40 Frame Screw | 67 OOPS Insert Internal O-Ring |
| 14 Solenoid Retaining Screw | 41 Trigger Pin | 68 Inline Regulator Swivel O-Rings |
| 15 Low Pressure Hose | 42 Inline Regulator Swivel | 69 Valve Guide O-Rings |
| 16 Torpedo | 43 Inline Regulator Top | 70 Bolt Plunger |
| 17 LPR Cap | 44 Inline Regulator Top O-Ring | 71 Bolt Spring |
| 18 LPR Adjuster Screw | 45 Inline Regulator Bottom | 72 Zick 2 Rammer Cushion |
| 19 LPR Adjuster Screw O-Ring | 46 Inline Regulator Bottom O-Ring | 73 Clamping Feed Screw (Long) |
| 20 LPR Adjuster Spring | 47 Inline Regulator Piston | |
| 21 LPR Piston | 48 Inline Regulator Piston O-Ring | |
| 22 LPR Piston O-Ring | 49 Inline Regulator Spring | |
| 23 LPR Piston Spring | 50 Inline Regulator Adjuster Screw | |
| 24 LPR Body | 51 Inline Regulator Adjuster O-Ring | |
| 25 LPR Body External O-Ring | 52 Detent | |
| 26 LPR Body Internal O-Ring | 53 Bolt | |
| 27 FRM Screw | 54 Bolt Pin | |

QUICK GUIDE

CONTENTS

QUICK SET-UP

ORIENTATION

USING YOUR ETEK3

ADVANCED SET-UP

EMORTAL BOARD

MAINTENANCE

UPGRADING

FAULT FINDING















SERVICE CENTERS





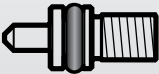





PARTS LIST

SPARES & ACCESSORIES

INDEX

PARTS LIST

SCREW	QTY	DESCRIPTION
	3	SOLENOID MANIFOLD SCREWS (M2.5 x6 CAP HEAD SOCKET)
	2	SOLENOID SCREW (2) (M1.6x16 Phillips Button Head)
	8	RUBBER GRIP SCREW (6), BBSS COVERS SCREW (2) (6-32UNC x5/16 COUNTERSUNK SOCKET)
	1	SHORT FEED NECK SCREW (10-32UNF x1/2 CAP HEAD SOCKET)
	1	LONG FEED NECK SCREW (10-32 UNF x5/8 CAP HEAD SOCKET)
	1	INLINE REGULATOR ADJUSTER SCREW (CUSTOM MANUFACTURED)
	3	TRIGGER ADJUSTMENT SCREW (6-32 UNC x3/16 SOCKET SET SCREW)
	1	TRIGGER PIN RETAINING SCREW (6-32 UNC x1/8 SOCKET SET SCREW)
	2	OOPS SCREW (10-32 UNF x1/2 SOCKET SET SCREW)
	1	VALVE PLUG (CUSTOM MANUFACTURED)
	1	LPR ADJUSTER SCREW (CUSTOM MANUFACTURED)
	2	FRAME SCREW (10-32 UNF x3/8 SOCKET BUTTON HEAD)
	1	FRM RETAINING SCREW (CUSTOM MANUFACTURED)
	2	MICRO SWITCH RETAINING SCREW (M2x10 Phillips Button Head)

O-RING	LOCATION	O-RING	LOCATION
 016	Inline Regulator Swivel Barrel Back LPR Body*	 013	LPR Piston
		 011	Back of the Rammer Rammer Cap Inline Regulator Bottom
 015	Inline Regulator Piston Inline Regulator Top (NBR 90) Barrel Front Bolt	 010	Inside LPR Body Inside Rammer Cap
		 009	Rammer Front Bumper Rammer Shaft
 14x2	LPR Body*	 008	OOPS Insert External Inline Regulator Adjuster Screw
		 007	Torpedo LPR Adjuster Screw
 014	Rammer Housing	 006	OOPS Insert Internal (NBR 90)

*** = EITHER 016 OR 14x2 O-RINGS CAN BE USED ON THE LPR BODY DUE TO THE FACT THAT IT HAS TWO SEALING O-RINGS.**

ALL O-RINGS ARE NBR 70 DUROMETER UNLESS OTHERWISE STATED.

QUICK GUIDE

CONTENTS

QUICK SET-UP

ORIENTATION

USING YOUR ETEK3

ADVANCED SET-UP

EMORTAL BOARD

MAINTENANCE

UPGRADING

FAULT FINDING

SERVICE CENTERS

PARTS LIST

SPARES & ACCESSORIES

INDEX

PARTS LIST

ECLIPSE GUN OIL

The recommended oil for use in all maintenance and servicing procedures that require oil.

**ECLIPSE GREASE**

The recommended grease for use in all maintenance and servicing procedures that require grease.

**TECH FLEX MAT**

Protect your Etek3 whilst you maintain it with the Eclipse Tech Flex Mat.

**Etek3 SPARES**

Replacement spares to service your Etek3 are available from all Eclipse Service Centres Etek3. (Not all parts shown).

**BALL DETENTS**

10 Replacement rubber Detents for your Etek3.

**ECLIPSE Etek3 TOOL TUBE**

This handy little tool tube includes all of the hex key sizes that you will need to strip and maintain your Etek3.



TECH SHIRT

The perfect pocket covered garment for carrying all those hex keys and spares for your Etek3.



09 F-TAC BACKPACK

The most advanced backpack we have ever made. It comes with a host of useful features and 3 large storage compartments.



09 LOWLAND KITBAG

What better place to keep your Etek3?



ECLIPSE ETEK3 LT UPGRADE KIT

Upgrade the Eket3 LT to an all metal spec Etek3 AM with this upgrade kit. Contains - metal frame assembly, metal feed neck assembly, metal eye covers.



ECLIPSE SHAFT 3 BARREL BACKS

Enhance your Etek3 barrel by upgrading to different size barrel backs for different size paint. Available in .685 .689 bore sizes. Colour and size subject to availability.



ECLIPSE ETEK3 EMORTAL BOARD

Upgrade circuit board for the Etek3 AM (and LT when upgraded to metal frame). Features a LCD interface with extensive fully adjustable parameters



QUICK GUIDE

CONTENTS
QUICK SET-UP
ORIENTATION
USING YOUR ETEK3
ADVANCED SET-UP
EMORTAL BOARD
MAINTENANCE
UPGRADING
FAULT FINDING
SERVICE CENTERS
PARTS LIST
SPARES & ACCESSORIES
INDEX

ACCESSORIES

Air System.....20
 Air Transfer Holes.....65
 Actual Rate of Fire.....36
 BACK.....37- 40
 Barb.....82 - 83
 Barb Clip.....17
 Ball Detection Time.....31
 Battery.....10, 13, 73, 76 – 77, 82 - 83
 Battery Level Indicator.....26, 33, 35
 Bearing Carrier.....63 – 64, 82 - 83
 Body.....13, 58 – 59, 63, 65, 67 – 68, 82 - 83
 Bolt.....13, 19, 78, 82 - 83
 Bolt Pin.....13, 58, 60, 82 - 83
 Bolt Plunger..... 82 - 83
 Bolt Spring..... 82 - 83
 Break Beam Sensor System (BBSS).....6-9, 26, 34, 52, 61- 62, 65, 78 - 79
 Break Beam Sensor System Indicator.....33-34
 CANCEL.....37 - 40
 Circuit Board.....13, 61, 65, 73, 82 - 83
 Circuit Board Retainers.....73, 75 – 76, 82 - 83
 DBOUNCE.....39, 50
 DEBOUNCE31
 Detent.....53, 79, 82 - 83
 DISPLAY.....37, 42
 Display Option.....33
 DWELL.....31, 39, 48, 78
 Eclipse Grease.....56 – 57, 59, 66, 70 - 71
 Eclipse Gun Oil.....59, 60, 68 - 69
 Emortal Board.....7, 12, 32-51, 75 - 76
 EMPTY.....39, 50
 Etek3 2-piece barrel.....14
 Etek3 AM.....12
 Etek3 LT.....11
 Etek3 Solenoid Assembly.....17
 Exhaust Valve.....13, 67 – 69, 77, 82 - 83
 EXIT.....37
 Eye Cover.....13, 74
 Eye Cover Screw.....13
 Feed Lever..... 13
 Feedneck.....13, 72, 82 - 83
 FILTER.....50

Filter.....17
 Fire mode.....28, 30
 Frame.....6, 63, 73, 82 - 83
 Frame Assembly.....13
 Frame Screw.....61
 Front Regulator Mount (FRM).....54, 67
 Frame Screw.....13, 82 - 84
 Front Stop Trigger Screw.....23
 FRM Screw.....13, 69, 82 - 84
 FSD COMP.....39, 48
 FSD DLY.....39, 48
 FULL.....40, 50
 GAME.....37, 42
 Game Timer..... 35
 GRN.....11
 Inlet Barb.....17.
 Inline Regulator Adjuster Screw.....15, 55, 82 - 84
 Inline Regulator Assembly.....13, 15, 54 – 55, 61, 79
 Inline Regulator Bottom.....15, 54, 82 - 83
 Inline Regulator Piston.....15, 54 – 55, 82 - 83
 Inline Regulator Spring.....15, 54-55, 82 - 83
 Inline Regulator Swivel.....15, 82 - 83
 Inline Regulator Top.....15, 54 – 55, 82 - 83
 KICK-IN.....39, 48
 LED Circuit Board.....6
 LOAD.....38, 44
 Loader.....22
 LOCK.....38, 44
 Lock Indicator.....33, 35
 Low Pressure Regulator (LPR) Assembly.....16, 24, 56- 57, 67
 LIGHT.....39, 48
 LINEAR.....47
 LP Hose.....17, 82 - 83
 LPR Adjuster Screw.....16, 82 - 84
 LPR Adjuster Spring.....16, 56 -57
 LPR Body.....13, 16, 56 -57, 67, 69, 79, 82 - 83
 LPR Body Vent Hole.....79
 LPR Cap.....13, 16, 56 – 57, 82 - 83
 LPR Piston.....16, 56 -57, 82 - 83
 LPR Piston Spring.....16, 56 – 57, 82 - 83
 Macroline Elbow.....13, 21
 Macroline Hose.....13, 21
 Magnet Return Strength Screw.....23
 Main Menu.....37, 42
 Manifold/Body Gasket.....17, 77

Manifold/Solenoid Gasket.....17, 77
 Manifold Retaining Screws.....17, 84
 MAX ROF.....38, 46
 Maximum ROF.....28, 30
 Menu System.....36, 41
 Menu Tree.....37 - 40
 Micro-switch.....34, 62 - 64, 73, 78, 82 - 83
 Micro-switch retaining screw.....84
 MODE.....38, 45
 Navigation Console.....8, 18, 32, 75 - 76, 82 - 83
 OFF?.....37
 OFF ROF.....38, 47
 On/Off Purge System (OOPS).....70 - 71, 73
 OOPS Body.....13, 70 - 71, 82 - 83
 OOPS Insert.....13, 70 - 71, 82 - 83
 OOPS Knob.....13, 70 - 71, 82 - 83
 OOPS Pin.....13, 70 - 71
 OOPS Screw.....13, 82 - 84
 Operational Overview.....19
 Parameters.....27, 28, 41
 Peak Rate of Fire.....36
 Plastic Pushbutton Strip.....75, 82 - 83
 PRESET.....38, 44
 PSP Divisional.....30
 PSP Pro.....30
 PULL NO.....39, 48
 PULL TM.....40, 50
 Rammer.....13, 19, 58 - 59, 67, 77, 82 - 83
 Rammer Cap.....13, 58 - 59, 68, 82 - 83
 Rammer Cushion.....82 - 83
 Rammer Housing.....13, 68, 82 - 83
 Ramp Kick In.....29-30
 Ramp Restart Time.....29-30
 RAMP SET.....39, 47
 RATE.....39, 48
 Rear Stop Trigger Screw.....23
 REL TM.....40, 50
 Reset.....31
 RESTART.....39, 48
 ROF CAP.....38, 46
 Rubber Gasket.....65
 Rubber Grip.....61-62
 Rubber Grip Screw.....62, 75, 82 - 84
 Run Screen.....33
 SAVE.....38, 45

Select Button.....18
 Service Centres.....80-81
 Set Up Menu.....38-40, 43
 Set Up Mode.....27
 Set Up Parameters Table.....30
 Shot Counter.....35
 SLEEP.....39, 48
 Solenoid Assembly.....13, 17, 65 - 67, 77, 82 - 83
 Solenoid Body.....17
 Solenoid Clip.....17, 65 - 66
 Solenoid Manifold.....65 - 66, 82 - 83
 Solenoid Manifold Assembly.....13
 Solenoid Pilot Section.....17
 Solenoid Retaining Screw.....17, 65, 82 - 84
 Solenoid Wires.....61 - 62
 Spool Shaft.....17, 66
 START.....37, 42
 STEP.....47
 SUSTAIN.....39, 48
 TIMER.....37, 42
 TIMING.....39, 48
 Torpedo.....13, 82 - 83
 Tournament Lock.....25
 TRAININ.....40, 51
 Trigger.....13, 23, 64, 79, 82 - 83
 Trigger Adjustment Screw.....23, 82 - 84
 Trigger Assembly.....63 - 64
 Trigger Detection Indicator (TDI).....33-34
 Trigger Pin.....63 - 64, 82 - 83
 Trigger Pin Retaining Screw.....63-64, 82 - 84
 Trigger Retaining Clip.....13, 64, 73
 T-Slot Mounting System.....21
 T-Slot Rail.....73
 TYPE.....39, 47
 USER1.....38, 44
 USER2.....38, 44
 User Interface.....33
 Valve Assembly.....67
 Valve Plug.....13, 67, 82 - 84
 Valve Spring.....67, 69, 82 - 83
 Velocity.....24

QUICK GUIDE

CONTENTS
 QUICK SET-UP
 ORIENTATION
 USING YOUR ETEK3
 ADVANCED SET-UP
 EMORTAL BOARD
 MAINTENANCE
 UPGRADING
 FAULT FINDING
 SERVICE CENTERS
 PARTS LIST
 SPARES & ACCESSORIES

INDEX

INDEX





GET MORE AT **PLANETECLIPSE.COM**

Units 5-8 Southfield Ind Est, Praed Road Trafford Park, Manchester, England, M171SJ
Call UK & Europe: +44 (0)161 872 5572 Call USA & Canada: 401 247 9061

PRINTED IN CHINA
ET3M09VOL2

Licensed under one or more of the following patents:
US 6311682, 6615814, 5881707, 5967133, 6035843, 6474326B1, 6637421B2 UK GB 234270, GB 2345953
© 2009 Copyright Planet Eclipse Ltd. Eclipse, the Estar Logo Device, Ego, Etek, Emortal and Geo are all either design trademarks, registered trademarks or trademarks of Planet Eclipse Ltd.