

SHOCKER[®]

OPERATION AND MAINTENANCE MANUAL

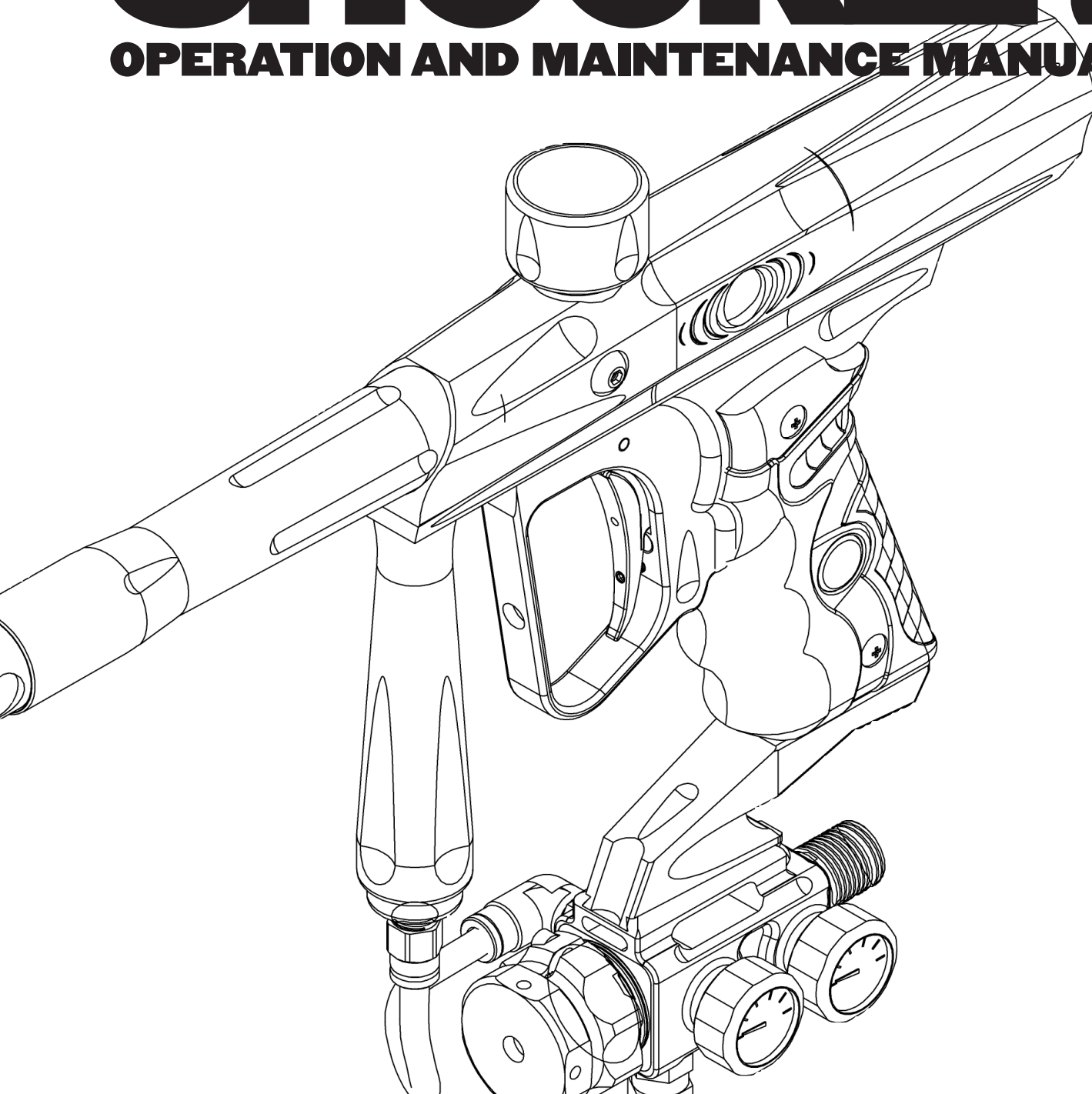

SMART  PARTS[™]



PLEASE READ ALL OPERATING INSTRUCTIONS BEFORE USING THE SHOCKER[®] PAINTBALL MARKER

WARNING

This is not a toy. Misuse may cause serious injury or death. Eye protection designed specifically for paintball must be worn by user and persons within range. Recommend 18 years or older to purchase. Persons under 18 must have adult supervision. **READ OWNER'S MANUAL BEFORE USING.**

SHOCKER QUICK START

- 1.** Thread barrel onto Shocker. Put barrel cover over barrel, securing barrel cover cord over marker body.
- 2.** Air up tank with Max-Flo on/off in OFF position
 - A.** If using CO² or preset Nitrogen, thread on tank to air adapter.
NOTE: It is very important when using a CO² or preset Nitrogen tank that an on/off valve is used. An anti-siphon tube is also needed for CO². Smart Parts makes a variety of on/off valves to adapt to any tank in any setup configuration.
- 3.** Insert loader into feedport. A HALO or Evlution II is recommended for their feed rates. A non agitating loader will not work properly.
- 4.** Gas up the Shocker by turning the on/off valve to the on position slowly.
- 5.** Turn the Shocker on by holding in the clear button on the back of the grip frame in for approximately two seconds. The Shocker will chirp and start to blink blue in a double tap sequence. Push the button once more to put the Shocker in vision mode, if so equipped. The blue light will now blink rapidly and continuously. Shutting the Shocker off also acts as a safety and is accomplished by holding the button in for two more seconds until the light shuts off and the Shocker chirps down.
- 6.** Pour paint into the loader and chronograph the Shocker.
- 7.** Win the tournament.

OVERVIEW

Welcome to the 2003 Shocker. Smart Parts has made the Shocker considerably lighter and drastically smaller. The Shocker is an open bolt, seal forward marker. Seal Forward Technology (SFT) is unique to the 2003 Shocker. SFT allows the Shocker to be an open bolt marker, while still having the breech seal a split second before the ball is fired, like a closed bolt. By sealing the breech before the ball is fired, the Shocker is able to have accuracy and trajectory like a traditional closed bolt, but also the rates of fire and simplicity of an open bolt. The rate of fire and air efficiency have been improved to let you play longer, and with more intensity. Smart Parts has done all this for one reason: you, the player. We wanted a marker that stood head and shoulders above the rest so that using the Shocker would not only make a player able to compete, but able to dominate. We hope that you enjoy using your Shocker as much as we enjoyed creating it.

STATISTICS

Length/Height/Weight:	8 inches (without barrel) x 6 inches, 1 lbs. 14 oz.
Operating Pressure:	180-220 psi
Power Source:	Common 9 volt battery
Propellant:	CO ² or Nitrogen/Compressed Air
Rate of Fire:	20+ balls per second, 1200+ balls per minute
Mode of Fire:	Semi automatic, tournament legal mode only
Vision Ready:	Yes
Barrel Thread:	Original Shocker
Lubricant:	Use only "Shocker Grease"

MAINTENANCE

The 2003 Shocker has been designed with simplicity in mind so that you, the player, can maintain the marker with little effort. This being said DOES NOT MEAN you should neglect your Shocker. For best performance, clean and grease your Shocker frequently. Many players clean their Shockers after every use. While this may seem a bit extreme, being vigilant in the upkeep of your Shocker will extend its useful life considerably. NEVER immerse your Shocker in water. If your Shocker should become wet, remove barrel and rubber grips and allow to air out, then follow disassembly instructions for full cleaning. Clean with a damp cloth and alcohol, grease ONLY with Dow 33 Shocker grease. Use high quality paintballs.

As far as special circumstances considering the maintenance of the Shocker, it is recommended that you replace both the 17/90 o-ring inside the rear end and the 17/70 o-ring inside the front end of the fire chamber every 8,000 to 10,000 paintballs. This will prevent the Shocker from leaking down the barrel. The regular changing of these two o-rings will also keep the Shocker consistent and provide for better efficiency.

TOOLS YOU WILL NEED:

3/16" Allen wrench	Dow 33 Shocker Grease
1/8" Allen wrench	Phillips screwdriver
5/64" Allen wrench	Small precision Phillips screwdriver
1/16" Allen wrench	Needle nose pliers
.050" Allen wrench	1/8" socket
Wooden kitchen spoon or one foot section of 3/8" dowel rod	

BORE SIZING

Bore sizing for the 2003 Shocker should be handled much like the Shocker 4x4 or any other closed bolt marker. The ideal bore fit is when a ball is inserted at the bore (the end that the threads are on) and it does not slip into the barrel or roll through. The ball should stay at the end of the barrel. The ball should then be able to be expelled by blowing it through the barrel with a minimum amount of force. If you are unable to blow it through the barrel with very little effort or the ball gets stuck, increase the bore size of your barrel. If paint rolls through the barrel or drops off badly when firing, decrease the bore size of your barrel.

VISION INSTRUCTIONS

Using the 2003 Shocker with Vision is relatively simple. Turn on the Shocker as you normally would by holding the button on the rear of the grip frame down for approximately two seconds until it turns on and chirps. The blue light in the button should be blinking in a two flashes, then a pause, pattern. To enter the Shocker into Vision mode, simply push the button once more (it will chirp). The blue light should be blinking rapidly and continually. You are now in Vision. To exit Vision mode, simply tap the button once more to put the Shocker back to standard mode. This is helpful for clearing the marker out or degassing. With Vision on, the eye will prevent the Shocker from firing if it senses that there is no paintball loaded.

DWELL+RATE of FIRE ADJUSTMENT

The dwell and rate of fire adjustments are made using the same two buttons. Removing the two grip screws on the left (non-vision ready) side of the Shocker and exposing the circuit board provides access to the adjustment buttons. They are flat, gray, and located towards the front of the board, one just above the round black speaker, the other just below the wiring harness plug.

DWELL Dwell is essentially how much air is being passed through the solenoid to fire the marker. Increasing dwell will increase velocity, decreasing will decrease velocity. It is important to balance the dwell and operating pressure as too high a dwell and too low an operating pressure will cause poor efficiency. Too high an operating pressure and too low a dwell will cause ball breakage. Dwell is adjusted in .25 millisecond increments from 3 ms to 14ms. To adjust, turn the Shocker on, and then simply press the upper dwell button once for every .25 ms you would like to increase. The board will chirp for every adjustment. To lower the dwell press the lower dwell button once for every .25 ms dwell reduction. Maxing out or bottoming out the dwell will result in the board chirping in a rapid lower tone. Increase or decrease dwell to avoid this. The average setting currently for the Shocker is twenty chirps from the absolute bottom (8ms) with an operating pressure at @190psi.

RATE of FIRE The rate of fire adjustment uses the same two buttons as the dwell does. The rate of fire is actually the setting of the recharge between shots. The less time the recharge setting is between shots, the higher the rate of fire. To adjust the rate of fire, turn the Shocker on. Pull and hold in the trigger. The recharge time is adjustable from 30 ms to 70ms, in 1ms intervals. To increase the recharge time of the Shocker, which will slow your rate of fire, press the upper dwell button once for every 1 ms increase. The board will chirp for every adjustment. To decrease the recharge time of the Shocker, press the lower dwell button once for every 1 ms of decrease. This will increase your rate of fire. It is important that you pull and hold the trigger in when adjusting the rate of fire. Not holding the trigger in will result in an adjustment of your dwell setting, not your rate of fire.

TRIGGER ADJUSTMENT

The Shocker has four main points of trigger adjustment, providing you, the end user, with the perfect trigger setup. Adjustments in the pre-travel, post-travel, magnetic tension, and switch activation are possible with a wide range of adjustment for each.

PRE-TRAVEL Pre-travel determines how far you have to pull the trigger back until it reaches the fire point of the switch. The pre-travel screw is located vertically at the front of the trigger, just behind the forward grip frame screw. To adjust your pre-travel, use your .050" Allen wrench and turn in (clockwise) to reduce the travel distance before the switch activates. Turn out (counter-clockwise) to increase the travel distance. *Turning the pre-travel screw too far in can and will cause the trigger not to activate.* If you have adjusted your pre-travel and the Shocker will not fire; begin to turn the screw out until the Shocker will fire.

POST-TRAVEL Post-travel determines how far the trigger cycles past the fire point of the switch. The post-travel screw is located horizontally, at the bottom of the trigger. It should have several threads showing from the back side of the trigger. To adjust post-travel, use your .050" Allen wrench and turn in (clockwise) to reduce the distance your trigger travels after the Shocker activates the switch and fires. Turn the screw out (counter-clockwise) to increase the distance your trigger travels after the Shocker activates the switch and fires. *Turning the post-travel screw too far in can and will cause the trigger not to activate.* If you have adjusted your post-travel and the Shocker will not fire; begin to turn the screw out until the Shocker will fire.

TRIGGER ACTIVATION POINT The trigger activation point adjustment is similar to the pre-travel, but directly affects when the trigger switch is activated within the entire trigger cycle. The trigger activation point screw is located horizontally halfway up the trigger. To adjust the trigger activation point, use your .050" Allen wrench and turn in (clockwise) to make the trigger activate sooner in the trigger pull or turn the screw out (counter-clockwise) to activate later in the trigger pull. *Turning the trigger activation point screw too far in OR too far out can and will cause the trigger not to activate. Turning the trigger activation point screw in too far may cause SEVERE TRIGGER SWITCH DAMAGE.*

MAGNETIC RESISTANCE THIS ADJUSTMENT IS NOT EASY. IF YOU READ THESE INSTRUCTIONS AND ARE UNSURE OF YOUR ABILITY TO MAKE THIS ADJUSTMENT PROPERLY, CALL SMART PARTS OR YOUR LOCAL PRO SHOP FOR HELP. Setting the magnetic resistance of the Shocker is a lot like changing or adjusting trigger springs in other markers. The Shocker has no springs, so the tension of the trigger is adjusted by how far apart the two magnets in the trigger are. The magnetic resistance adjustment is located behind the circuit board in the grip frame. To make any adjustments you must first take off the rubber grips by removing the four grip screws with a Phillips screwdriver. Then remove the battery by grasping the battery by the connector, NOT THE WIRES. Pull the connector from the battery terminals and remove the battery. Next, gently remove the wiring harness plug from the circuit board (this is the opposite end of the same wiring harness you worked with in the assembly/disassembly section). Now gently tap out the two roll pins located in front of the grip and behind the trigger, angled slightly from each other. DO NOT force the pins. Once out, gently remove the circuit board. Looking from the back of the grip frame forward, you should see a threaded hole below the location of the roll pins you just removed. Using your 1/8" Allen wrench, turn the magnet in (clockwise) to increase magnetic tension and out (counter-clockwise) to decrease magnetic tension. Once set, replace the circuit board by inserting the trigger switch end up and into the grip frame with the switch facing the trigger. Be sure to slide the bottom end of the board into its C shaped groove at the bottom. Gently tap the roll pins back in, making sure that the pins go smoothly through the round holes in the trigger switch. Reattach the wiring harness plug. Insert the 9 volt battery in the frame so that it rests without compressing the board or extending past the sides of the grip frame. Reconnect the 9 volt battery and lay wires so that the grips will not crush them. Put grips back on and reattach four grip screws.

DISASSEMBLY / ASSEMBLY

- 1.** DEGAS THE SHOCKER AND MAKE SURE NO PAINT IS IN THE MARKER.
- 2.** Remove barrel
- 3.** Using a 3/16" Allen Wrench, unscrew and remove the Bolt guide (end cap)
- 4.** Take the bolt guide and insert it tapered end first into the front of the marker, centering the tapered nose of the bolt guide on the center spindle of the bolt. Gently push the bolt guide into the body until the bolt and bolt sleeve appear at the rear of the body. Set aside bolt guide and gently pull the bolt and bolt sleeve from the Shocker.
- 5.** Remove bolt from bolt sleeve by pulling the bolt from the front of the bolt sleeve. Set aside both parts.
- 6.** Using the handle end of a wooden kitchen spoon or a piece of 3/8" dowel rod, remove the fire chamber. Insert the dowel rod from the front of the marker, angling it slightly towards the wall of the marker body so that it rests on the visible rear section of the fire chamber. Push gently, but firmly on fire chamber until it emerges from the rear of the body. Set aside dowel rod or spoon and pull fire chamber out. Set aside.

This covers basic repair and maintenance disassembly. The following steps include finishing disassembly for a full takedown of the Shocker, including solenoid maintenance.

- 7.** Remove the wiring harness by getting as close to the lower (grip frame) circuit board as possible and gently removing the wiring harness plug in a careful side to side motion until the harness plug comes free. DO NOT remove the wires from the wiring harness plug.
- 8.** Using the 1/8" Allen wrench, unscrew and remove the two grip frame screws. CAREFULLY separate the grip frame from the body, paying careful attention to the wiring harness attached to the circuit board at the midway point of the grip frame. Pull wiring through grip frame gently and set aside grip frame assembly.
- 9.** For solenoid disassembly, first unscrew the two cap screws holding the circuit board to the solenoid with a 5/64" Allen wrench. Then, using the small precision Phillips head screwdriver, remove the two long solenoid body screws (the end opposite the two cap screws that were just removed) and slowly pull the solenoid apart and away from the body. The silver spool end of the solenoid should be all that remains attached to the body.
- 10.** To remove the spool section, use the 1/8" socket and carefully loosen and remove the brass solenoid mount screws. Then use the precision Phillips screwdriver to remove the black end cap and spring. Use needle nose pliers to pull the spool from the spool housing. Clean and inspect the spool for debris or damage. Grease spool moderately with Shocker grease only, the reinstall by placing flat end in first, with the pointed end facing outward towards the cap and spring. Place spring, small end first, over the small point at the end of the spool. Reinstall cap with line side of cap facing the body of the Shocker. *Not facing the line towards the body of the Shocker will cause the solenoid to leak.* DO NOT OVERTIGHTEN SCREWS. Inspect center pilot section of the solenoid for debris and to be certain that the white manual override button is still in place. If the override button is missing, immediately call Smart Parts or your local pro shop for a replacement. Then inspect the plunger and plunger spring at the far end for dirt and debris.

This completes the disassembly process. The following steps detail the cleaning, lubricating, and reassembly of the Shocker.

- 11.** Replace spool section of the solenoid back on the Shocker body with the black cap facing the front of the Shocker. Install solenoid mount screw and tighten down until firm. DO NOT OVERTIGHTEN SCREWS.
- 12.** Insert the solenoid plunger back into the coil, spring side last so that the end with the black center faces out. Place pilot so that the manual override button (black center) side is facing the plunger/coil section and the other (white center) side will be facing the spool section The manual override button should face the circuit board.

CONT'D

- 13.** Push the long solenoid body screws through the plunger/coil section and pilot of the solenoid until they stop, then begin screwing them into the spool section. Tighten all three sections together, making sure the pieces line up properly. **DO NOT OVERTIGHTEN SCREWS.**
- 14.** Remove the left (non-vision eye) side grip panel by removing the two grip screws with a Phillips screwdriver. To reconnect the grip frame, bring the body and grip frame close together, very gently inserting the wiring harness directly through the opening in the top of the grip frame, just above the battery. Now bring the grip frame and body all the way together, being extra cautious that none of the black wires get wedged between the clear on/off button in the grip frame and the on/off switch located on the back end of the upper circuit board (the on/off switch is gray and flat). *Getting wires caught between the on/off switch and on/off button may cause severe damage to the wires and the on/off switch.* Thread in the two grip frame screws and tighten with 1/8" Allen wrench. Now reconnect the wiring harness into the lower board. Looking carefully at the wiring harness, there is a line on the side of the wiring harness plug. This line should face closest to the battery while plugging it in. Push the harness plug in firmly until it stops. Use your thumbnail to make sure the plug is all the way in by pushing on the edges of the plug to make certain of full contact.
- 15.** Clean the fire chamber and inspect the o-rings for damage. Pay special attention to the two internal o-rings in the fire chamber. Make sure they are clean and undamaged. Also, be sure to clean the inside of the fire chamber to prevent dirt and grease buildup. Wiping both the external and internal surfaces with a paper towel or soft rag is ideal. Grease the outer three and inner two o-rings liberally. Set aside. Clean and inspect the bolt and bolt sleeve, checking for o-ring damage. Wipe down both internally and externally before greasing liberally and reassembling. Reassemble by setting the bolt sleeve on a flat surface, flared end facing down. Apply grease liberally to external bolt o-ring and the inch or so behind it. Apply grease to internal bolt sleeve seal, midway down the internal diameter of the bolt sleeve. Insert bolt into bolt sleeve with the four hole bolt face pointing up, and the flared end of the bolt sleeve facing down. Grease the four external bolt sleeve o-rings liberally. Lay the bolt guide on a flat surface, so the guide tip points up. Grease all three o-rings on the bolt guide; more so on the two small shaft o-rings than the larger cap o-ring. Install the bolt and bolt sleeve on the bolt guide by sliding both combined pieces over the bolt guide. The bolt and bolt sleeve should rest at the bottom of the bolt guide, directly touching the end cap section. Make sure that the flared end of the bolt sleeve is closest to the end cap section of the bolt guide. Slide the fire chamber over the exposed front of the bolt. Be sure that the end with the two o-rings slides over the bolt last, so that it will go in the Shocker body first, closest to the barrel.
- 16.** Reinstall the whole assembly in the Shocker by gently, but firmly pushing it into the body. Keep pushing in by hand until the fire chamber stops against the front of the body. Also make sure that the assembly goes in smoothly and that none of the external o-rings are displaced or cut as they pass the cut out Shocker logo in the body. Do not force the parts to go in, as this may cut o-rings. Instead, wiggle the parts slightly back and forth while applying light forward pressure to make the o-rings seat properly. At this point only the threads on the bolt guide should be showing outside the Shocker body. Lightly tap the bolt guide from the rear with the palm of your hand, then screw bolt guide back in with your 3/16" Allen wrench. Your Shocker is now ready to use.

TROUBLESHOOTING

SHOCKER IS DIFFICULT TO SWITCH ON/OFF.

- Solenoid wiring harness is in the way of the on/off button and on/off switch. Remove the grip frame. Relocate wires away from switch and check for damage. Reassemble properly.
- The battery is low or dead. Inspect and replace.

BREAKING PAINT.

- Paint to barrel match is wrong. The paint you are using is too large for the barrel you are shooting it through. Get a Freak System or find a paintball that fits your barrel properly.
- Ball Detents are damaged or missing. Check to make sure white delrin ball is intact and reactive on both sides. Replace if damaged or missing.
- Paint is too low quality or too brittle. Switch to a name brand, high quality manufacturer.
- Turn on Vision eye (if so equipped).
- Check Shocker battery. It may be low, causing incomplete cycling.
- Loader may not be keeping up. Check loader batteries or use a faster loader. Halo or Evlution II is recommended.

AIR LEAKS DOWN THE BARREL WHEN GASSING UP THE SHOCKER.

- Cover 3/16" Allen wrench hole on back of Shocker (in the middle of the Crosshair logo) with a rag. This should force the marker to seal up. When gassed up, little or no air seems to be getting to the Shocker.
- The 17/90 and 17/70 o-rings on the internal surface of the fire chamber are worn. Replace and lubricate thoroughly. The 17/70 or "soft" o-ring goes to the front of the fire chamber while the 17/90, or "hard" o-ring goes to the rear.

WHEN GASSED UP, LITTLE OR NO AIR SEEMS TO BE GETTING TO THE SHOCKER.

- Degas, then remove internals. Check for o-ring binding, grease with Dow 33, then reinstall.
- The bolt sleeve is in backwards. Remove and replace with the flared end facing towards the rear of the Shocker.
- The fire chamber is in backwards. Remove and replace with the dual o-ring end facing towards the front of the Shocker.
- Pilot on solenoid may be clogged. Clean or replace pilot.
- Bolt may be jammed, check for paint shell or debris.

AIR IS LEAKING INSIDE THE SHOCKER.

- Solenoid mount screws are loose. Tighten screws to stop the leak but DO NOT OVERTIGHTEN.
- Solenoid body screws are loose. Tighten screws to stop the leak but DO NOT OVERTIGHTEN.
- Solenoid o-ring, spool o-rings, or solenoid mount o-rings are damaged or dirty. Clean or replace o-rings or replace spool.
- Solenoid spool end cap is upside down. Turn over so line is facing Shocker body.

VELOCITY IS INCONSISTENT

- Clean regulator and inspect seat assembly. (See separate Max-Flo manual)
- Check paint to barrel match. Paint may be too large or too small for the barrel you are shooting it through. Consider a Freak Barrel System or find a paintball that fits your barrel properly.
- Check the Shocker and Max-Flo regulator for leaks.

THE SHOCKER HAS LOW VELOCITY.

- Your battery is low. Replace with fresh name brand battery.
- Turn the on/off valve on all the way.
- Check your operating pressure so that it is at @190psi. Increase to 190psi if lower.
- If pressure is at @190psi, slowly increase dwell setting.

CONT'D

THE SHOCKER IS DROPPING OFF.

- Clean and grease the Shocker.
- Increase the dwell slightly.
- Use Vision eye.

THE SHOCKER IS GASED UP, BUT WILL NOT SHOOT.

- Turn battery on.
- Battery may be dead. Replace with fresh name brand battery.
- Check to see if solenoid wiring harness has come free from either end of the circuit board. Reconnect.
- Vision eye is on but no paint is loaded. Add paintballs or turn Vision off.

THE VISION EYE IS NOT WORKING/THE SHOCKER WILL NOT FIRE IN VISION.

- While in Vision mode, check to see if the blue light at the rear of the grip frame is blinking in a slow, single flash mode. If so, there is a jam. The jam may be caused by an odd shaped or badly discolored ball. Take the Shocker out of Vision mode; clear the jam, then put the Shocker back into Vision mode to reset.
- Make sure your agitating hopper is on and feeding properly. A break in feeding from your hopper will cause the Vision to keep the marker from firing to prevent ball breakage. Turn on, speed up, or replace your hopper. Don't forget to check you hopper batteries.
- If the Shocker fires, but Vision will not work, check to see if you have previously broken a ball. Broken paint may cover the actual Vision eye and cause it to misread. Clean it with a paper towel and a small amount of alcohol. If this does not work, the eye may be damaged and will need to be replaced. Call Smart Parts or your local Smart Parts dealer for parts.
- The Vision may not read certain dark shell paints, such as black. While it is not a given that the Vision does not see black shell paint, continued failure of the Vision system with black shell paints should indicate for you to try a bit of a brighter shell paintball.

WARRANTY

Smart Parts warrants for one (1) year to initial retail purchaser that the paintball marker and regulator are free from defects in materials and workmanship. Disposable parts (batteries, o-rings, seals, etc.) are not warranted. The valve assembly is warranted for six (6) months. The solenoid and electronics on the marker are unconditionally warranted for six (6) months, plus an additional warranty of six months for electronic parts only (installation and labor are not included.) This warranty does not cover surface damages (scratches and nicks), misuse, improper disassembly and re-assembly, attempts made to drill holes or remove metal from the external surfaces which could degrade performance and reduce pressure safety factors of the marker. Do not make changes to the basic marker parts without written approval. The only authorized lubricant for the marker is DOW 33 Lubricant. Use of any other lubricant could result in voiding your warranty. Paintball markers are non-refundable. This warranty is limited to repair or replacement of defective parts with the customer to pay shipping costs. This warranty is effective only if the customer returns the warranty registration card enclosed with the marker. The warranty is non-transferrable. Do not attempt to alter the trigger assembly in any way, as this will void your Smart Parts Inc. warranty. Trigger alteration of any kind may result in serious injury.

TECH SUPPORT

Our Technical Support Department is open Monday through Friday, from 10am to 6pm EST, and can be reached at 724-539-2660. Additional support is available through our web site, smartparts.com.

