

# WARP FEED Instruction Manual



# WARP FEED®

## INSTRUCTIONS

### Overview

The patent pending Warp Feed® is the world's first universal force-feed system. It is a "friction drive," meaning the drive wheel has friction discs instead of pockets so the balls can never jam or break. When you stop shooting, the feed wheel will harmlessly slip past the balls in the system and then pause, waiting for the next shot. When a "fire" signal comes from the gun, or when the sensor determines the gun has been fired, the motor will spin the feed wheel and push balls into the feed tube. The feed wheel will continue to spin for a preset amount of time that is adjustable. The system uses special MOSFET technology that eliminates the need for an on/off switch. The battery only feeds power to the system when it receives a signal to feed balls. Disconnect your battery for very long storage.

### What you need to make it work

When using the Warp Feed the balls are being PUSHED into the breech. Because of this it becomes very important that you use the specially designed Parabolic PowerFeed Plug supplied with your unit if you are mounting it on a PowerFeed gun. The standard PowerFeed Plug will NOT work at all with the Warp Feed. It is just as important that the barrel you are using has a good ball detent system or nubbin. Test this yourself by pushing a ball past the detent; if it offers little or no resistance, the Warp Feed may double feed balls or, worse, cause the second ball in the tube to get chopped.

### Jumpers

There are two sets of jumpers on the circuit board, which can be found under the cover plate on the back of the unit. The first jumper has three positions labeled "-" (Negative), "+" (Positive), and "sens" (Sensor). If the gun sends a ground signal or you are interfacing to a switch mounted on the gun, select the "-" position. Select "+" if the gun on which you are installing the system sends a positive voltage pulse every time the gun is fired or if you have an external vibration sensor plugged into the input jack. The "sens" position activates the built in sensor that reacts to the gun's vibration when fired and requires no further interface. This setting works best on guns with blowback; there may be problems with guns that don't have enough vibration. Leave this jumper in place for guns using an external sensor; it protects your transistors from blowing up from high voltages that can be generated by hitting the external sensor. The second jumper has four positions and the unit comes with jumpers in a non-functional storage position on all four. These jumpers control the length of time the feed wheel spins after it gets the signal from the gun. The more jumpers you install the shorter time the wheel will spin. It does not matter which ones you install first because they all shorten the timing an equal amount. You should set the timing so that at your maximum firing rate the wheel spins continuously. Setting this to the minimum timing to get reliable feeding will maximize battery life. Store the jumpers you remove in a safe place in case you need them.

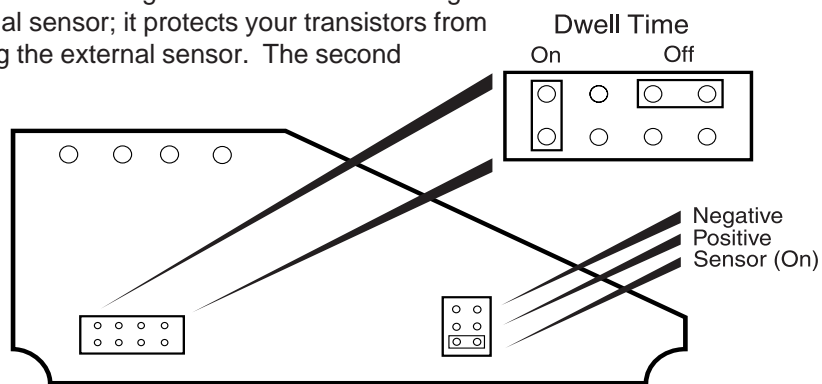

### Vibration Sensor

Some versions of the Warp Feed come with either an internal or externally mounted vibration sensor. This sensor allows you to use a variety of non-electronic guns with the Warp. It senses the vibration and rotates the feed wheel. We have included a sensitivity adjustment on the circuit board since all guns vibrate different amounts. This is a one-turn potentiometer that varies the offset voltage and makes the sensor more or less sensitive. To set the adjustment, unscrew the gear cover plate and find the blue potentiometer. To set the system to its highest sensitivity, turn the potentiometer clockwise until the motor spins, then back off until it stops. This should be your most sensitive adjustment, but will likely spin the motor when you don't want it to. Fire your gun and continue to rotate the potentiometer counterclockwise until the Warp starts missing shots. Your best position will be about half way between most sensitive and missing shots.

### Run In

The electric motor has carbon brushes that spark when new. The sparking creates electrical noise that looks like the sensor is sending a fire signal. The motor may run continuously when using the sensor system on a brand new Warp adjusted to maximum sensitivity. This will go away after a short run in period. The quickest way to break in your brushes is turn your sensitivity adjustment clockwise until the motor spins, then back it off a little. Let the motor spin as long as it wants and when the brushes break in it will stop on its own in several minutes. Do this several times and you should be ready to go.

### Maintenance

Your Warp Feed should require little maintenance, but you should do the following to keep it in top shape:

- 1) Lubricate the feed wheel, shaft, and gears with any good quality grease;
- 2) Replace the oring drive belt once or twice a year to maintain reliable operation;
- 3) Occasionally clean the inside of the case to prevent build up of grime that may interfere with the gearing.

## **Batteries**

The Warp Feed offers several options for battery power. The unit comes with a battery clip for four AA batteries, which delivers six volts. This should be sufficient to feed most standard guns and is the best battery value. Higher voltages will spin the feed wheel faster allowing for very fast firing rates. If the six-volt clip does not keep up with your gun, it can be replaced with a nine-volt alkaline battery, which keeps up with feed rates of well over 10 BPS. We suggest you hold a spare 9-volt battery in the compartment next to the one you are using; the spare will come in handy if you lose power on the field. There is an optional rechargeable battery pack that puts out 10 volts, see your dealer for availability. Never put more than 12 volts into the system! Doing so will blow the board. There is no on/off switch because the components are all voltage controlled and use very little current. The battery will drain about 4 volts per month so disconnect it for long term storage.

## **Feed Tube**

The Warp Feed comes supplied with a length of feed tube and two feed tube adapters. One adapter fits into the front port of the Warp Feed and the other fits on the bottom of the PowerFeed Tube. Use a razor to cut the feed tube slightly longer than needed and force it all the way into the adapters. Try mounting it on the gun; if it's too long trim the feed tube and try again. Make sure the feed tube is forced all the way inside the adapters for best performance. We have eliminated the elbow because it slows the ball feed down.

## **Hopper**

We only recommend an agitator loader such as the Viewloader® series of loaders. These are the only loaders capable of keeping up with today's high firing rates. The Warp Feed body must be mounted far enough out from the gun to clear the feed tube but can be modified to fit closer to the gun. To fit the loader in tight requires a high temperature heat gun; heat up a small section of the loader and your gun barrel to form a dent in the side of the loader to clear the Warp's feed tube. See [www.airgun.com](http://www.airgun.com) for detailed information on this process or see your qualified air smith.

## **Lefties**

For left handed shooters simply reverse the mounting plate and mount the Warp Feed on the other side of the gun.

## **Automag Bodies**

For best results use the specially designed Warp Feed body from Airgun Designs. See your dealer about purchasing a new body for your 'Mag. If you're a right handed player; the Hopper Right PowerFeed Body will work too. See your dealer about the Extended Parabolic PowerFeed Plug that will fit into the long end of the feed tube and allow the Warp Feed to push balls into the lower end of the feed tube. Vertical feed and hopper left bodies may work if you extend the feed hose, but we do not guarantee the performance. Contact Pro-Team Products at (904) 437-3375 for special adapters and mounts for a wide variety of guns.