



PLANET ECLIPSE: GTEK 160R

USER MANUAL / ENGLISH

**GTEK**  
160R

.68 CAL

**APT**  
ECLIPSE<sup>®</sup> ADVANCED  
PAINTBALL TECHNOLOGY

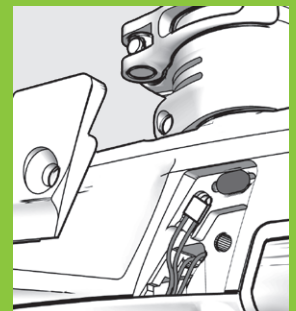
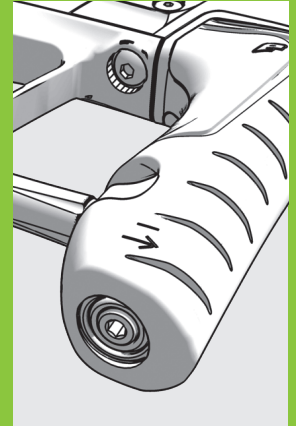
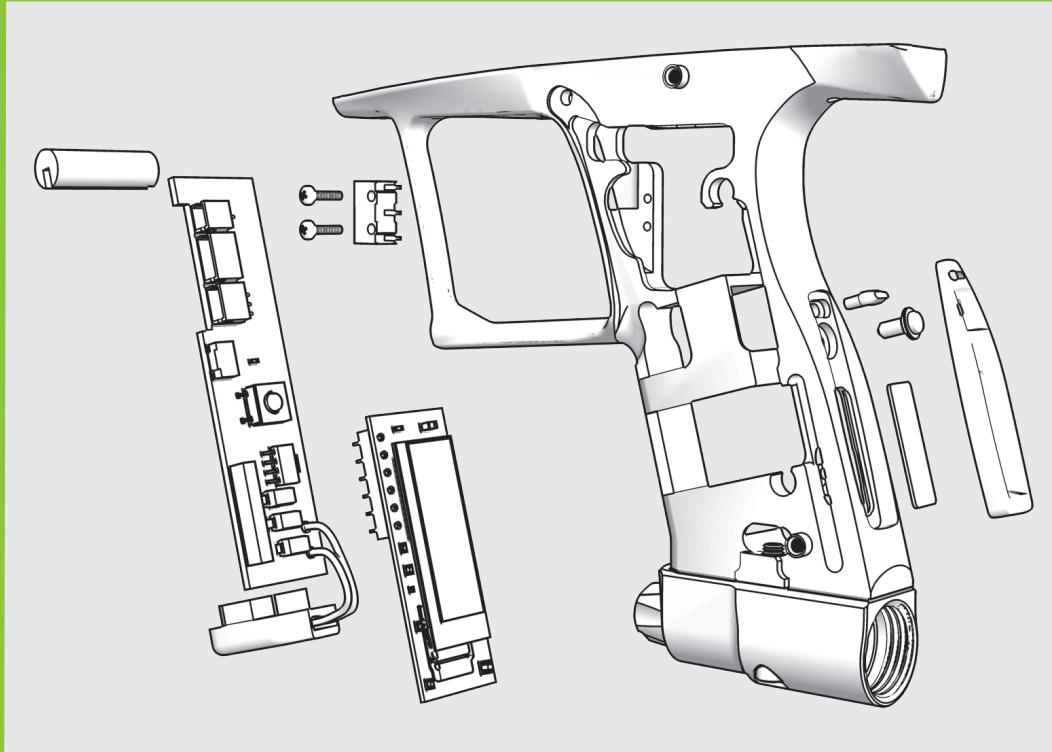

# WARNINGS

## READ CAREFULLY BEFORE USE

**! THE PLANET ECLIPSE GTEK 160R IS NOT A TOY. PAINTBALL SAFETY RULES MUST BE FOLLOWED AT ALL TIMES.**

**!** Careless or improper use of the GTEK 160R, including failure to follow instructions and warnings within this User Manual could cause serious injury or death.

**!** Do not remove or deface any warnings attached to the GTEK 160R.

**!** Paintball industry standard eye/face/ear and head protection designed specifically to stop paintballs and meeting ASTM standard F1776 (USA) or CE standard (Europe) must be worn by the user and any person within range. Proper protection must be worn during assembly, cleaning and maintenance.

**!** Hearing protection should be worn.

**!** Never shoot at a person who is not wearing proper protection.

**!** Never look directly into the barrel of the marker. Accidental discharge into the eyes may cause permanent injury or death. Never look into the barrel or breech area of the GTEK 160R whilst the marker is switched on and able to fire.

**!** The electronic On/Off button is the marker's disabling device, also known as the 'safety'. Always switch off the GTEK 160R when not in use and only switch on when ready to shoot.

**!** Treat every marker as if it is loaded and ready to fire.

**!** Always fit a barrel-blocking device to the GTEK 160R when not in use.

**!** Always remove paintballs from the GTEK 160R when not in use.

**!** Do not field strip or remove any parts while the marker is pressurised.

**!** Do not pressurise the GTEK 160R without all the components of the marker correctly installed, as high-pressure gas may be emitted.

**!** Do not fire the GTEK 160R without the bolt correctly installed.

**!** Never put your finger or any foreign objects into the paintball feed tube of the GTEK 160R.

**!** Never allow pressurised gas to come into contact with any part of your body.

**!** Always remove the first stage regulator and relieve all residual gas pressure from the GTEK 160R before disassembly.

**!** Always remove the first stage regulator and relieve all residual gas pressure from the GTEK 160R for transport and storage.









**!** Always follow the guidelines given with your first stage regulator for safe transportation and storage.

**!** Always store the GTEK 160R in a secure place.

**!** Observe all local and national laws, regulations and guidelines.

# WARNINGS

## READ CAREFULLY BEFORE USE

-  Persons under 18 years of age must have adult supervision when using or handling the GTEK 160R.
-  Only use professional paintball fields where codes of safety are strictly enforced.
-  Only use compressed air/nitrogen. Do not use any other compressed gas or pressurised liquid including CO2.
-  Always follow instructions, warnings and guidelines given with any first stage regulator you use with the GTEK 160R.
-  Use 0.68 inch calibre paintballs only.
-  Always measure your marker's velocity before playing paintball, using a suitable chronograph.
-  Never shoot at velocities in excess of 300 feet (91.44 metres) per second, or at velocities greater than local or national laws allow.
-  Any installations, modifications or repairs should be carried out by a qualified individual at a licensed and insured paintball facility.

### WARNING!



This user manual must accompany the product in the event of resale or new ownership. Should you be unsure at any stage you must seek expert advice.



#### **This Users Manual is in English.**

It contains important safety guidelines and instructions. Should you be unsure at any stage, or unable to understand the contents of this manual you must seek expert advice.



#### **Le mode d'emploi est en Anglais.**

Il contient des instructions et mesures de sécurité importantes. En cas de doute, ou s'il vous est impossible de comprendre le contenu du mode d'emploi, demandez conseil à un expert.



#### **Este manual de usuarios (operarios)**

Usuarios está en Inglés. Contiene importantes normas de seguridad e instrucciones. Si no está seguro de algún punto o no entiende los contenidos de este manual debe consultar con un experto.



#### **Diese Bedienungs - und Benutzeranleitung ist in Englisch.**

Sie enthält wichtige Sicherheitsrichtlinien und -bestimmungen. Sollten Sie sich in irgendeiner Weise unsicher sein, oder den Inhalte dies Heftes nicht verstehen, lassen Sie sich bitte von einen Experten beraten.

### QUICK START (06-16)

- 06 Setting up the GTEK 160R
- 08 Switching the GTEK 160R On/Off
- 09 OLED indicators
- 10 Switching the GTEK 160R On/Off (LED)
- 11 LED indicators
- 12 Velocity adjustment
- 13 Trigger adjustment
- 14 Unloading the GTEK 160R
- 16 Storage and transportation

### MAINTENANCE

- 17 On-line maintenance videos

### ELECTRONICS (18-23)

- 18 The OLED set-up mode
- 19 OLED parameters
- 22 The LED set-up mode
- 23 LED parameters

### RESET (24-25)

- 24 Factory reset
- 25 Installing a 9V battery

### FAULT FINDING (26-29)

- 26 Fault finding tables

### TECHNICAL INFORMATION (30-41)

- 30 Parts list
- 32 Tournament lock button
- 33 AT pipe (Air Transfer pipe)
- 34 SL4 inline regulator
- 35 GTEK 160R bolt assembly
- 36 Solenoid assembly
- 37 On/Off Purge System (OOPS) assembly
- 38 Trigger assembly
- Clamping feed tube assembly
- 39 GTEK 160R circuit board
- GTEK 160R OLED board
- 40 Frame assembly
- 41 Breech Sensor (BS) assembly

### SUPPORT (42-47)

- 42 Index
- 43 Our promise
- 44 Notes
- 45 Warranty card
- 47 Notes

# WE GOT YOUR BACK!

OUR ARMY OF PLANET ECLIPSE PRO TECHS ATTEND PAINTBALL EVENTS ALL OVER THE WORLD TO MAKE SURE THAT YOU AND YOUR ECLIPSE MARKER ARE FIRING ON ALL CYLINDERS, AT ALL TIMES.



FOLLOW OUR OFFICIAL PLANET ECLIPSE SOCIAL MEDIA CHANNELS TO KEEP UP TO DATE WITH OUR TECH SUPPORT EVENTS CALENDAR.



# QUICK START

## SETTING UP THE GTEK 160R

FIG-1

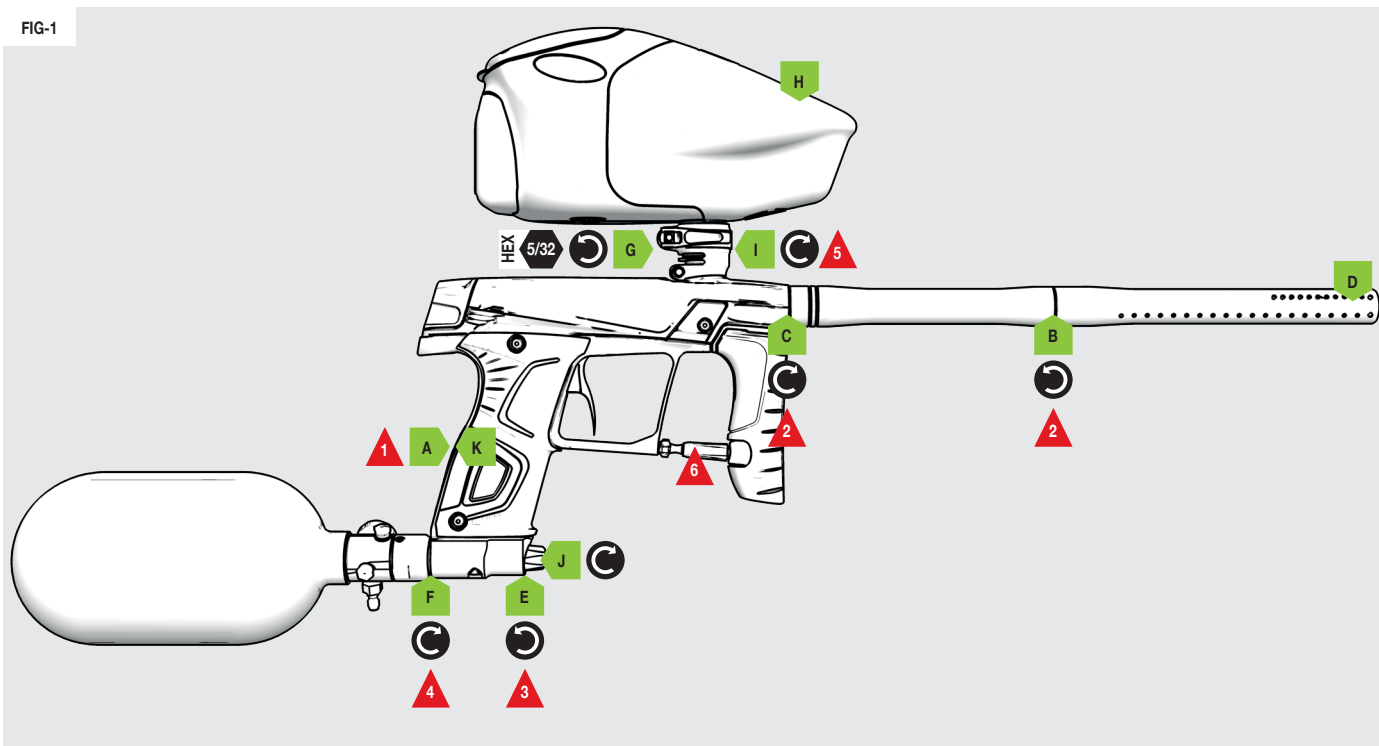

# QUICK START

## SETTING UP THE GTEK 160R

### FIG-1

- A Ensure the marker is switched off before you begin.**
- B Screw both ends of the barrel together.**  
Screw the barrel tip counter-clockwise onto the barrel back.
- C Screw the complete barrel to the marker.**  
The barrel back screws clockwise into the marker body.
- D Fit a barrel blocking device for safety.**
- E Ensure the marker is de-gassed.**  
Unscrew the On/Off Purge System (OOPS) knob counter-clockwise.
- F Attach the pre-set air system.**  
Screw the air system clockwise into the OOPS body.
- G Loosen the clamping feed neck.**  
Open the feed neck lever away from the feed neck.  
Unscrew the feed neck lever screw counter-clockwise.
- H Attach the loader.**  
If the feed neck is too tight, loosen the clamping feed neck more.
- I Secure the loader.**  
Close the feed neck lever to secure.  
Screw the feed neck lever screw clockwise to tighten.
- J Gas the marker.**  
Screw the On/Off Purge System (OOPS) knob clockwise.
- K Switch on the GTEK 160R.**

- 1 IMPORTANT!** To switch On/Off, see pages 8-11.
- 2 DO NOT** over-tighten the barrel.
- 3 ALWAYS** ensure the marker is de-gassed when setting up.
- 4 NEVER** use CO2. Compressed air or Nitrogen only.
- 5 DO NOT** over-tighten the feed neck. This may damage the marker.
- 6 IMPORTANT!** Ensure the AT pipe is correctly installed.

## WARNING!



Always ensure that the marker is off with a barrel blocking device installed and that no paintballs are in the GTEK 160R or loader before installing an air system.

Compressed air and nitrogen systems can be extremely dangerous if handled or used incorrectly.

Only attach an air system certified for use within the country of use.

Never add lubricants or grease into the fill adaptor of the air system regulator.

Ensure that all screws are tightened and no parts are loose before installing an air system.

Do not pressurise the GTEK 160R without the bolt system correctly installed, as high pressure gas will be emitted.

Do not install a compressed air system or load paintballs into the GTEK 160R until you feel confident with your ability to handle the marker safely and responsibly.

# QUICK START

## SWITCHING THE GTEK 160R ON/OFF

The navigation console **A** houses the Select button **B**, the LED indicator **C** and the OLED display **D**. Use the console to switch the GTEK 160R On/Off and change the marker settings.

The LED indicator provides secondary functionality in the event of any OLED board issues you may have (see pages 22-23).

### FIG-1

#### Switching on the GTEK 160R

Press and hold the Select button. Release the Select button when the OLED display and LED light up and your GTEK 160R will begin its power up sequence.<sup>1,2</sup>

#### Firing the GTEK 160R

Pull the trigger to fire the GTEK 160R. If the marker is able to fire then it will do so.

#### Switching off the GTEK 160R

Press and hold the Select button until the display shows GOODBYE and the LED turns red. Release the Select button.

- 1 When the GTEK 160R is turned on, the breech sensor is automatically enabled.
- 2 The LED colours displayed during the power up sequence may vary depending on where the marker was originally purchased.

FIG-1

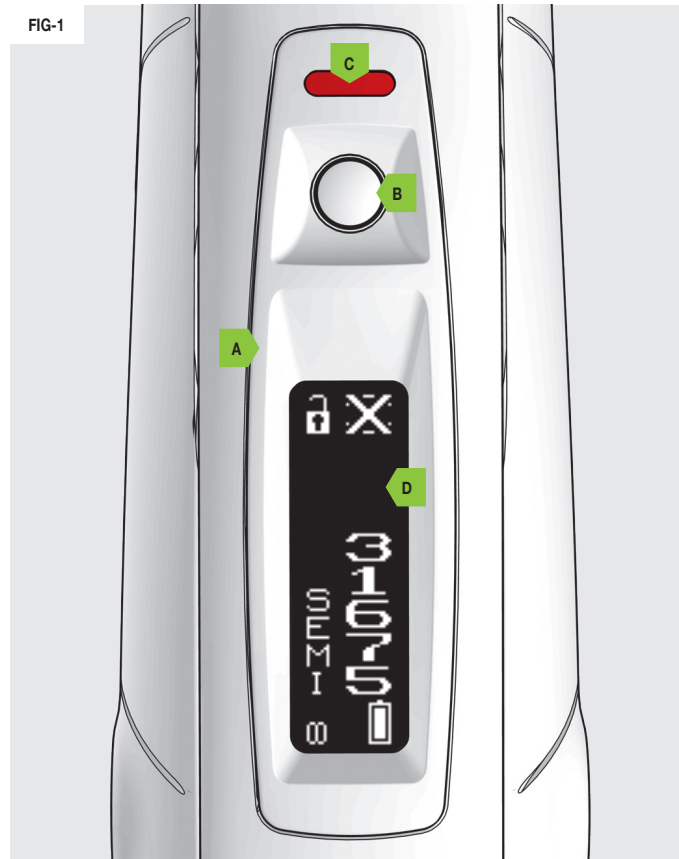

## WARNING!



Do not dry fire/shoot the marker without paintballs. Prolonged dry firing may lead to damage/wear of the internal components of the marker.



FIG-1

The breach sensor (BS) indicator **A** shows the following information:



### BS Enabled and ball detected

The GTEK 160R can be fired up to the BS ON ROF (see page 19).



### BS Enabled no ball detected

The GTEK 160R cannot be fired.



### BS Disabled

The GTEK 160R can be fired up to the BS OFF ROF (see page 19).



### BS Fault detected

System is disabled. The GTEK 160R can only be fired at a reduced maximum rate of fire.

The battery level indicator **B** shows the following information:



### Full battery

The battery is fully charged.



### Drained battery

Battery is at approximately 30% of useful charge.



### Battery circuit fault

The battery level cannot be determined.

For more information about the shot counter **D** and firing modes **E** and **F** see pages 18-19.

FIG-1

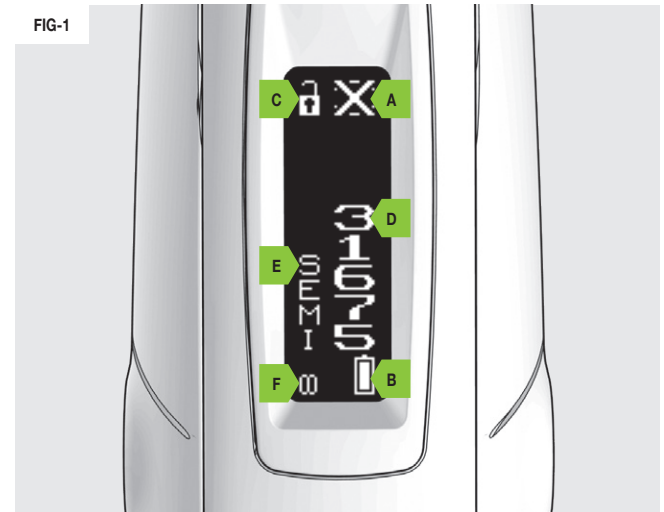

The lock indicator **C** shows the following information:



### Locked

Set-up mode cannot be accessed.  
This is the tournament legal state.



### Unlocked

Set-up mode can be accessed.

To change the tournament lock state see page 32.

## WARNING!



When the battery indicator is being displayed the marker is still on and will fire if the trigger is pulled - depending on the BS status.

# QUICK START

## SWITCHING THE GTEK 160R ON/OFF (LED)

If the OLED board is unplugged from the GTEK 160R circuit board it is still possible to operate the marker.

**FIG-1**

To switch the GTEK 160R on press and hold the Select button **A**. Release the Select button when the LED **B** lights up and the power up sequence will begin. At the end of the power up sequence the LED Indicator will show the status of the breach sensor (see table 1).<sup>1, 2</sup>

**TABLE 1**

LED COLOUR	BREACH SENSOR (BS) STATUS
FLASHING YELLOW	BS enabled. NO paintball detected. <b>Marker WILL NOT fire.</b>
FLASHING LIGHT BLUE	BS enabled. Paintball detected. <b>Marker WILL fire.</b>
FLASHING PURPLE (SLOW)	BS disabled. <b>Marker WILL fire.</b>
FLASHING PURPLE (FAST)	Blockage detected. BS disabled. <b>Marker WILL fire.</b>

To switch the GTEK 160R off press and hold the Select button. Release the Select button when the LED turns red. The GTEK 160R will now switch off.

- 1 When the GTEK 160R is turned on, the breach sensor is automatically enabled.
- 2 The LED colours displayed during the power up sequence may vary depending on which part of the world the marker was originally purchased.

**FIG-1**



### FIG-1

Periodically, every 6 seconds or so, the LED indicator **B** will show the battery status with a steady colour for 1 second.

You can also check the battery status at any time when the marker is switched on:

- 1 Tap the Select button **A**.
- 2 The LED indicator **B** will turn a steady colour for 1 second.

Table 2 (below) shows each LED colour and its relevant battery status.

**TABLE 2**

LED COLOUR	BATTERY STATUS
GREEN	Battery level is good.
YELLOW	Battery level is low.
RED	Replace the battery.

The LED also indicates the various marker parameter settings.

See pages 22-23 for marker parameter LED indicators.

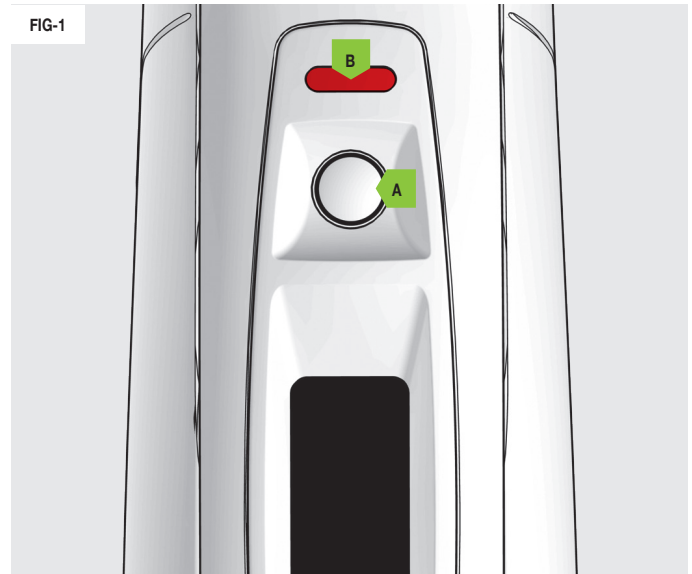

### Firing the GTEK 160R

Pull the trigger to fire the GTEK 160R. If the marker is able to fire then it will do so.

## WARNING!



When the battery indicator is being displayed the marker is still on and will fire if the trigger is pulled - depending on the BS status.

Do not dry fire/shoot the marker without paintballs. Prolonged dry firing may lead to damage/wear of the internal components of the marker.

# QUICK START

## VELOCITY ADJUSTMENT

**FIG-1**

Insert a 1/8 hex key **A** into the velocity adjuster screw **B** to alter the velocity of the GTEK 160R.

- 1 Turn the hex key clockwise to reduce velocity.
- 2 Turn the hex key counter-clockwise to increase velocity.
- 3 Fire two clearing shots after each velocity adjustment for an accurate velocity reading.

**1** **DO NOT** turn the adjuster screw in too far. This will prevent the GTEK 160R from firing.

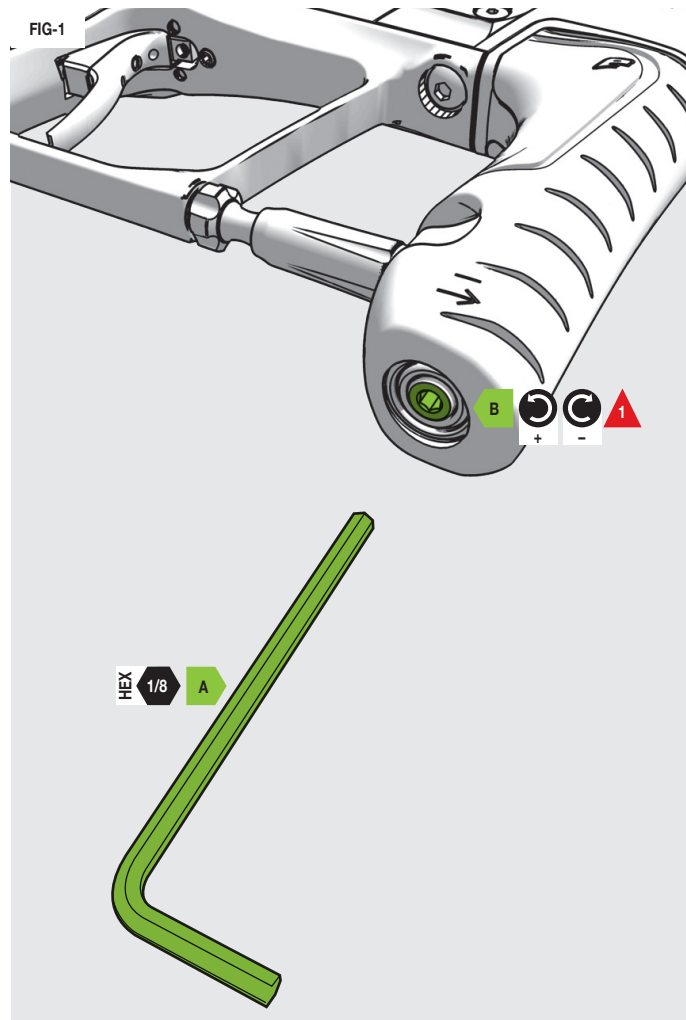

## WARNING!



DO NOT exceed 300FPS.

Always wear correct protective equipment when firing your marker.

NEVER point your marker in the direction of other people when not on the field.

# QUICK START

## TRIGGER ADJUSTMENT

**FIG-1**

The trigger spring screw **A** adjusts the spring strength of the trigger return. Clockwise increases strength, counter-clockwise reduces it.

The trigger shoe retaining screw **B** is only to be removed to change to a new shape trigger shoe (sold separately). Counter-clockwise removes the screw, clockwise tightens it.

The microswitch screw **C** sets the microswitch actuation point. Clockwise reduces it, counter-clockwise increases it.

The pre-travel screw **D** adjusts the distance the trigger travels before the microswitch is actuated. Clockwise reduces the amount of travel, counter-clockwise increases the amount of travel.

The post-travel screw **E** adjusts the distance the trigger travels once the microswitch has been actuated. Clockwise reduces the amount of travel, counter-clockwise increases the amount of travel.

### WARNING!



Always make sure the marker is OFF and de-gassed with a barrel blocking device installed and no paintballs are in the marker or loader before adjusting the trigger.

Do not wind the screws in too far as this may prevent the GTEK 160R from firing or even damage the marker.

If the pre-travel screw and/or the microswitch screw is wound in too far this could cause the GTEK 160R to fire unintentionally.

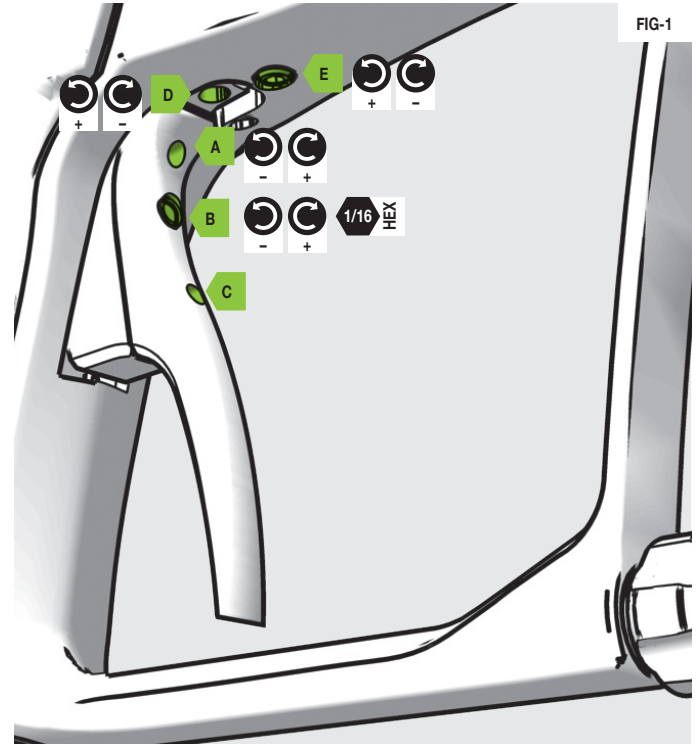

# QUICK START

## UNLOADING THE GTEK 160R

FIG-1

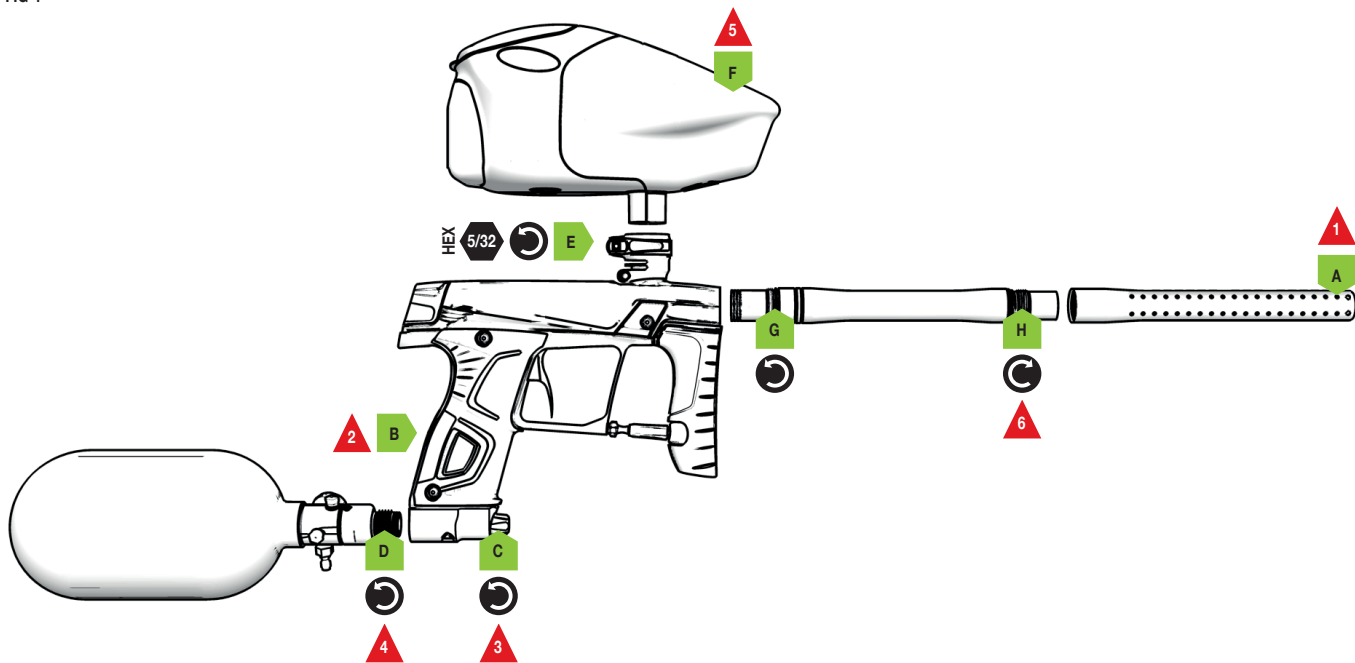

# QUICK START

## UNLOADING THE GTEK 160R

### FIG-1

- A Ensure that a barrel blocking device is fitted for safety.**
- B Switch the marker off.**
- C De-gas the marker.**  
Unscrew the On/Off Purge System (OOPS) knob counter-clockwise.
- D Remove the pre-set air system.**  
Unscrew the air system counter-clockwise from the OOPS body.
- E Loosen the clamping feed neck.**  
Open the feed neck lever away from the feed neck.  
Unscrew the feed neck lever screw counter-clockwise.
- F Remove the loader.**  
If the feed neck is too tight, loosen the clamping feed neck more.
- G Remove the barrel from the marker body.**  
Unscrew counter-clockwise to remove.
- H Remove the barrel tip from barrel back.**  
Unscrew clockwise to remove.

- 1 IMPORTANT!** Extra precaution to avoid injury.
- 2 IMPORTANT!** To switch Off/On, see pages 8-11.
- 3 IMPORTANT!** Always de-gas before unloading.
- 4 IMPORTANT!** Always remove air system before unloading.
- 5 IMPORTANT!** Always remove any paintballs from the breech of the marker once the loader has been removed.
- 6 IMPORTANT!** Unscrew the barrel tip CLOCKWISE to remove.

## WARNING!



Always make sure the marker is off with a barrel blocking device installed and that no paintballs are in the GTEK 160R or loader before unloading.

Compressed air and nitrogen systems can be extremely dangerous if handled or used incorrectly.











NEVER leave the GTEK 160R gassed up when unloading.

NEVER point your marker in the direction of other people when not on the field.

Remove any paintballs from the breech before storing your GTEK 160R.

# QUICK START

## STORAGE AND TRANSPORTATION

-  1 Your GTEK 160R must be clear of all paint and propellant during transportation or storage.
-  2 Make sure the GTEK 160R marker is switched off.
-  3 Remove the barrel from the marker.
-  4 Make sure the marker is clean of any paint residue, dirt and moisture.
-  5 Store your GTEK 160R in a clean, cool, dry place.
-  6 Keep your GTEK 160R away from any unauthorized and unsafe users.
-  7 Remove the battery when storing your GTEK 160R to prevent unauthorized use.
-  8 Protect your GTEK 160R from excessive heat during transportation.
-  9 When transporting a paintball marker by air, check with the airline regarding their policies on transporting paintball equipment as hold luggage before arriving at the airport.
-  10 Observe and obey all local and national laws concerning the transportation of paintball markers.
-  11 Use the box in which the marker was originally supplied to protect the marker against rough handling during transport.

## WARNING!

Never carry your GTEK 160R un-cased when not on a playing field. The non-playing public and law enforcement personnel may not be able to distinguish between a paintball marker and a real firearm. For your own safety and to protect the image of paintball, always carry the GTEK 160R (or any other paintball marker) in a suitable marker case such as the one in which it was supplied.





# MAINTENANCE

## ON-LINE MAINTENANCE VIDEOS

To help demonstrate how to maintain and service essential parts of the GTEK 160R we've created a collection of dedicated marker maintenance videos to guide the user through each step.

From basic, to more advanced parts of the GTEK 160R, we've got your back.

Visit our **Tech Room** YouTube channel and check out the GTEK 160R Maintenance playlist.

For all of our GTEK160R (and other markers) maintenance videos check out the Planet Eclipse Tech Room YouTube channel:

[YOUTUBE.COM/PLANETECLIPSETV](https://www.youtube.com/planetclipsetv)

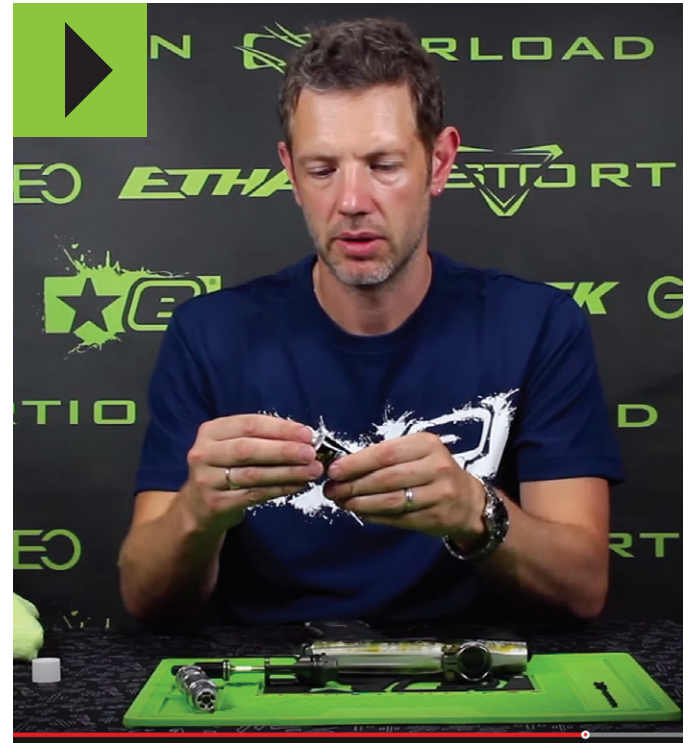



### PRESET

Modes may vary depending on global location and GTEK 160R model.

- 1 **SEMI ∞**  
Uncapped Semi-Automatic: one shot per trigger pull (no rate of fire cap).
- 2 **SEMI 15.0**  
Capped Semi-Automatic: one shot per trigger pull (15.0bps cap).
- 3 **WPBO 10.2**  
Capped Ramping: WPBO compliant\* (10.2bps cap).
4. **NXL 10.2**  
Capped Ramping: NXL compliant\* (10.2bps cap).
5. **MILL 10.2**  
Capped Ramping: Millennium Series compliant\* (10.2bps cap).
6. **PSP 10.2**  
Capped Ramping: PSP compliant (10.2bps cap).



The rate of fire cap is deliberately set lower than the league rules allow in order to compensate for any tolerances in the rate of fire measuring devices.

\*At the time of writing, the WPBO, NXL and MILL presets are identical.

### BS ON ROF

This controls how fast the GTEK 160R can fire with the breech sensor on. Capped modes only.

Available range: 4.0 - 15.0 bps

Default setting: 15.0 bps



### BS OFF ROF

This controls how fast the GTEK 160R can fire with the breech sensor off. This should be set to the slowest speed of the loader.

Available range: 4.0 - 15.0 bps

Default setting: 10.0 bps



### KICK IN

The trigger pulls per second (pps) before ramping can start.

Available range: 3.3 - 10.0 pps

Default setting: 5.0 pps



### DWELL

Solenoid energise time in milliseconds (ms) for each shot.

Available range: 18.0 - 28.0 ms

Default setting: 23.0 ms



### RESTART

The time in seconds (s) after the last trigger pull before ramping can start.

Available range: 0.0 - 1.0 s

Default setting: 0.0 s



### DEBOUNCE

Trigger anti-bounce settings.  
(1 = lowest level of filtering / 10 = highest level).

Available range: 1 - 10

Default setting: 5



### SLEEP

Auto power-off time in minutes (min).

Available range: 0 - 60 min

Default setting: 20 min



### DISPLAY

Sets the display information for the run screen.

**SHOTS:** Displays the shot counter

**ROF:** Displays the ROF indicator



### ZERO

Allows the user to reset the counters and indicators to ZERO.

**NONE:** Don't zero anything

**SHOTS:** Zero the shot counter

**ROF:** Zero the ROF indicator

**BOTH:** Zero shot counter and the ROF indicator

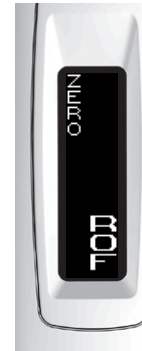

If the OLED module is unplugged from the main circuit board it is still possible to modify the GTEK 160R parameters using the LED interface. To enter the set-up mode:

- 1 Switch the tournament lock off (page 32).
- 2 Fully depress the trigger.
- 3 Switch on the GTEK 160R (with trigger depressed).
- 4 Release the trigger.
- 5 If the LED flashes red, the tournament lock is still on.

Once in the set-up mode, use the trigger to cycle through the parameters, indicated by LED colours (see table below). Quickly press the Select button on any parameter to display the current settings.

LED COLOUR	PARAMETER	RANGE
RED	Pre-set	1 to 6
GREEN	Maximum ROF with BS on (capped modes only)	4.0 to 15.0 bps
BLUE	Maximum ROF with BS off	4.0 to 15.0 bps
PURPLE	Dwell	18.0 ms to 28.0 ms
LIGHT BLUE	Debounce	1 to 10

A long LED flash indicates the unit, whilst a short LED flash indicates the tenth. Eg, 5 long flashes and 3 short flashes would indicate 5.3.

### Modifying a parameter:

- 1 Enter the set-up mode.
- 2 Select a parameter.
- 3 Push and hold Select button for 1 second to confirm.
- 4 The LED will go off.
- 5 Increase the unit value using the trigger, one pull per unit. Do not pull the trigger if the value should be 0.<sup>1</sup>
- 6 Push the Select button to switch to tenths values.<sup>2</sup>
- 7 Increase the tenths value using the trigger, one pull per tenth. Do not pull the trigger if the value should be 0.
- 8 Push the Select button to confirm. The LED will flash 3 times. The LED will show green if the changes are confirmed. The LED will show red if the changes are NOT confirmed. If the LED is red repeat 5.
- 9 Push and hold the Select button until the LED turns blue to exit set-up mode.

1 The settings will return to their previous saved values if you do not pull the trigger for 5 seconds.

2 If a parameter does not support tenths, this will be skipped.

The LED indicator communicates with the user through colour.

This overview page explains each colour and their roles once you enter the set-up mode (see page 22).

LED COLOUR	PARAMETER	DESCRIPTION
RED	SEMI ∞	Uncapped Semi-Automatic: one shot per trigger pull (no rate of fire cap).
	SEMI 15.0	Capped Semi-Automatic: one shot per trigger pull (15.0bps cap).
	WPBO 10.2	Capped Ramping: WPBO compliant (10.2bps cap).
	NXL 10.2	Capped Ramping: NXL compliant (10.2bps cap).
	MILL 10.2	Capped Ramping: Millennium Series compliant (10.2bps cap).
	PSP 10.2	Capped Ramping: PSP compliant (10.2bps cap).
<b>PLEASE NOTE:</b> At the time of writing, the WPBO, NXL and MILL presets are identical.		
GREEN	Maximum ROF (BS ON)	This controls how fast the GTEK 160R can fire with the breech sensor on. Capped modes only.
BLUE	Maximum ROF (BS OFF)	This controls how fast the GTEK 160R can fire with the breech sensor off. This should be set to the slowest speed of the loader.
PURPLE	Dwell	This controls the amount of time that the solenoid is energised.
LIGHT BLUE	Debounce	This controls the amount of 'anti-trigger bounce' that is present.
FLASHING BLUE	Factory reset	Press and hold the tournament lock button (page 32) for 2 seconds to restore all settings back to factory standard. The LED will flash blue to confirm this has been successful.

# RESET FACTORY RESET

It is important that the GTEK 160R is set-up as per factory standards before use. To restore to factory settings, follow these steps.

## FIG-1

- 1 Press and hold the tournament lock button (see page 32) for 2 seconds to reset all control parameters.
- 2 Using the 1/8 hex key **A** turn the inline regulator **B** screw 4 turns clockwise from it's fully screwed-out position.

**1** **DO NOT** turn the adjuster screw in too far. This will prevent the GTEK 160R from firing.

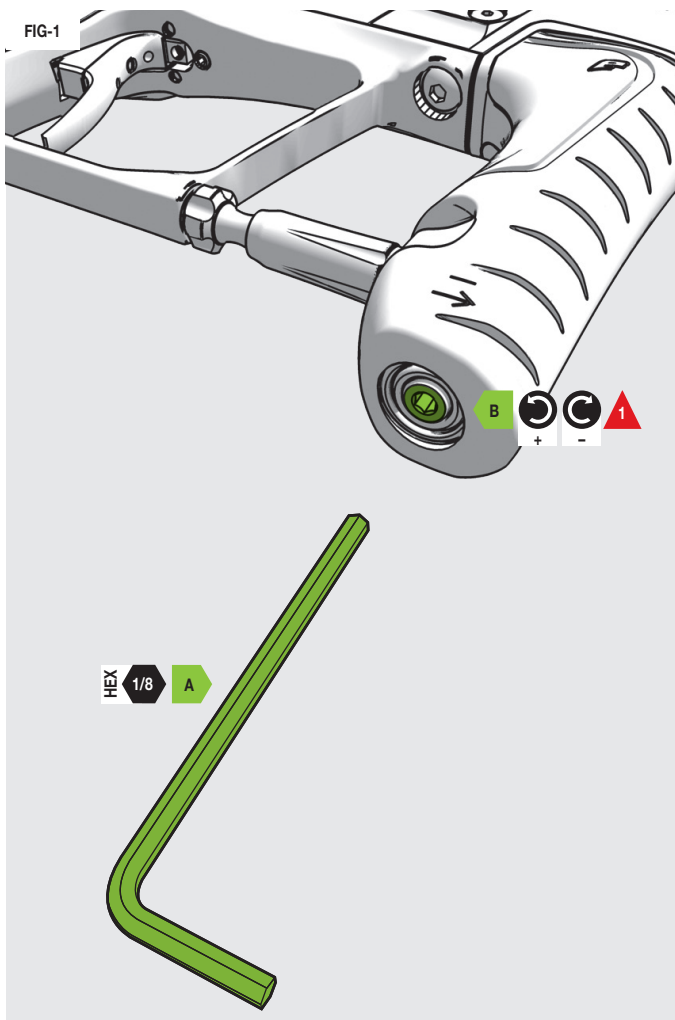



# RESET

## INSTALLING A 9V BATTERY

Switch off the GTEK 160R and place on a flat surface - feed neck facing away from you and the barrel pointing to the right.

### FIG-1

Using the 5/64" (2mm) hex key **A** remove the grip screws on the right hand side of the grip.

### FIG-2

Gently remove the 9V battery using the recessed access point **B**.

Install a new 9V Alkaline battery (type PP3, 6LR61, 1604A) with the battery connectors **C** facing downwards inside the frame.

Replace the rubber grips and tighten the screws as in **FIG-1**.

**1** **DO NOT** over-tighten the screws.

**2** **DO NOT** use re-chargeable or poor quality batteries.

## WARNING!



Do not submerge any of the electronics in water as this may present an electric shock and/or fire hazard.

Check with your local waste disposal authority with regards to the disposal or recycling of your used batteries.

FIG-1

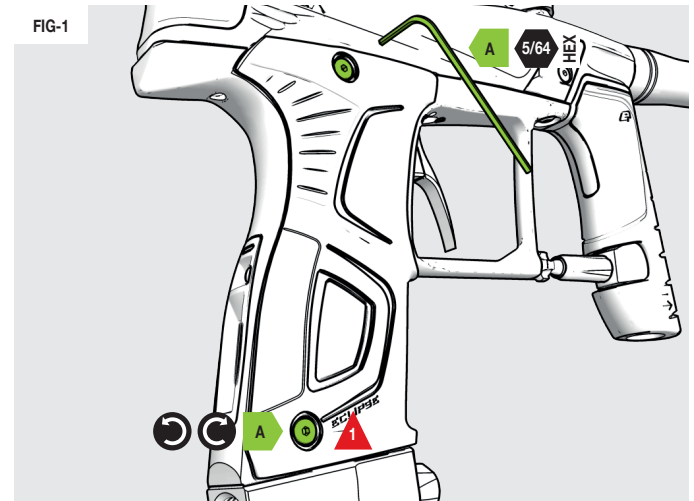
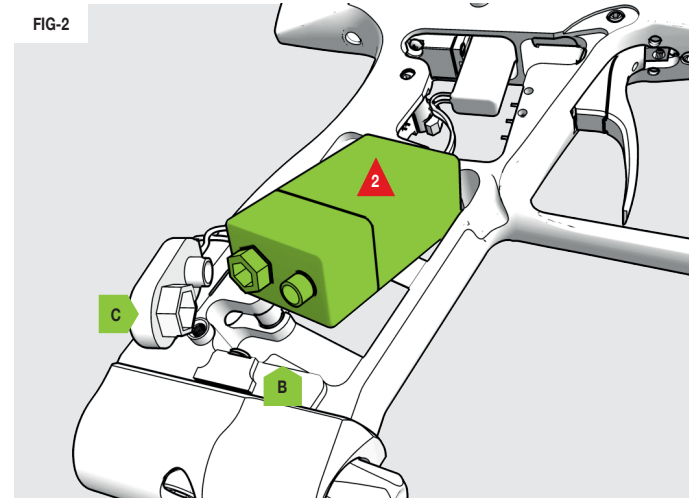

FIG-2



# FAULT FINDING

## FAULT FINDING TABLES

SYMPTOM	POSSIBLE CAUSE	SOLUTION
Although a fresh battery has been fitted, the GTEK 160R will not switch on.	The battery has drained on the shelf.	Replace with another battery.
	The battery connector is not making proper contact with the battery.	Disconnect the battery. Gently squeeze the large terminal on the battery connector to reduce its diameter. Reconnect the battery.
The battery does not seem to last very long.	The battery type is of a low quality.	Use an alkaline or lithium battery. Do not use a low quality or rechargeable battery.
When switched on, the GTEK 160R displays SETUP or LOCKED.	The trigger is depressed.	Release the trigger or unscrew the trigger microswitch screw.
The GTEK 160R leaks from the solenoid and/or manifold.	The two o-rings under the solenoid body or the gasket under the solenoid plate are damaged or dirty.	Ensure the gasket is seated correctly. Replace the gasket if damaged using GTEK 160R parts kit. Check condition of the 5x1 NBR70 and 3x1 NBR70 o-rings under the solenoid body.
	Solenoid valve and/or manifold are over-pressurised.	Check the output pressure of the inline regulator, adjust accordingly. Clean and inspect the inline regulator assembly paying particular attention to the piston o-ring, piston tip and regulator seal. Replace damaged components as necessary.
	Damaged or incorrect seals on the solenoid spool.	Replace and/or lubricate solenoid spool seals.
	Damaged GTEK 160R SMC solenoid pilot valve.	Replace GTEK 160R SMC pilot solenoid valve.
The GTEK 160R leaks down the barrel.	Dirty or damaged can o-rings.	Clean and lubricate or replace 020 NBR70 and 017 NBR o-rings on the front of the can.
	Dirty or damaged o-rings on the spool.	Clean and lubricate or replace the 011 NBR70 and 012 NBR70 o-rings on the main spool.
	Dirty or damaged bolt o-rings.	Clean and lubricate or replace 14x2 NBR70 o-ring on the back of the bolt.
	Dirty or damaged rear bolt guide o-ring.	Clean and lubricate or replace 014 NBR70 o-ring on the back of the bolt guide.

# FAULT FINDING

## FAULT FINDING TABLES

SYMPTOM	POSSIBLE CAUSE	SOLUTION
Low rate of fire / rate of fire not reaching the ROF cap.	The force setting of the loader is too low.	Adjust the loader force feed setting.
	The breech sensor has detected a fault and reduced the ROF.	Check the position and condition of the breech sensors. Clean or replace the breech sensors as required.
The marker is breaking paintballs in the barrel or breech.	The ball detents are damaged or missing.	Replace the ball detents.
	The force setting of the loader is too high.	Reduce the loader force feed setting.
	The paint is poor quality.	Try a higher grade of paint.
	The breech sensor is switched off.	Switch on the breech sensor.
	The bolt and/or breech sensor is dirty	Clean the bolt and breech sensor.
	The velocity is set too high.	Check and adjust the velocity of the GTEK 160R.
	The paint is too big for the barrel bore size.	Invest in a range of barrels with different bore sizes.
The GTEK 160R does not fire.	The GTEK 160R is not powered up.	Power up the GTEK 160R using the Select button on the back of the GTEK 160R grip frame.
	The OOPS is not fully engaged.	Turn the OOPS knob clockwise until it engages.
	The battery quality or charge level is very low.	Install new high quality alkaline or lithium battery.
	The battery is flat.	Replace the battery.
	The DWELL parameter is set too low.	Increase the DWELL parameter.
	The trigger is set-up incorrectly.	Adjust trigger correctly to fully open and close the microswitch.
	The solenoid is not plugged into the GTEK 160R PCB.	Plug solenoid wire into its port on the GTEK 160R PCB.
	The breech sensor is enabled but there is no paint in the breech.	Fill the loader with paint.
	The PCB is damaged.	Replace PCB.
The solenoid valve is damaged.	Replace solenoid valve.	

# FAULT FINDING

## FAULT FINDING TABLES

SYMPTOM	POSSIBLE CAUSE	SOLUTION
Low constant velocity.	The inline regulator output pressure set too low.	Increase the output pressure of the inline regulator.
High velocity first shot.	The inline regulator pressure is creeping.	Strip and clean the inline regulator replacing the piston seal.
Velocity drop-off during rapid fire.	The battery quality or charge level is low.	Install a new high quality alkaline battery.
	Air system regulator does not have high enough flow.	Try another air system.
	Dirty/partially blocked inline regulator.	Strip, clean, lubricate and rebuild the inline regulator.
The trigger is very "bouncy".	Incorrect filter settings.	Check that your DEBOUNCE settings suit your trigger set-up.
	The trigger pull is too short and the return strength is too low.	See page 13 for trigger adjustment guidelines.
The breech sensor is not reading correctly.	The breech sensor is dirty.	Keep the breech sensor clean to ensure correct readings.
	The breech sensor is fitted incorrectly.	Check that the red receiver is on the right-hand side of the breech and the sensors pointing towards each other through the breech.
	There is a broken wire or contact or a short circuit on either of the breech sensor cables.	Check the plug of the cables. Check for cuts or pinches in the sensor cables.
The breech sensor turns itself off after firing and the display shows that there is a fault with the breech sensor.	The sensor is dirty.	Clean the breech sensor.
	The sensor is faulty.	Replace the breech sensor.
	The sensor is out of place.	Re-install breech sensor. Check alignment.

# FAULT FINDING

## FAULT FINDING TABLES

SYMPTOM	POSSIBLE CAUSE	SOLUTION
Two or more balls are being fed into the breech.	Worn, damaged or missing ball detents.	Change the rubber ball detent.
	The feed force is too high from loader.	Adjust loader settings/use a lower force loader.
GTEK 160R is inconsistent.	The inline regulator is supercharging.	Strip and clean inline regulator, replace regulator seal.
	The DWELL is too low.	Increase the DWELL setting.
	Poor quality paintballs.	Use better quality paintballs.
	Poor paintball size to barrel bore match.	Use a closer paintball to barrel bore size.
	Inconsistent air supply from air system.	Use a good quality air system.
GTEK 160R is inefficient.	Poor paintball size to barrel bore match	Use a closer paintball to barrel bore size.
When the GTEK 160R powers up the display shows SETUP or LOCKED or the LED flashes white or red.	The trigger is being pulled.	Release the trigger before powering on the GTEK 160R.
	Microswitch is permanently depressed by an incorrectly set trigger.	Adjust the trigger so that when the trigger is at rest the microswitch is not being activated (see page 13).

If an issue with the GTEK 160R cannot be solved using the fault finding guide, contact your nearest Eclipse Service Centre for assistance.

# TECHNICAL INFORMATION

## PARTS LIST

FIG-1

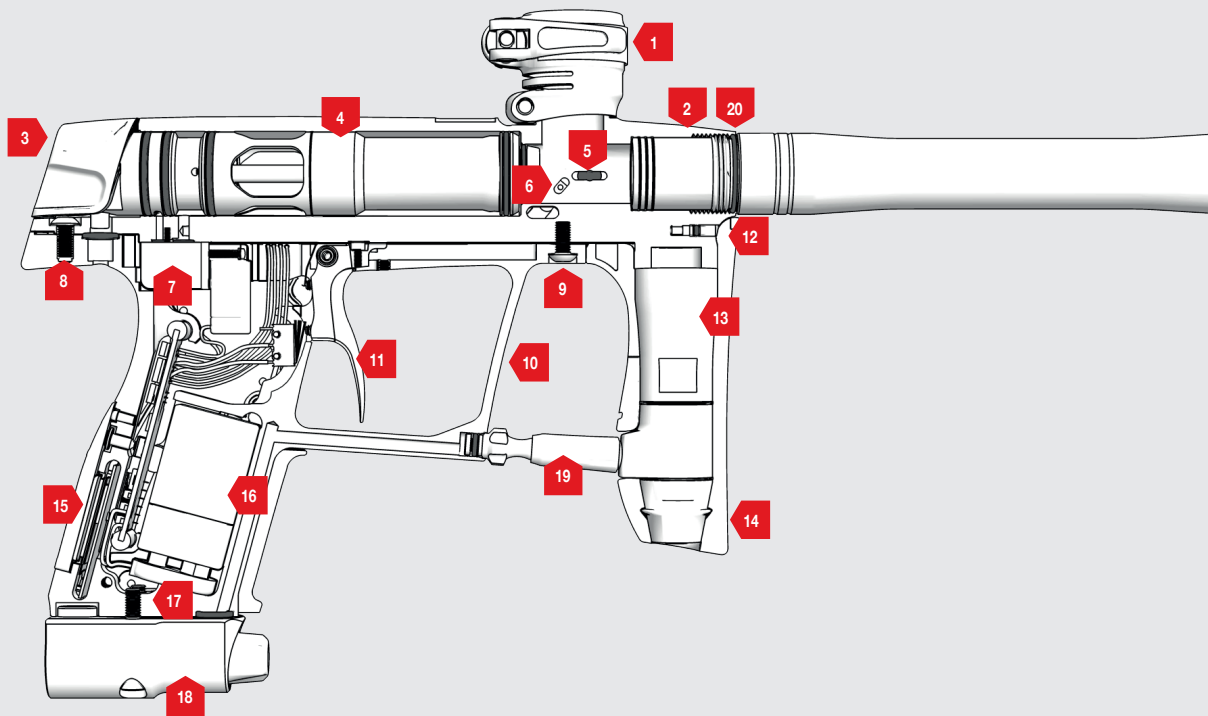

---

**FIG-1**

- |           |                             |           |                                          |
|-----------|-----------------------------|-----------|------------------------------------------|
| <b>1</b>  | Clamping feed tube assembly | <b>11</b> | Trigger assembly                         |
| <b>2</b>  | Marker body                 | <b>12</b> | Body plug                                |
| <b>3</b>  | Quick-release bonnet        | <b>13</b> | SL4 inline regulator assembly            |
| <b>4</b>  | Bolt assembly               | <b>14</b> | Regulator sleeve                         |
| <b>5</b>  | Rubber detent               | <b>15</b> | Navigation console                       |
| <b>6</b>  | Breach sensor (BS) unit     | <b>16</b> | 9V battery                               |
| <b>7</b>  | Solenoid assembly           | <b>17</b> | On/Off Purge System (OOPS) retaining nut |
| <b>8</b>  | Rear frame screw            | <b>18</b> | OOPS assembly                            |
| <b>9</b>  | Front frame screw           | <b>19</b> | AT pipe (Air Transfer pipe)              |
| <b>10</b> | Frame assembly              | <b>20</b> | Barrel o-ring #016 NBR70                 |

# TECHNICAL INFORMATION

## TOURNAMENT LOCK BUTTON

**FIG-1**

To access the tournament lock button use the 5/64" (2mm) hex key **A** remove the grip screws on the left hand side of the grip **B**.

**FIG-2**

The tournament lock button **C** is on the left side of the circuit board (see page 39). To lock / unlock your marker push the button once.

The OLED (or LED) will display the locked / unlocked mode status (see pages 8-11).

Replace rubber grip and screws as per **Fig-1**.

**1** **DO NOT** over-tighten the screws.

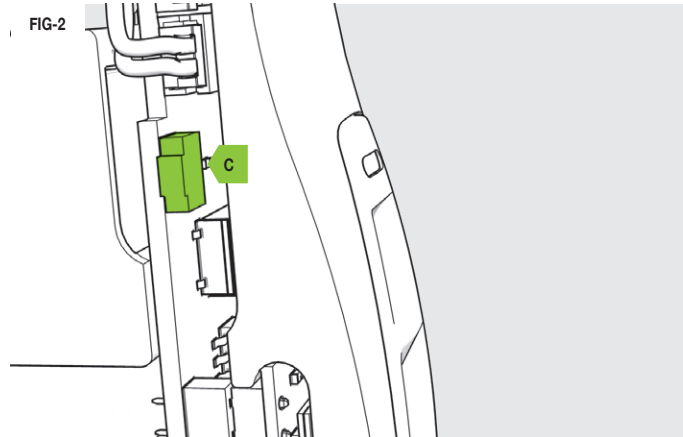
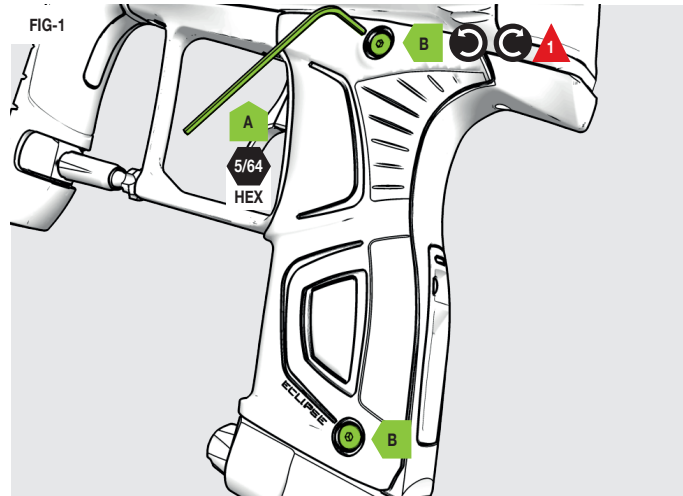

### WARNING!



Always ensure the marker is made safe before changing the tournament lock state to avoid accidentally firing the marker.



# TECHNICAL INFORMATION

## AT PIPE (AIR TRANSFER PIPE)

### FIG-1

The GTEK 160R has a metal frame with an AT pipe (Air Transfer pipe) **A** rather than micro line, for a more streamlined and compact system.

### FIG-2

The AT pipe comprises of two sections. The pipe section **B** screws clockwise (inwards) and anti-clockwise (outwards) of the pipe nut section **C** to securely transfer air from the tank to the regulator.

### FIG-3

The pipe section can screw all the way inwards **D** to make it easy to install and remove the AT pipe. See maintenance videos for more installation/removal information (see page 17).

**!** **NEVER** leave the marker gassed up when adjusting the AT pipe.

## WARNING!



Always make sure the marker is off with a barrel blocking device installed and that no paintballs are in the GTEK 160R or loader.

Compressed air and nitrogen systems can be extremely dangerous if handled or used incorrectly.

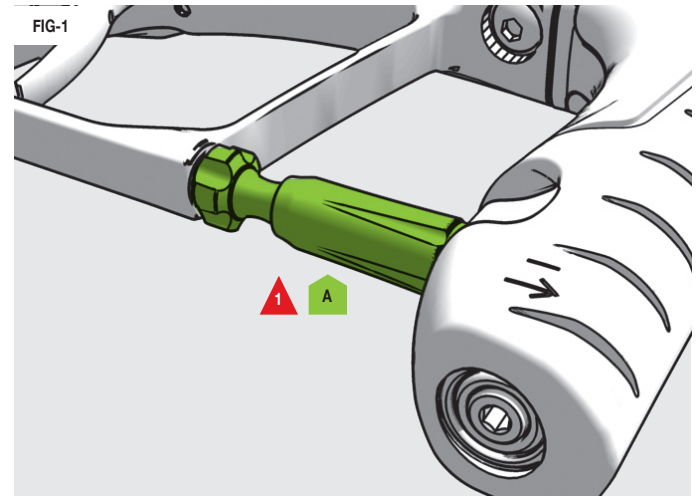

FIG-2

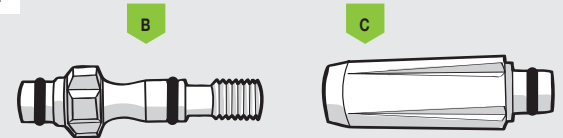
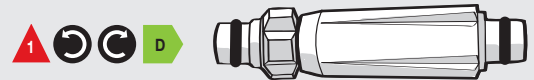

FIG-3



# TECHNICAL INFORMATION

## SL4 INLINE REGULATOR <sup>1,2</sup>

FIG-1

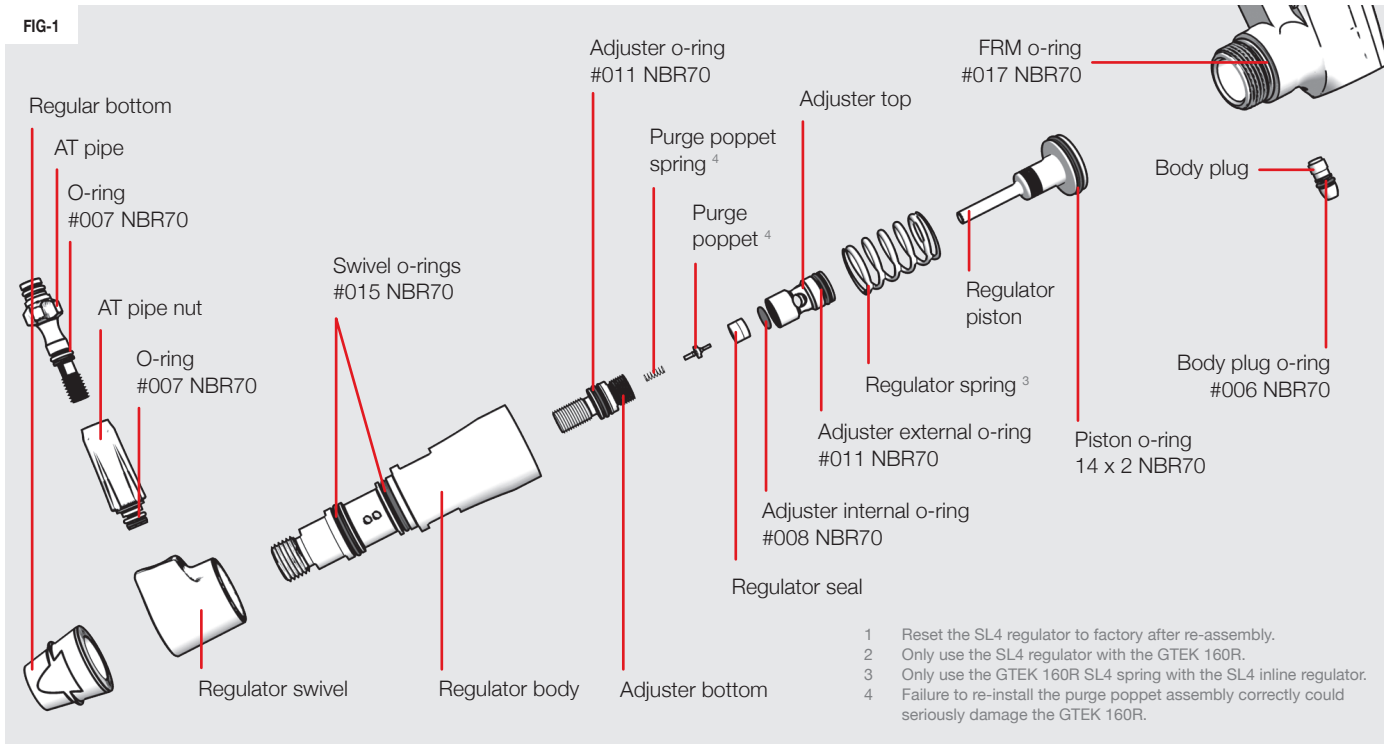

# TECHNICAL INFORMATION

## GTEK 160R BOLT ASSEMBLY

FIG-1

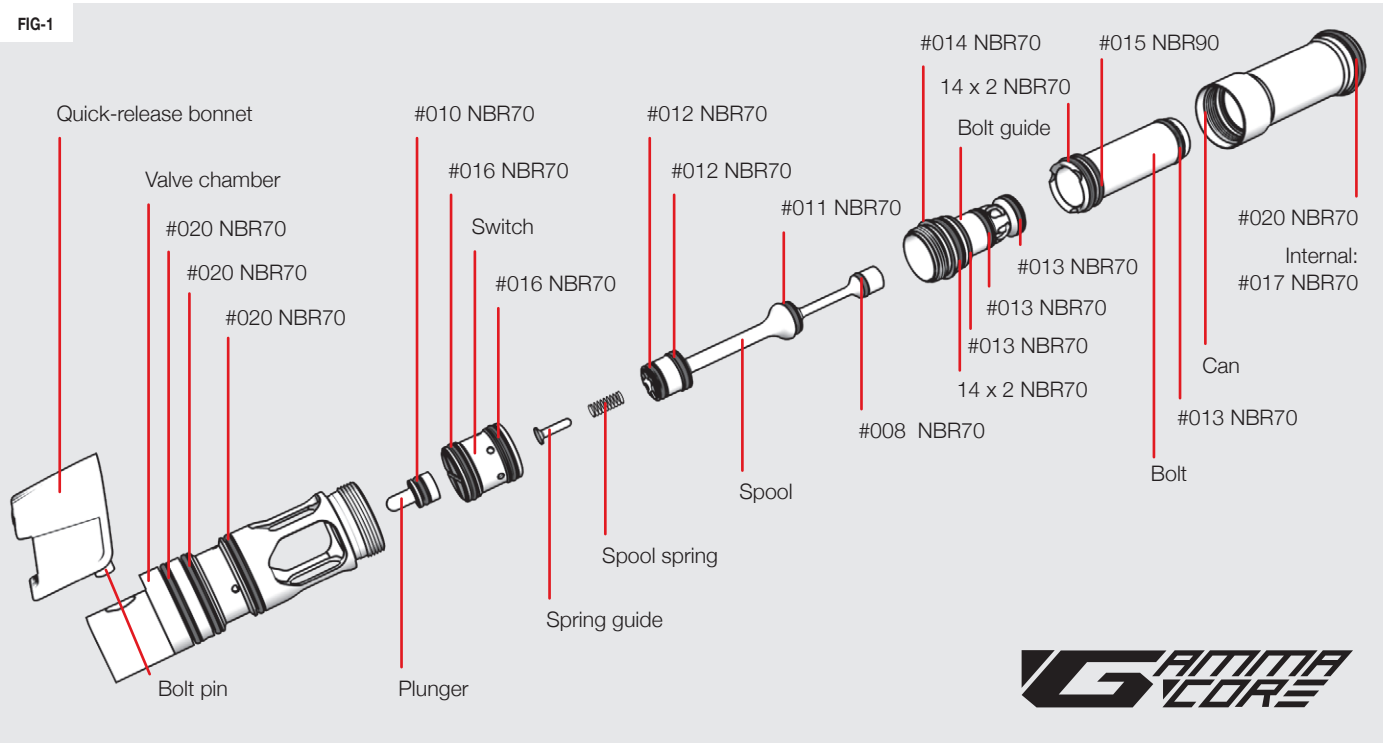

# TECHNICAL INFORMATION

## SOLENOID ASSEMBLY

FIG-1

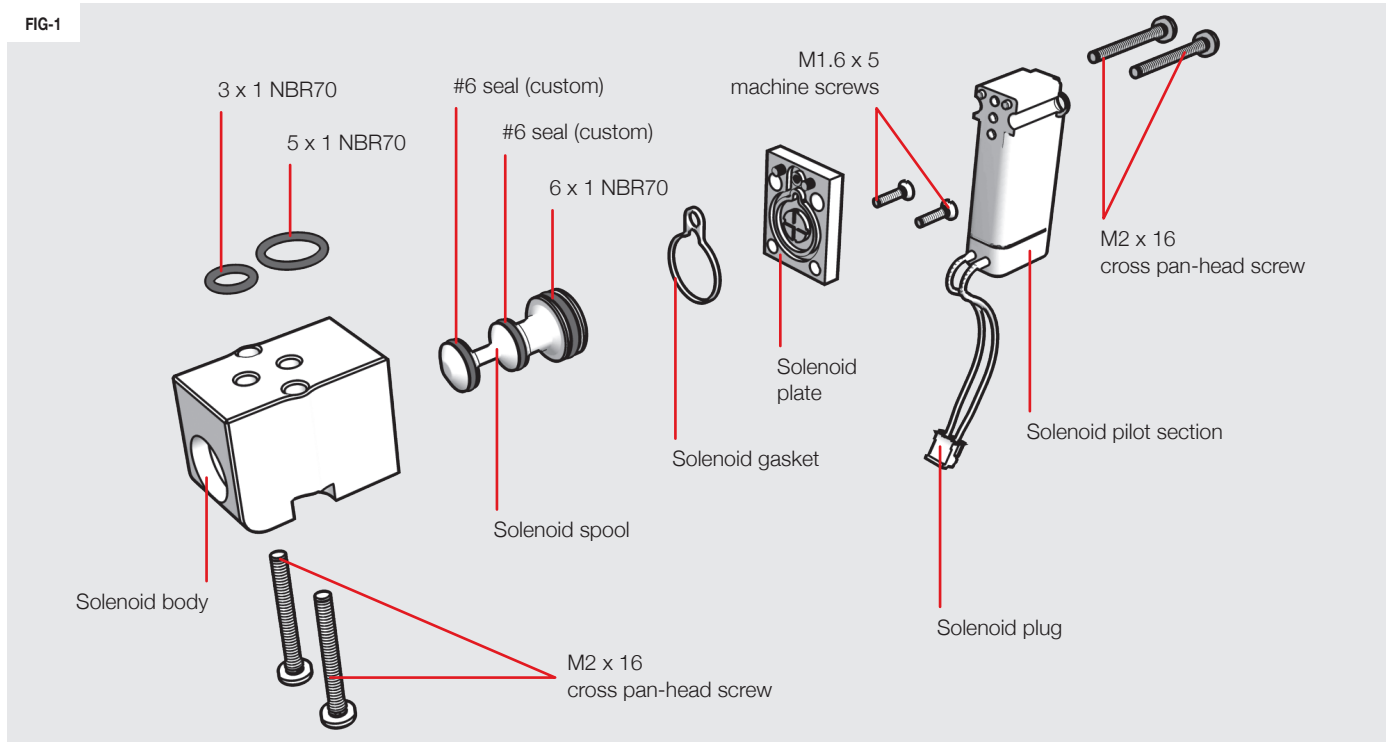

# TECHNICAL INFORMATION

## ON/OFF PURGE SYSTEM (OOPS) ASSEMBLY

FIG-1

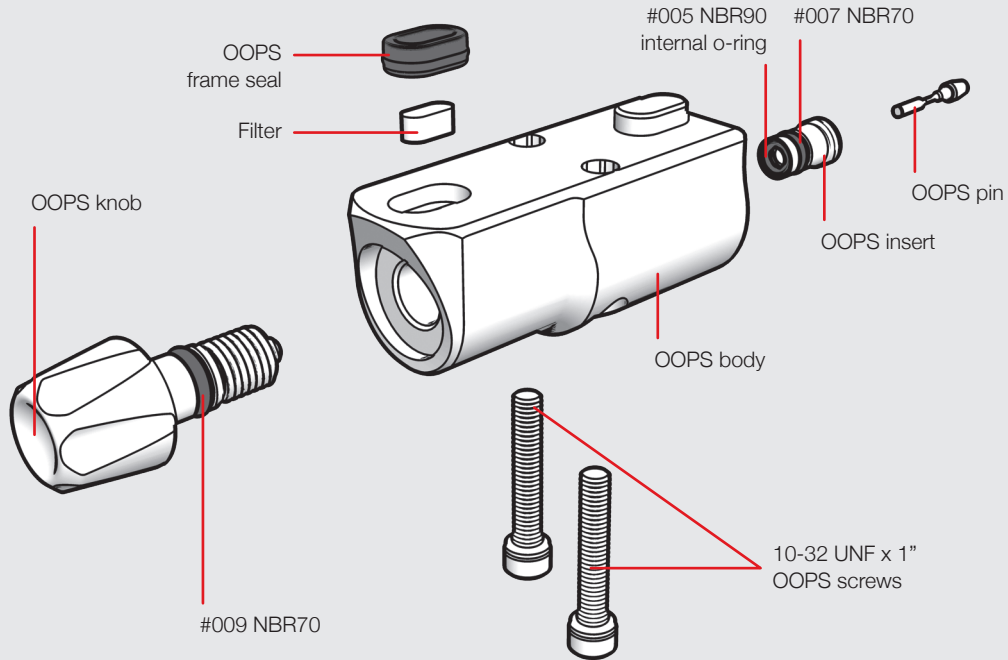

# TECHNICAL INFORMATION

## TRIGGER ASSEMBLY / CLAMPING FEED TUBE ASSEMBLY

FIG-1

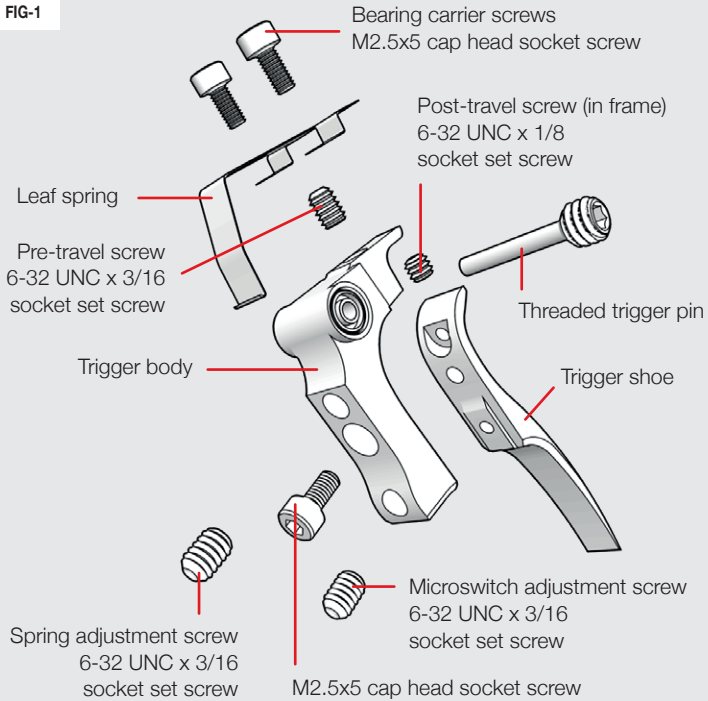
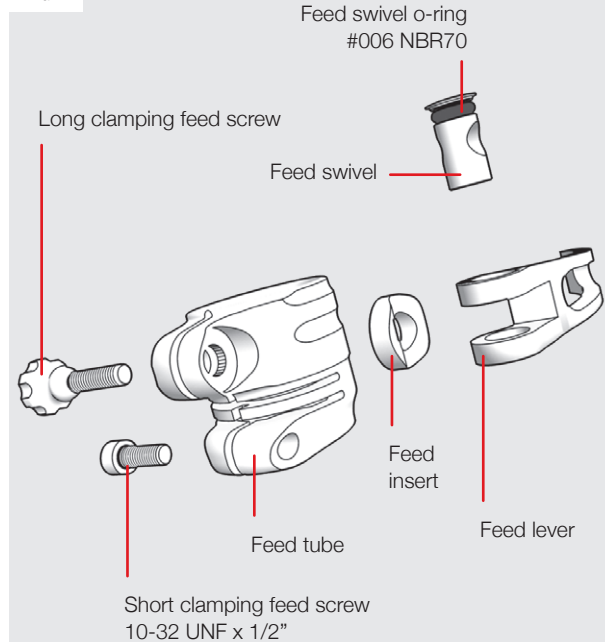

FIG-2



# TECHNICAL INFORMATION

## GTEK 160R CIRCUIT BOARD / OLED BOARD

**FIG-1 GTEK 160R circuit board**

- A** Solenoid valve connector.
- B** BS connector.
- C** Microswitch connector.
- D** Tournament lock button.
- E** LED.
- F** Select button.
- G** OLED board connector.
- H** OLED board.

**1** **IMPORTANT!** If you have removed your OLED board from the main circuit board, be careful when inserting the pins into the connector to avoid damage to the pins and/or the boards.

**FIG-1**

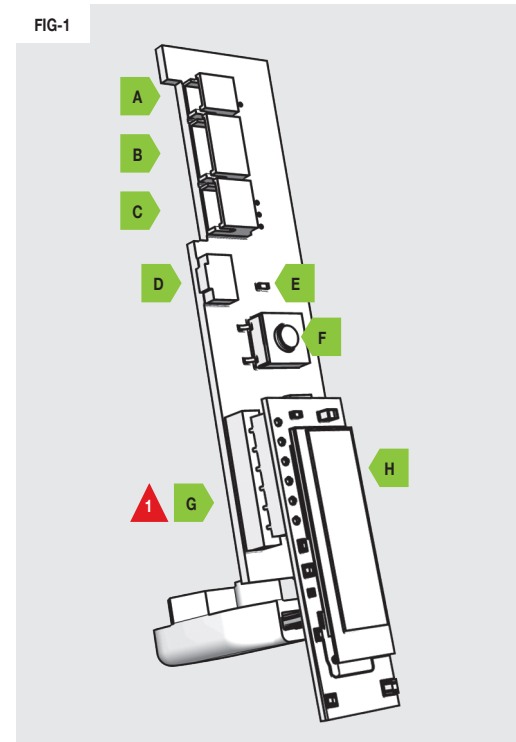
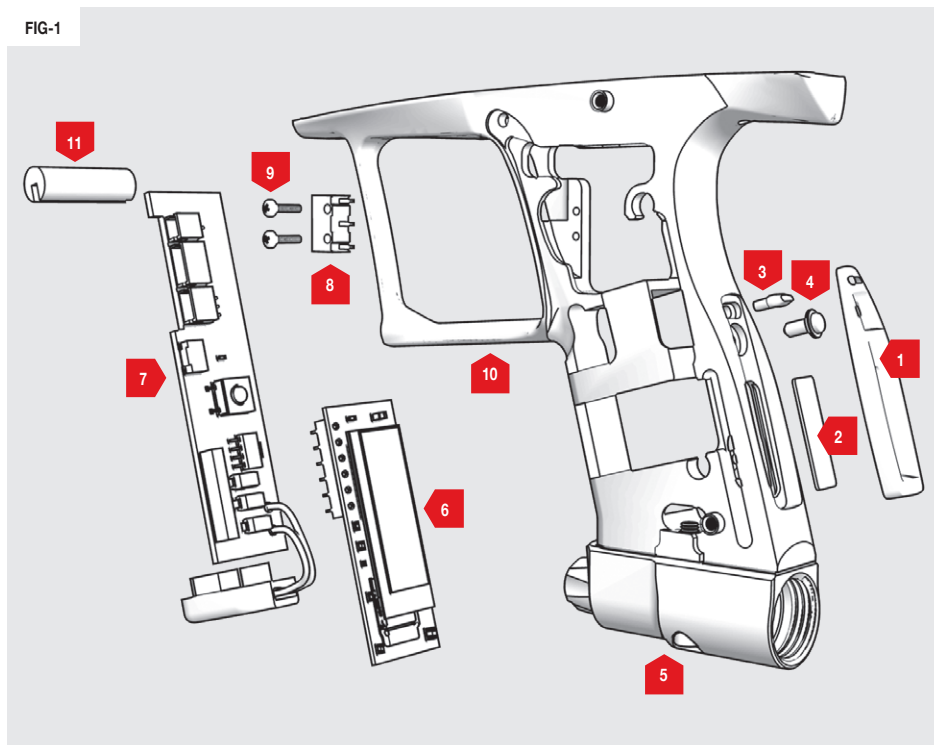

FIG-1

- 1** Navigation console
- 2** Protective lens
- 3** LED lightpipe
- 4** Select push button
- 5** OOPS assembly
- 6** GTEK 160R OLED board
- 7** GTEK 160R circuit board
- 8** Micro-switch retaining clip
- 9** Micro-switch retaining screws  
M2x8 pan cross head
- 10** GTEK 160R frame
- 11** Circuit board retaining clip

FIG-1





# TECHNICAL INFORMATION

## BREECH SENSOR (BS) ASSEMBLY

**FIG-1**

- A** Breech cover screw  
6-32UNC x 5/16  
countersunk socket screws
- B** Breech sensor cover
- C** Breech sensor
- D** Rubber detent

The elements within this diagram apply to both sides of the marker.

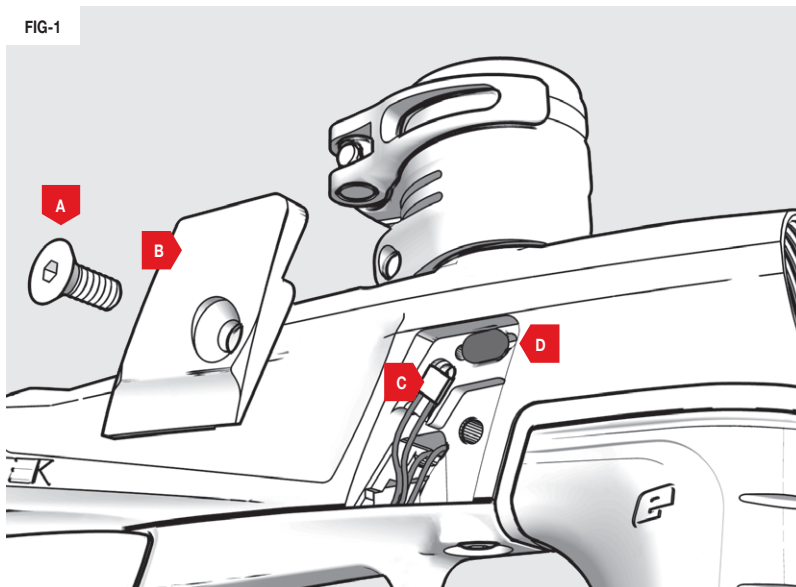
**FIG-1**

**A**

Air system: **07,13,26,27**  
AT pipe: **04,07,29,32**

**B**

Barrel: **07,13,23,31**  
Barrel blocking device: **07,13,31**  
Battery: **04,09,14,23,24,25,26,29**  
BLUE: **20,21**  
Bolt: **29,33**  
Breech sensor: **08,09,17,21,25,26,39**  
BS OFF ROF: **09,17**  
BS ON ROF: **17**

**C**

Circuit board: **04,30,37,38**  
Clamping feed neck: **07,13**

**D**

DEBOUNCE: **18,26**  
Detent: **27,29,39**  
Display: **08,16,19,20,26,27,30**  
DWELL: **18,27**

**F**

Factory settings: **22**  
Fault: **04,09,24,25,26,27**  
Feed neck: **07,13,23**  
Feed neck lever: **07,13**  
Firing: **08**  
FLASHING BLUE: **21**  
Frame: **23,25,29,31,35,36,38**

**G**

GREEN: **20,21**

**I**

Installing: **07,23**

**K**

KICK IN: **18**

**L**

LED: **04,08,20,21,30,37,38**  
LIGHT BLUE: **20,21**  
Loader: **07,13,31**

**M**

Maintenance videos: **15**  
Marker body: **29**  
Microswitch: **27**

**N**

Navigation console: **29,38**

**O**

OLED: **04,08,16,37**  
On/Off Purge System: **07,13**  
OOPS: **04,07,13,25,29,35,38**  
O-ring: **24,29,32,35,36**

**P**

Pre-travel screw: **36**  
PURPLE: **20,21**

**Q**

Quick-release bonnet: **29,33**

**R**

RED: **20,21**  
Regulator: **02,03,04,07,22,24,26,27,29,32**  
Reset: **04,19,21,22,23**  
RESTART: **18**

**S**

Select button: **08,20,37**  
Setting up: **06,07**  
Set-up mode: **04,16,20,21**  
Shot counter: **09,19**  
SL4: **04,29,32**  
SLEEP: **19**  
Solenoid: **04,18,24,29,34,37**  
Storage: **02,14**  
Switching On: **08**

**T**

Tournament lock: **09,20,21,30**  
Trigger: **08,09,11,18,20,21,25,26,27,36**

**V**

Velocity: **03,10,25,26**

**W**

WARNING: **03,07,08,09,10,11,13,14,23,30,31**  
WARRANTY: **41**

**Z**

ZERO: **19**

**SUPPORT**

As an Eclipse customer you will have access to our worldwide technical support network that will help you with any technical problems from localised service centres to on-site\* tech support.

**WARRANTY**

Our exceptional 12 month\* manufacturers warranty backed by our online warranty system offers peace of mind and ensures your claim will be repaired or replaced in a snap!

**QUALITY**

All Eclipse products undergo meticulous checks by experienced specialists who care about the product that arrives at your door. Stringent quality control and the use of precision materials equals a quality product.

**STANDARD**

Your Eclipse marker is awesome and requires no aftermarket parts, however, for genuine Eclipse accessories that compliment your playing preference or individual style consult your local Eclipse Dealer for upgrade options.

For more information about our Planet Eclipse Approved Tech Centres, visit our servicing page online:

[PLANETECLIPSE.COM/SITE/SERVICE-CENTRES](http://PLANETECLIPSE.COM/SITE/SERVICE-CENTRES)

\* Conditions apply, see online policies for full details at [planeteclipse.com](http://planeteclipse.com)





# YOUR WARRANTY REGISTRATION CARD.

Planet Eclipse offers a 12 month limited warranty period\* on the Eclipse® electro-pneumatic marker. The Eclipse® electro-pneumatic marker is warranted to be free from all manufacturing and production defects for a period of 12 months from the time of original purchase\*\*. Warranty cover is dependent on successful completion, and receipt by Planet Eclipse Limited, of warranty registration and proof of purchase, either in electronic form on [www.planeteclipse.com](http://www.planeteclipse.com) or vial email using the warranty card included in every Eclipse® electro-pneumatic marker manual. Warranty exemptions include, but are not limited to, accidental damage, wear and tear, unreasonable force, surface finish and perishable components such as o-rings, valves, screws, solenoids and break beam sensor units (at our discretion). By completing and returning this warranty card you agree to our privacy policy\*\*\*.

I verify that I am at least 18 years of age and I have read the manual supplied with my Eclipse® electro-pneumatic marker and I understand the safety cautions and warnings that it contains. (Contact your dealer or Planet Eclipse Limited directly if you need a replacement set of instructions.

Full name:	Price (e.g. \$500.00):
Address:	Colour:
	Where did you hear about your Eclipse marker?
	Magazines <input type="checkbox"/> Internet <input type="checkbox"/> Friends <input type="checkbox"/> DVD/Video <input type="checkbox"/>
	Other (please specify):
City:	Why buy Eclipse?
Postal/Zip Code:	<p style="text-align: center;"><b>ATTACH SERIAL HERE!</b></p> <p style="text-align: center;">Warranty card <b>MUST</b> be completed in full to be valid and bear the Eclipse marker serial sticker that came with your Eclipse marker.</p>
State:	
Country:	
Contact No:	
Email:	
Date of purchase (DD/MM/YY):	
Purchased from:	

Please complete and return this form with proof of purchase, within 14 days so that we may validate your 12 month limited warranty on your Eclipse® manufactured product. Please return to the address on the reverse of this form.

\* For full terms and conditions that apply to the limited warranty visit [www.planeteclipse.com](http://www.planeteclipse.com)

\*\* Limited warranty is valid for 12 months from the proof of purchase date, or 12 months from the date of manufacture if no proof of purchase is provided.

\*\*\* Full details of the Planet Eclipse privacy policy can be found at [www.planeteclipse.com](http://www.planeteclipse.com)



**GET MORE - PLANETECLIPSE.COM**

LICK.  
STICK.  
SEND.

*PLANET ECLIPSE  
130 FRANKLIN STREET  
BUILDING L4 & L5  
WARREN  
RHODE ISLAND  
02885  
U.S.A.*



REGISTER ONLINE

—



GET MORE  
PLANETECLIPSE.COM



802.060.A-000

**THIS PRODUCT IS COVERED BY AND/OR LICENSED UNDER ONE OR MORE OF THE FOLLOWING PATENTS:**

**G.B. PATENTS:**

2,342,710; 2,345,953; 2,352,022; 2,391,292; 2,391,063;

**U.S. PATENTS:**

7,836,873; 7,603,995; 7,073,284; 8,104,463; 7,509,953; 7,921,839; 7,089,697; 7,866,307; 8,082,912; 7,076,906; 7,607,424; 7,980,238; 8,960,175; 8,528,877; 8,201,547; 8,397,706; 8,210,160; 7,073,284; 6,311,682; 6,748,938; 6,860,259; 6,941,693; 6,973,748; 5,881,707; 5,967,133; 6,035,843; 6,474,326; 6,637,421; 6,644,295; 6,810,871; 6,901,923; 7,121,272; 7,100,593; 7,610,908; 7,603,997; 7,946,285; 6,349,711; 7,044,119; 7,185,646; 7,461,646; 7,556,032; 7,591,262; 7,617,819; 7,617,820; 7,640,925; 7,640,926; 7,866,308;

**APPLICATION NUMBERS:**

12/256,832; 12/613,958; 12/493,777; 11/654,721; 11/747,107; 12/503,504; 11/781,821; 60/832,548; 11/965,886; 10/280,115

Additional U.S. and International Patents may be pending.

**USA**

130 Franklin Street  
Building L4 & L5  
Warren, RI, 02885, USA  
Call: +1 401 247 9061  
info.usa@planeteclipse.com

**UK**

Unit 14 Premier Park, Acheson Way  
Trafford Park Road, Trafford Park  
Manchester, M17 1GA, England  
Call: +44(0) 161 872 5572  
info.europe@planeteclipse.com

© 2016 Copyright Planet Eclipse Ltd. Eclipse, Planet Eclipse, the E Logo Device, GEO, EGO, GTEK 160R, GTEK, ETEK, ETHA and EMC are all either design trademarks, registered trademarks or trademarks of Planet Eclipse Ltd. All other trademarks are property of their respective owners.

MAN0021-GTEK160R-EN-Manual-V2